

Motor Performance Characteristics and Application Guidelines

Introduction

This letter will cover motor performance characteristics including torque, voltage, unbalanced currents, and hazardous duty motors and the use of 3600 RPM "TS" motors on belt drive applications. Motor performance changes where fans are concerned seem mysterious. This engineering letter will reveal what is behind the mystery.

For further information, please refer to FE-800: Integral AC Motor Selection and Application Guide for Fans; FE-1100: Single-Phase AC Induction Squirrel Cage Motors; and FE-3000: Motor Classifications.

Understanding Torque

In the process of applying motors to fans, we are misled into believing that we are applying horsepower. The real driving force is not horsepower; it is TORQUE.

Torque is the twisting force supplied by a motor to a fan. In fan applications, the motor must supply a substantial amount of torque before it will even start to turn. In the English system, the standard units of torque are pound inch (lb-in) or pound feet (lb-ft).

Torque and horsepower are related to each other by a basic formula that states:

$$\text{Horsepower} = (\text{Torque} \times \text{Speed}) / \text{Constant}$$

The value of the constant changes depending upon the units that are used for torque. The most frequently used combinations are as follows:

$$\text{HP} = (T \times S) / 5252$$

where T = Torque in lb-ft and S = speed in rpm

$$\text{HP} = (T \times S) / 63025$$

where T = Torque in lb-in and S = speed in rpm

In order to save time, graphs and tables are frequently used to show values of torque, speed, and horsepower.

When adjustable speed drives, such as DC SCR units, magnetic couplings, or variable frequency drives are utilized, a determination of load type must be made. The most common type of torque is "constant torque" load. The relationship of torque and horsepower to speed for a constant torque load is shown in Figure 1. Another type is "variable torque" load. This is the type that is found in fans and blowers. For a variable torque load, the torque required at low speed is very low but the torque required at high speed is very high. Mathematically, the torque requirement is a function of the speed squared and the horsepower is a function of the speed cubed. The relationship of torque and horsepower to speed on "variable torque" loads are shown in Figure 2.

Figure 1. Constant Torque – Speed-Torque Relationship

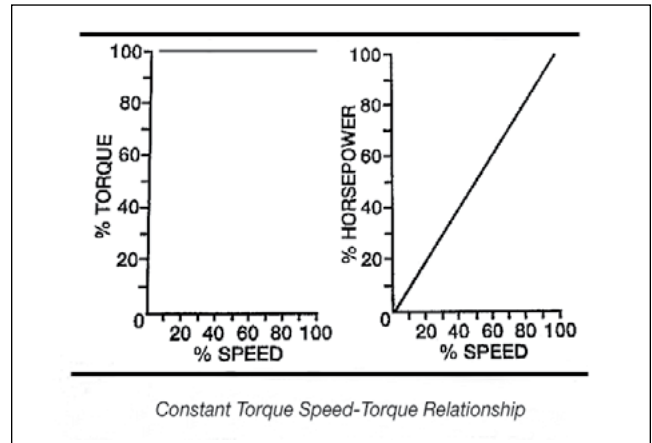
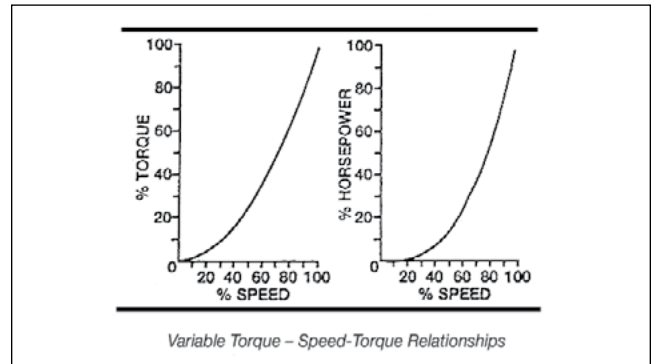

Figure 2. Variable Torque – Speed-Torque Relationship



In the case of "constant torque" loads, the drive must be sized to handle:

1. The torque required to breakaway the load,
2. The torque required to run the load,
3. The output speed required to operate the machine at the maximum required speed.

Please note that only after the load has been started and adequate torque is available to run it, does speed become a factor.

Only after these three items have been determined is it possible to calculate the required horsepower for the application.

The key to drive sizing on "variable torque" loads is strictly related to providing adequate torque and horsepower at the maximum speed that will be required. Maximum must be emphasized since a 9% increase in speed over the normal maximum will produce a 30% increase in the horsepower requirement.

It is impossible to speculate on the number of motors that have been burnt out because people have unknowingly changed pulley ratios to obtain "more output" from their fans and blowers.

Table 1 illustrates the very dramatic changes in horsepower requirements for relatively small changes in speeds that occur with "variable torque" loads.

Table 1.

% SPEED CHANGE	% TORQUE CHANGE	% OF ORIGINAL HP	% HP CHANGE
-20	-36	51	-49
-15	-28	61	-39
-10	-19	73	-27
-5	-10	86	-14
0	0	100	0
+5	+10	116	+16
+10	+21	133	+33
+15	+32	152	+52
+20	+44	173	+73

Most variable speed drives are inherently capable of handling "variable torque" loads provided that they are adequately sized to handle the horsepower requirement at the maximum speed.

High Inertia Loads

Motor driven equipment that fall into this class are fans, flywheels, hammer mills, and some types of machine tools. A load is generally considered to be "high inertia" when the reflected inertia at the motor shaft is greater than five times the motor rotor inertia.

High inertial loading has to be considered only during acceleration and deceleration. For example, if a standard motor is applied to a large high inertia fan, there is the possibility that the motor could be damaged or fail completely on its first attempt to start. This failure could occur even though the motor might have more than adequate torque and horsepower capability to drive the load after it reaches the required running speed.

A good example of high inertia that most of us are familiar with is a jet plane taking off. In this case, the maximum output of the engines is required to accelerate the weight of the plane and its contents. Only when it reaches take-off speed and is nearly ready to leave the ground do the engines start doing useful work for moving the plane to the final destination.

Similarly, when the plane lands, the reversed thrust of the engines and brakes are used to slow down and stop the inertia of the plane.

In the Motor, Fan and Drive industry, the inertia of a rotating body is referred to as the WR^2 or WK^2 . In the English system, "W" is the weight in pounds and "R" or "K" is the radius of gyration in feet. It is usually easy to obtain the weight of the body, but determining the radius of gyration can be a little more difficult.

Motor and fan manufacturers can be asked to supply the maximum WR^2 limits for any specific requirement. It is normally noted in their catalogs. (Please note WK^2 and WR^2 are used interchangeably and they are the same.) Typical values and starting times can be found in Fan Engineering Data Letter 1800.

When loads having high inertias are encountered, several approaches can be used. Some possibilities are:

1. Oversize the motor
2. Use reduced voltage starting
3. Use special motor winding design
4. Use special slip couplings between the motor and load
5. Inverter drives with long starting times.

The Mystery of Fans

A family of motor applications that tend to confuse people, who are not regularly involved with them, is that of variable torque loads. These loads represent a high percentage of motor requirements so it is desirable to have a little extra knowledge of the mysterious aspects of these loads. Variable speed loads are fans, blowers, and centrifugal pumps.

There are two mysterious characteristics that these loads have. The first is the way they act when speed is changed. The rules that cover these characteristics are called the "affinity laws". For example, we can discuss a fan. What we find is that as the amount of air increases, the torque required to rotate the fan goes up as a squared function of speed ($Speed^2$). Thus, increasing the speed causes the torque required by the fan to go up, not directly with speed, but in proportion to the change of speed squared. For example, if we change the speed from 1160 to 1760 RPM the torque required will increase by the ratio of $(1760/1160)^2$. This would mean that the torque required would go up 2.3 times to 230% of the original value. Also, since horsepower (HP) is based on speed times torque, and the speed has increased by 52%, the new value of HP would be 2.30×1.52 or almost 350% of the HP required at the original speed.

The dramatic increases in the horsepower needed to drive these loads when speed increases is a little difficult to understand but it is very important. It is important because small decreases can result in great energy savings. For example, decreasing the speed of a variable torque load by only 20% will result in a driving energy reduction of nearly 50%. This obviously has big importance when conservation is considered. It also accounts for the tremendous market that exists for variable frequency drives operating Variable Air Volume (VAV) systems used in heating, ventilating, air conditioning, and variable speed pumping used in similar systems.

The second puzzling thing that occurs with variable torque loads is that the motor load actually decreases as the output or input to the fan is blocked off or restricted. There was once a reported call from a motor user who had burnt out a motor driving a blower on a heating system. The motor was driving a blower that drew air through a filter and fed it to a ducted distribution system. When they were asked if there had been any changes in the system, he stated, "Well, we extended the ducts into another room and cut the end off to let the air flow, but that would have made it easier for the motor not more difficult." When he was told the opposite was true, he could not believe it. It defies good judgement to think that adding a restriction to the output of the blower would decrease the motor load. If you don't believe it, here is a simple test. Take a vacuum cleaner and listen to it carefully. You will notice that the pitch of the motor goes up when the suction is closed. What this means is that the load is being reduced on the motor and it speeds up. If you still do not believe,

you can do the same test but with an ammeter on the motor. What you will find is that the amps drop as the suction level is increased.

As another example, think of fans applied to a dust collection system. The maximum load occurs when everything is clean. As the filter bags get loaded with dust, the back pressure increases and the load on the blower and motor is reduced.

The amount of overloading or underloading that occurs as a result of changes in the "back pressure" on the blower will depend on the specific design of the wheel used. Some blowers, such as, the Backward Incline are designed to be non-overloading. But in some cases, the worst case occurs at the open discharge condition.

Electric Motors and Voltage

The effect of low voltage on electric motors is pretty widely known and understood, but the effect of high voltage on motors is frequently misunderstood.

Effects of Low Voltage

When electric motors are subjected to voltages below the nameplate rating, some of the characteristics will change slightly and others will change more dramatically. A basic point is that, in order to drive a fixed mechanical load connected to a shaft, a motor must draw a fixed amount of power from the power line. The amount of power the motor draws is roughly related to the voltage times current (amps). Thus, when voltage gets low, the current must get higher to provide the same amount of power. The fact that the current gets higher is not alarming unless it exceeds the nameplate current rating of the motor. When amps go above the nameplate rating, it is safe to assume that the buildup of heat within the motor will become damaging if it is left unchecked. If a motor is lightly loaded and the voltage drops, the current will increase in roughly the same proportion that the voltage decreases.

For example, a 10% voltage decrease would cause a 10% amperage increase. This would not be damaging if the motor current stays below the nameplate value. However, if a motor is heavily loaded and a voltage reduction occurs, the current would go up from a fairly high value to a new value that might be in excess of the full load rated amps. This could be damaging. It can be safely said that low voltage in itself is not a problem unless the motor amperage is pushed beyond the nameplate rating.

Aside from the possibility of over-temperature and shortened life created by low voltage, some other important items need to be understood. The first is that the starting torque, pull-up torque, and pull-down torque of induction motors all change based on the applied voltage squared. Thus, a 10% reduction in nameplate voltage (100% to 90%, 230 volts to 207 volts) would reduce the starting torque, pull-up torque, and pull-out torque by a factor of $.9 \times .9$. The resulting values would be 81% of the full voltage values. At 80% voltage, the result would be $.8 \times .8$ or a value of 64% of the full voltage value.

In this case, it is easy to see why it would be difficult to start "hard-to-start" loads if the voltage happens to be low. Similarly, the motor's pull-out torque would be much lower than it would under normal voltage conditions.

To summarize the situation, low voltage can cause high currents and overheating that will subsequently shorten motor life. Low voltage can also reduce the motor's ability to get started and its values of pull-up and pull-out torque. On lightly loaded motors with easy-to-start loads, reducing the voltage will not have any appreciable effect except that it might help reduce the light load losses and improve the efficiency under this condition.

Effects of High Voltage

One thing that people assume is, since low voltage increases the amperage draw on motors, then by this same reasoning, high voltage would tend to reduce amperage draw and heating of the motor. This is not the case. High voltage on a motor tends to push the magnetic portion of the motor into saturation. This causes the motor to draw excessive current in an effort to magnetize the iron beyond the point to which it can easily be magnetized. This generally means that the motors will tolerate a certain change in voltage above the design voltage but extremes above the designed voltage will cause the amperage to go up with a corresponding increase in heating and a shortening of motor life. For example, older motors were rated at 220/440 and had a tolerance band of $\pm 10\%$. Thus, the voltage range that they can tolerate on the high voltage connections would be 396 to 484. Even though this is the so-called tolerance band, the best performance would occur at the rated voltage. The extreme ends, either high or low, would be putting unnecessary stress on the motor.

Generally speaking, these tolerance bands are in existence not to set a standard that can be used all the time, but rather to set a range that can be used to accommodate the normal hour-to-hour swings in plant voltage. Operation on a continuous basis at either the high extreme or the low extreme will shorten the life of the motor.

Overall, it is definitely in the equipment's best interest to have the utility company change the taps on incoming transformers to optimize the voltage on the plant floor to something that is very close to the equipment ratings. In older plants, some compromises may have to be made because of the differences in the standards on old motors (220/440) and the newer "T" frame standards (230/460), but a voltage in the middle of these two voltages, something like 225 or 450 volts, will generally result in the best overall performance. High voltage will always tend to reduce power factor and increase the losses in the system, which results in higher operating costs for the equipment and the system.

The graph shown in Figure 3 is widely used to illustrate the general effects of high and low voltage on the performance of "T" frame motors. It is acceptable to use the graph to show "general" effects, but bear in mind that it represents only a single motor and there is a great deal of variation from one motor design to the next.

For example, the lowest point on the full load amp line does not always occur at 2% above rated voltage. On some motors, it might occur at a point below rated voltage. Also, the rise in full load amps above rated voltage tends to be steeper for some motor designs than others.

Some general guidelines might be useful.

1. Small motors tend to be more sensitive to over-voltage and saturation than large motors.

Figure 3. Effects of High and Low Voltage

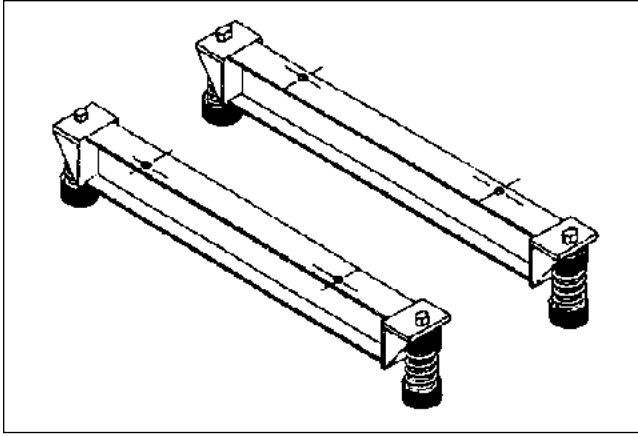

2. Single-phase motors tend to be more sensitive to over-voltage than three-phase motors.
3. U-frame motors are less sensitive to over-voltage than "T" frames.
4. Premium efficiency motors are less sensitive to over-voltage than standard efficiency.
5. Two pole and four pole motors tend to be less sensitive to high voltage than six pole and eight pole designs.
6. Over-voltage can drive up amperage and temperature even on lightly loaded motors. Thus, motor life can be shortened by high voltage.
7. Full load efficiency drops with either high or low voltage.
8. Power factor improves with lower voltage and drops sharply with high voltage.
9. Inrush current goes up with higher voltage.

Unbalanced Currents

Motor users and installers get concerned when they detect unbalanced phase currents on a 3-phase motor. The question is frequently asked: "Is there something wrong with the motor?"

History

In the old days, the only sources of unbalanced phase currents was usually a problem in the motor, such as an unbalanced number of turns in the windings, an uneven air gap, or unbalanced phase voltages. Winding or air gap problems are definitely motor related. On the other hand unbalanced phase voltages are a power system problem. Unbalanced voltages will generally produce unbalanced currents that are many times greater than the percentage of voltage unbalance. The ratio used is close to 8:1. In other words, an unbalanced voltage of 1% could create unbalanced phase currents of as much as 8%.

A very unscientific way of looking at the problem is as follows: Suppose a motor has a nameplate full load current of 10 amps. At full load, the amps on each leg of the 3 phases added together would be 10+10+10 or 30. However, if the load is the same but the phase currents are unbalanced, the total of the 3 legs added together will always be more than the total of the balanced currents. In this case, the currents might be 10.5, 11.3, and 12.1 for a total of 33.9. This is a very unscientific way of looking at it, but it is accurate in describing the effect. What this means is that high current on one leg does not mean that the other two legs will be reduced by an equal amount. It can be said that unbalanced currents always result in higher operating temperature, shortened motor life, and efficiency reduction.

The next question is "What creates unbalanced currents?" In past years, if the motor was not the problem, the source of unbalanced currents was unbalanced phase voltages. When measuring line to line voltages from phases A to B, B to C, and C to A, detectable differences in the voltages would show up. The voltage differences would account for the unbalanced currents.

In today's world there are other problems that are frequently not detectable with simple voltage tests. One problem of growing concern is voltage distortion caused by harmonics in the power system currents. This can happen if there are loads in the general area that draw non-linear (harmonic rich) currents from the power system. They can create voltage distortion in the normal voltage sine-wave that, in turn, can cause unbalanced currents in motors even when phase voltage differences are not detectable with a voltmeter. For example, if you were to detect unbalanced motor currents and took measurements with a digital voltmeter on the three phases, they might be very close to one another. The natural tendency under these conditions would be to blame the motor for the problem. When this happens, it is necessary to go a step further to identify or dismiss the motor as the cause of the problem. The test is to rotate all 3 phases. If the power phases are labeled A, B, and C and the motor leads to them are labeled 1,2, and 3, motor lead #1 might be reconnected to power supply lead B; motor lead #2 would be reconnected to power supply lead C; motor lead #3 would be reconnected to power supply lead A. Moving all three legs will keep the motor rotating in the same direction. The currents are recorded on each power line leg before and after the connections are changed. If the high current leg stays with the power line phase (for example, B), then the problem is a power supply problem rather than a motor problem. If however, it moves with the motor leg, then it is a motor problem. Therefore, use this test to pinpoint the problem as either power supply or motor.

How Much Unbalance Can Be Tolerated?

In general, this depends on the conditions that are found. If the motor is driving the load and the highest amperage of the three legs is below the nameplate Full Load rating, then generally it is safe to operate. If the high leg is above the nameplate rating, but within the normal service factor amps (for a motor with a service factor, normal is 1.15), then it is probably still safe to operate the motor. Also, it is not unusual to find currents more unbalanced at no load than they will be under load, so the loaded amps should be used. Finally, in general, if the high leg is not more than 10% above the average of the three legs, (see the example below), it is probably safe to operate the motor.

Example:

Motor Nameplate FLA = 10.0 Service Factor = 1.15

Phase	Loaded Amps
A	10.6
B	9.8
C	10.2

Determine the average: $10.6+9.8+10.2 / 3 = 10.2$ amps

Determine the % difference: $\text{highest phase} - \text{average} / \text{average} \times 100$

$$(10.6-10.2)/10.2 \times 100 = 3.9\%$$

The following table shows some of the sources of unbalanced voltages and currents, along with possible remedies.

Table 2.

PROBLEM	SOLUTION
Blown fuse on a power factor correction capacitor bank	Search, find, and replace blown fuse
Uneven single phase loading of the 3-phase system	Locate single phase loads and distribute them more evenly on the 3-phase circuit
Utility unbalanced voltages	If the incoming voltages are substantially unbalanced, especially at lightly loaded or no load periods, contact the utility company and ask them to correct problem
Harmonic distortion	Locate the sources of the harmonics and use harmonic filters to control or reduce harmonics. Install line reactors on existing and new variable frequency controls.

Primer on Hazardous Duty Motors

Hazardous locations are operating environments in which explosive or ignitable vapors or dust is present, or likely to be present. Special motors are required to ensure that any internal fault in the motor will not ignite the surrounding vapor or dust. Requirements for electrical installations in hazardous locations are covered in Articles 500,501,502 503, 510, 511, 513, 514, 515, and 516 of the National Electrical Code.

The term "explosion proof" is often erroneously thought to apply to any hazardous-location motor. Explosion proof motors, however, are only those approved for Class I locations – that is, where potentially explosive gases or vapors are present. A Class I unit is constructed to contain an explosion within itself without rupturing. After the initial pressure buildup on ignition, the hot gas is forced to cool by passing through long, tight passageways (flame paths) before escaping the motor. The temperature of the gas escaping the motor will then be below the minimum ignition temperature (MIT) of the gases of vapors in the atmosphere surrounding the motor to prevent a secondary explosion.

Meaning of Motor "Class" Designations

Every motor approved for hazardous locations carries an Underwriters Laboratories' nameplate for hazardous locations. This nameplate identifies the motor as having been designed for operation in Class I or Class II locations. Some motors may be approved for both Class I and II locations.

Basically, the Class identifies the physical characteristics of the hazardous materials present at the location where the motor will be used. Class I covers gases, vapors, or liquids that are explosive or pose a threat as ignitable mixtures. A familiar example of a Class I material is gasoline. It is explosive as a vapor and ignitable as a liquid. Some of the most common Class I substances are listed in Table 3.

Class II covers dust – specifically, dust in amounts sufficient to create explosive mixtures and dusts that are electrically conductive. A prime example of a hazardous dust is wheat flour. As a compact mass, flour burns or smolders; but when it is finely distributed in air, it is highly explosive. Also included in Class II are electrically conductive metallic and nonmetallic dusts, such as powdered aluminum and magnesium dusts that can burn violently even when not suspended in air; but when airborne, they are explosive. Some common Class II substances are listed in Table 4.

Class III locations do not normally require hazardous-location motors. Specifying a hazardous-location motor

Table 3. Class I Substances and Atmospheres

SUBSTANCE OR ATMOSPHERE	GROUP	MINIMUM IGNITION TEMP. (°F)
acetylene	A	581
Butadiene	B	788
Ethylene oxide	B	1058
Hydrogen	B	932
cyclopropane	C	928
ethylene	C	842
isoprene	C	743
acetone	D	869
gasoline	D	536
propane	D	851

Table 4. Class II Substances

SUBSTANCE	GROUP	DESCRIPTION
Metallic Dusts	E	Dusts of aluminum, magnesium, and their commercial alloys
Electrically conducting non-metallic dust	F	Coal dust, pulverized coal, pulverized coke, pulverized charcoal, carbon black
Electrically non-conducting dusts	G	Grain dusts, pulverized sugar, dried powdered potato, pulverized cocoa, wood flour, oilmeal from beans and seeds

for Class III locations is a common error. Section 503-6 of the NEC permits a totally enclosed fan-cooled or nonventilated motor to be used in Class III locations. A totally enclosed motor can be purchased at a lower cost than a motor approved for hazardous locations. NEC Section 503-6 also allows the use of an open drip-proof motor in Class III locations, if the inspection authority is satisfied that proper housekeeping will be maintained. Class III locations are those where easily ignitable fibers and "flyings" are likely to be present. Such substances are commonly encountered in the textile, woodworking, and plastics industries. Class III materials are not normally airborne, because they are fairly heavy and settle rapidly. They are, however, quite flammable and, therefore, create a potentially hazardous condition when near electrical equipment. Common Class III substances are listed in Table 5.

Table 5. Class III Substances - no groups assigned

Rayon	Cotton	Sawdust
Hemp	Jute	Cocoa fiber
Oakum	Excelsior	

Meaning of "Group" Designations

Within Class I and Class II, group designations are assigned to various combustible substances on the basis of their behavior after ignition. Group designations A-G are arranged in descending order according to the stringency of motor design requirements. Group A would require the longest flame paths and tightest fits. Groups A-D fall within Class I and Groups E, F and G fall within Class II. Class III materials are not broken down by group.

Gasoline and acetylene provide an illustration of the group concept. Both are Class I substances. Acetylene is designated as a Group A substance, gasoline falls within Group D. MIT of automotive gasoline is 536°F, slightly above the 581°F MIT of acetylene. An acetylene explosion, however, is more intense than a gasoline explosion, so acetylene is grouped well above gasoline.

It is a common misconception that Class I transcends Class II and that a Class I motor will automatically satisfy any Class II requirement. But a Class I motor is designed primarily to confine the effects of an internal motor explosion. Design is based on the assumption

that, over a period of time, normal heating and cooling will cause the motor to breathe the surrounding atmosphere, and the atmosphere within the motor will eventually become the same as that of the operating environment. A subsequent internal fault can, therefore, cause an explosion within the motor.

A Class II motor, however, is designed to maintain the motor's surface temperature at a level such that Class II materials in the motor operating environment contain both Class I and Class II substances. A dual rated Class I/Class II motor must be specified.

Another common misconception is that because the Classes and Groups exist, there should be suitable products (motors or other equipment) to operate in the defined environment. As it turns out, Classes and Groups are used for all types of equipment including enclosures, light fixtures, heating elements, operator devices, etc. But just because there is a definition it does not mean that a matching product is available. In the case of motors this is especially true for Class I, Groups A and B. Apparently, the market for motors to operate in these environments is so limited, and the designs so difficult, that most manufacturers do not make them.

The most common hazardous location motors are made for Class I, Group D and Class II, Groups F and G. Several manufacturers can build motors for Groups C and E but they are normally made on a special order basis.

Meaning of "Division" Designations

Hazardous locations are further broken down into Divisions 1 and 2. The distinctions are defined in detail in Article 500 of the NEC. Simply stated, a Division 1 location is one in which ignitable substances are likely to be present continuously or intermittently in the course of normal operations. In a Division 2 location, ignitable materials are handled or stored in a manner that allows the combustible substance to escape in the event of spill, accident, or equipment failure.

Although standard non-explosion proof motors are permitted in areas classified as Division II, it is Twin City Fan Companies' policy to provide explosion proof motors for Division II locations. If the engineer or owner specifically states (in writing) that a standard (non-explosion proof) motor is acceptable, then a standard TEFC motor will be provided. This motor will not be labeled for Division II.

Whenever a Division II motor is specified and the motor enclosure (TEFC or TEXP) is not specified, ascertain from the engineer or owner which type of motor is acceptable. If they cannot provide the information, an explosion proof motor will be quoted.

Hazardous Location Motor T-Codes

All motors manufactured after February, 1975 carry a T-code designation. See Table 6 below. The T-code identifies the maximum absolute motor surface temperature that will be developed under all conditions of operation, including overload up to and including motor

burnout. The T-code designation of the motor must be correlated with the Minimum Ignition Temperature (MIT) of the substances in the motor's operating environment. The presence of acetone or gasoline, for example, will affect motor selection. Acetone and gasoline are both Class I, Group D materials. Acetone has an MIT of 869oF. This indicates that a motor with a T1 rating (842oF) would be acceptable for operation in an acetone environment.

Table 6. T-Codes and Their Associated Temperatures

T #	MAX. MOTOR SURFACE TEMPERATURE (°F)	T #	MAX. MOTOR SURFACE TEMPERATURE (°F)
T1	842	T3A	356
T2	572	T3B	329
T2A	536	T3C	320
T2B	500	T4	275
T2C	446	T4A	248
T2D	419	T5	212
T3	392	T6	185

Gasoline, however has a MIT of 536°F. For operation in an environment containing gasoline, no less than a T2A motor, designed to develop a surface temperature no greater than 536oF should be specified. Although T-codes and ignition temperatures are conservatively assigned and based on "worst case" testing procedures, an extra margin of safety should be provided by specifying a T2B or higher T-rated motor, which is designed to develop a maximum surface temperature of 500°F.

Meeting some of the lower temperature T-code requirements necessitates the use of automatic overload devices (fractional horsepower motors) or normally closed (NC) winding thermostats in larger (integral horsepower) motors.

Winding thermostats are control devices with relatively low current capacity. They have to be connected to the motor's magnetic starter to cause it to interrupt power to the motor when the internal temperature gets too high. Failure to make the required "control circuit" connection will negate the motor nameplate T-code rating. This does not apply to smaller horsepower motors.

Use of 3600 RPM "TS" Motors on Belt Drive Applications

"TS" motors have short shafts. These motors are not designed for radial loads that would be imposed by belt applications. They have smaller bearings and the output shaft extensions are smaller in diameter.

When it is necessary to use these motors, the application must be sent to the motor manufacturer for approval or redesign. This may require a change from ball bearings to roller bearings, a higher strength shaft steel or a larger shaft. In addition, it is usually necessary to use larger diameter drives to reduce the belt pull and, therefore, the loading on the bearings.

Use of 3600 RPM "T" Motors on Direct Coupled Applications

On large motors with cylindrical roller bearings, do not use 3600 RPM "T" motors on direct coupled applications. The lack of sufficient radial load on the bearing can cause bearing failures.



AEROVENT | WWW.AEROVENT.COM

5959 Trenton Lane N | Minneapolis, MN 55442 | Phone: 763-551-7500 | Fax: 763-551-7501