



Belt Driven Plug Fans

IM-230
June 1997

General Installation, Operation and Maintenance Instructions For Aerovent Products

Aerovent plug fans are designed for continuous duty in air-moving systems, handling clean air where the fan becomes an integral part of another system.

As a general rule, these fans are designed to be installed in any position; however, reduced bearing life may result in some vertical applications, which require maximum static pressures and horsepower.

The mounting panel, which is an integral part of the assembly, permits easy installation to any well supported plenum.

Upon receipt of equipment, inspect the fan and its accessories for possible damage in shipment. Make certain the wheel rotates without binding. Never lift the plug fan by its motor, fan wheel or shaft. Lifting eyes are provided for this purpose.

If the unit is not to be put in operation for a period of time and is to be stored, the following precautions should be observed:

1. Select a clean, dry location to prevent rust.
2. For outside storage, protect against the elements by covering the entire fan.
3. Make certain bearings are filled with grease. (See General Installation and Maintenance Manual IM-100 for lubrication procedure.)
4. Keep motors dry and clean.
5. Periodically inspect unit to see if conditions are present which could cause damage.

V-Belt Drive

Normally these units are shipped with motor and drives in place, and it is only necessary to check for belt alignment and proper tensioning. In cases where these units are furnished less the motors and/or drives, the mounting procedure is as follows:

1. Mount the motor on the adjustable base and secure with the hardware provided. When located properly, the motor end bell should be in a line with the end of the motor base.
2. Remove the rust preventative compound on the end of the fan shaft with a suitable solvent and wipe the motor shaft clean.
3. Coat shaft with a light film of oil and mount sheaves onto the shafts. Do not force the sheaves onto the shafts as this may damage the fan and motor bearings. Do not apply any lubricant to the bushings, threaded components, or setscrews. Be sure to wipe off any excess lubricant in order to prevent the likelihood of any of the drive components from coming loose during operation.

4. Install the belts. Belts should be worked carefully over the grooves of each sheave until they are properly in place. Belts should never be forced on with a screwdriver or similar tool as this may break the cords in the belts. After the belts have been installed, adjust the sheaves so that both shafts are at right angles to the belts. Once proper alignment is assured, tighten sheaves in place.
5. Take up slack by adjusting the motor base adjustment screws. Proper belt tension is important. If belts are too tight, undue wear on fan and motor bearings will result. Insufficient tension shortens belt life and may cause vibration. Use drive manufacturer's recommendations for correct belt tension.
6. **IMPORTANT: BEFORE PUTTING THE UNIT INTO CONTINUOUS OPERATION, INSTALL BELT GUARD.**
7. After several days of operation, check belt tension and sheave alignment.

Bearings

Before the unit is put in operation, tighten bearing collar setscrews and bearing anchor bolts. Rotate shaft to check alignment.

All grease lubricated bearings are completely filled with grease prior to shipment from the factory. This prevents the condensation of moisture in the pillow block during shipment and before the unit is installed.

IMPORTANT: The bearings will discharge excess grease through the seals for a short period of time after start-up. Do not replace this initial discharge because leakage will cease after the excess grease has been purged from the bearings. Also, the purging of the excess grease will cause the bearings to heat up but the heat will dissipate after the purging.

Observation of the condition of the grease expelled from the bearing at the time of relubrication is the best guide as to whether the regreasing intervals and amount of grease added should be altered. When regreasing, use lubrication instructions for fan ball bearings as outlined in IM-100 which is included with the shipment. Avoid mixing different types of grease. Bearings should be flushed and refilled with fresh grease at approximately one-year intervals. **DO NOT OVER LUBRICATE.**

Maintenance

Regular and systematic inspection of all fan parts is the key to good fan maintenance. Frequency of inspection is determined by the severity of the application and local conditions. Once a maintenance schedule is established, it should be strictly followed. Regular fan maintenance should include the following:

1. Check fan wheel for any build-up of foreign material or excessive wear from abrasion. Both can cause vibration which creates a serious safety hazard. Any build-up of foreign material should be removed. If the wheel shows excessive wear, replace it immediately.

Cleaning of the wheel should be accomplished, if possible, without removing it from the shaft. If the plenum is furnished with an access door, the wheel can be cleaned through this opening. If no door is supplied, then the inlet cone must be

removed to expose the wheel. If for some reason the wheel is removed from the shaft, take note of the "A" dimension called out in the chart below. This dimension must be held if the proper performance is to be maintained.

2. **V-BELT DRIVE:** Check V-belt for proper alignment and tension. (See General Installation and Maintenance Manual IM-101.)
3. **FAN BEARINGS:** Lubricate the bearings as detailed in the ball bearing lubrication instructions in the General Installation and Maintenance Manual (IM-100).
4. **SCREWS AND BOLTS:** Check tightness of all screws and bolts throughout the assembly.

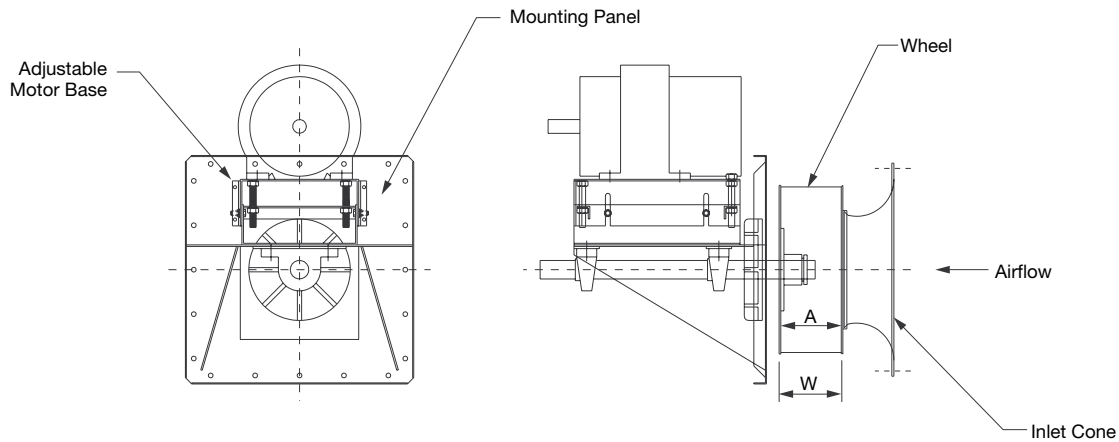

SIZE	A	W
12	4 ⁵ / ₈	4 ⁷ / ₁₆
14	5 ⁷ / ₃₂	5 ¹ / ₃₂
16	5 ²⁷ / ₃₂	5 ²¹ / ₃₂
18	6 ²¹ / ₃₂	6 ³ / ₈
20	7 ³ / ₈	7 ¹ / ₁₆
22	8 ¹ / ₄	7 ¹⁵ / ₁₆
25	9 ⁵ / ₁₆	8 ¹⁵ / ₁₆
28	10 ¹⁷ / ₃₂	10 ¹ / ₁₆
32	11 ²⁷ / ₃₂	11 ¹¹ / ₃₂
35	13 ¹⁵ / ₁₆	12 ³ / ₄
39	14 ²⁷ / ₃₂	14 ³ / ₁₆

"A" dimension (inlet cone to wheel back plate) must be held. This dimension is critical to fan performance. "A" dimension shown is based on 100% wheel width and must be adjusted if wheel furnished is other than 100% full width.



AEROVENT | WWW.AEROVENT.COM

5959 Trenton Lane N | Minneapolis, MN 55442 | Phone: 763-551-7500 | Fax: 763-551-7501