



Direct Fired Air Make-Up Unit

IM-500
August 2013

General Installation, Operation and Maintenance Instructions For Aerovent Products

Throughout this manual, there are a number of HAZARD WARNINGS that must be read and adhered to in order to prevent possible personal injury and/or damage to equipment. Two signal words "WARNING" and "CAUTION" are used to indicate the severity of a hazard and are preceded by the safety alert symbol.



WARNING

Used when serious injury or death MAY result from misuse or failure to follow specific instructions.



CAUTION

Used when minor or moderate injury or product / equipment damage MAY result from misuse or failure to follow specific instructions.

NOTICE

Indicates information considered important, but not hazard-related.

It is the responsibility of all personnel involved in installation, operation and maintenance to fully understand the Warning and Caution procedures by which hazards are to be avoided.

Table of Contents

Unit Information	1
Special Precautions	2
Installation Codes	2 - 3
Unit Location Restrictions	3
Sound and Vibration Information.....	3
Installation Information	3 - 5
Electrical Installation	5
Gas Piping Installation	5 - 7
Operating Instructions and Parts.....	7 - 12
Start-Up Procedure	12 - 14
Sequence of Operation.....	14 - 15
Circuit Analyzer/Troubleshooting	15 - 16
Maintenance Recommendations.....	16 - 18
Terms & Conditions/Warranty	19 - 21
Start-Up Report	22 - 24

FOR YOUR SAFETY

If you smell gas:

1. Open windows.
2. Do not touch electrical switches.
3. Extinguish any open flame.
4. Immediately call you gas supplier

Gas-fired appliances are not designed for use in atmospheres containing flammable vapors or duct, or atmospheres containing chlorinated or halogenated chlorinated or halogenated hydrocarbons.

Recirculation of room air may be hazardous in the presence of: a) flammable solids, liquids and gases; b) explosive materials (ie., grain dust, coal dust, etc.); and c) substances that may become toxic when exposed to heat.

An electrical disconnect must be installed having adequate ampacity (see marking on the heater for voltage and ampacity), if the unit was not provided with one. This disconnect shall be installed in accordance with Article 430 of the National Electrical Code, ANSI/NFPA 70.

This manual is the property of the owner. Please be sure to leave it with them when the installation and start-up of this equipment has been completed.

As Aerovent has a continuous product improvement program, we reserve the right to change designs and specifications without notice.



WARNING

Improper installation, adjustment, alteration, service or maintenance can cause property damage, injury or death. Read the installation, operating and maintenance instructions thoroughly before installing or servicing this equipment.

FOR YOUR SAFETY

The use and storage of gasoline or other flammable vapors and liquids in open containers in the vicinity of this appliance is hazardous.

Aerovent Regional Office

800 S. High St.
Covington, OH 45318
(937) 473-3788

Aerovent Headquarters

5959 Trenton Lane
Minneapolis, MN 55442
(763) 551-7500

Recirculating Units



WARNING

On heaters which recirculate air, outside ventilation air must be provided in accordance with the information shown on the heater nameplate.

Building Relief

Adequate building relief MUST be provided so as not to overpressure the building when the heating system is operating at its rated capacity. It should be noted that this can be accomplished by taking into account, through standard engineering methods, the structure's designed infiltration rate; by providing properly sized relief openings; or by interlocking a powered exhaust system; or by a combination of these methods.

Control Wiring

Entry for control wiring should be ran into the control room provided. Please consult unit drawing and locate the control room on that drawing.

REFER TO THE HEATER RATING PLATE FOR DETERMINING THE MINIMUM GAS SUPPLY PRESSURE FOR OBTAINING THE MAXIMUM GAS CAPACITY FOR WHICH THIS HEATER IS SPECIFIED.

Insulated Units

It is NOT recommended that a recirculation unit be installed in a building that is NOT insulated where the outside air temperature falls below 32° F.

Ventilation Air

Excessive recirculation or insufficient ventilation air, which results in inadequate dilution of the combustion products generated by the heater, may create hazardous concentrations of carbon monoxide, nitrogen oxide, and other combustion products in the heated space.

Fossil Fuel Powered Equipment

If gas fork trucks or other fossil fuel powered equipment are utilized in the conditioned area, additional ventilation requirements for the facility must be addressed separately.

Applications

If there is any doubt in the application of this heater, consult the manufacturer.

Ventilation Air

All ventilation air to this heater MUST be ducted directly from the outdoors.

Interlocks

If failure or malfunction of this heater creates a hazard to other fuel burning equipment in the building (e.g. when the heater is providing make-up air to a boiler room), the unit is to be interlocked to open inlet air dampers or other devices.

Inlet Ducts

When inlet ducts are installed, the heater MUST exchange the air inside the duct a minimum of 4X prior to an ignition attempt. Please consult the manufacturer for instructions.

Special Precautions



WARNING

The installation and maintenance instructions in this manual must be followed to provide safe, efficient and trouble-free operation. In addition, particular care must be exercised regarding the special precautions listed below. Failure to properly address these critical areas could result in property damage or loss, personal injury or death.

1. In Canada, only 100% outside air unit may be installed. They must be solely for replacing exhausted inside air with heated air.
2. Unit must be installed such that no source of flammable vapor, gases or dust is located within 20 feet horizontally of the unit, unless that source is separated from the unit by an enclosure of fire and vapor resistive materials.
3. Disconnect all power before making wiring connections to prevent electrical shock and equipment damage. All units must be wired in strict accordance with the wiring diagram furnished and the NEC.
4. Turn off all gas before installing equipment.
5. Gas pressure to the unit controls must never exceed the gas supply pressure on the data sheet. The unit and its individual shutoff valve must be disconnected from the gas supply during any pressure testing of gas supply piping system at pressures greater than the supply pressure shown on the unit's data sheet. (Maximum pressure to the unit shall never exceed 5 psig.)
6. Check the gas supply pressure at the pressure gauge upstream from the pressure regulator. A pressure regulator, which will satisfactorily limit the gas supply pressure, must be installed with each heater. Purging air from gas lines and piping must be performed as described in ANSI Z223.1, latest edition, "National Fuel Gas Code" (or CAN/CGA-B149 codes in Canada). **STRAINERS BETWEEN THE SUPPLY LINE AND AIR MAKE-UP UNIT ARE HIGHLY RECOMMENDED.**
7. Check damper operation to insure damper blades travel to their full open position and that the damper end switch is functioning properly.
8. To prevent unit or building structural damage, do not operate unit where combustion air may be exposed to chlorinated, halogenated or acid vapor laden air.
9. Minimum clearances to combustibles must be maintained. The minimum clearances to be maintained are 6" from the top, ends and sides of the unit. Allow a 36" minimum clearance on the sides of the unit for servicing. Access doors are provided for servicing the gas controls, electric components and drive adjustment. The unit must be installed such that the surface temperature of any adjacent combustible material shall not exceed 90° F above an ambient temperature of 77° F.
10. Do not block or modify combustion or ventilation air openings. Installation must conform to all local codes, or in the absence of local codes, with National Fuel Gas Code, ANSI Z223.1, latest edition (in Canada install according to CAN/CGA-B149, Installation Code for Gas Burning Appliances and Equipment" or CAN/CGA-B149-2, "Installation Code for Propane Burning Appliances and Equipment").
11. Do not operate unit without exhaust fan or fans operating. Insure proper interlock with exhaust fan system. Direct-fired units operate by heating air directly when the air is passed over the burner flame. On initial burner start-up, or on burner shut down some gas odor may be detected. The presence of gas odors under these temporary intermittent conditions does not indicate an equipment problem, nor do they indicate a hazardous or unsafe operating condition. Direct-fired equipment is not recommended for installations that may be highly sensitive to temporary gas odors. If gas odors persist after initial burner ignition, or for extended periods after burner shut down, discontinue use of unit and call a qualified service technician.
12. Installation in airplane hangars must be in accordance with the Standard for Aircraft Hangars, ANSI/NFPA 409 and in public garages in accordance with the Standard for Parking Structures, ANSI/NFPA
13. Use spreader bars when lifting equipment.
14. Consult piping, electrical and venting instructions before installation. Keep all literature shipped with the unit for future servicing. Leave all literature with the owner.
15. If the failure or malfunction of this heater creates a hazard to other fuel burning equipment in the building, the unit must be interlocked to open inlet air dampers or other such devices.

Installation & Manufacturing Codes

Manufacturing:

- A. The units as constructed conform to ANSI Air Make-Up std. Z83.4, Z83.18, Z223.1, and HFPA54.
- B. Wiring within the control panel meets and carries the UL508 label and meets ANSI/INFPA #70-1987.
- C. Piping within the unit meets ANSI Code Z223.1 National Fuel Gas Code.
- D. Fan performance tested in accord with AMCA 210.
- E. Fan Sound tested in accord with AMCA 310.
- F. Insurance codes IRI and FM as requested.
- G. Equipment components supplied carry the UL electrical listings.

Installation codes governing unit installation by contractors:

- A. ANSI Z83.4, Z83.18, or Z223.1 (latest edition) as applicable.
- B. All installation of this equipment must be performed by a qualified installation agency only defined in ANSI Z223.1.
- C. Electrical ANSI/NFPA #70-1987.
- D. Aircraft hangar NFPA 409.
- E. National Fuel Gas Code NFPA 54.
- F. Installation of air conditioning and ventilating systems NFPA 90A.
- G. Parking Structures and Repair Garages NFPA 54.1.

Unit Location Restrictions and Considerations

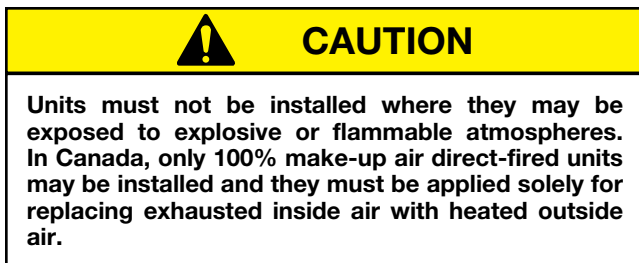

1. Do not locate any gas-fired equipment where chlorinated or acid vapors are present in the combustion air atmosphere.
2. When locating units, consider general space and heating requirements and availability of gas and electrical supply.
3. Maintain minimum clearances to combustibles. The minimum clearances are, 12" from the top, 12" from the bottom, 12" from the sides, and 12" from the ends.
4. Where necessary to provide working clearance beneath the unit, the unit shall be installed at a suitable height above the floor or otherwise adequately protected.
5. Allow 36" clearance on both sides of the unit for service access.
6. Do not modify or block combustion or ventilation openings. Do not modify burner profile opening.
7. Do not install direct-fired units down stream from any cooling system that utilizes refrigerants for cooling.
8. Be sure the structural support at the unit location is adequate to support the weight of the unit.
9. Units require field support of the accessory filters and inlet hood.
10. Some models may be split shipped to accommodate maximum shipping widths. When assembling unit sections, make sure that the sections are properly caulked and secured before operating the equipment.
11. Provide sufficient airflow across the burner. Refer to unit data sheet for required airflow (cfm).

12. Units with motor horsepower below 7.5 hp are supplied with an adjustable motor sheave. Units with 7.5 hp motors and above are supplied as standard with fixed motor and blower drives. Units are supplied from the factory with drives set for static pressure conditions provided at the time of order. Check to make sure the actual job site conditions match the conditions for which the unit was ordered. If proper airflow cannot be established with the drives furnished with the unit, contact the factory for information on drive changes.
13. For economical installation and operation, locate each unit close to the space it will serve, and close to the utilities that will serve the unit.

Site Preparation

Before attempting to install the unit, be sure the site is properly prepared.

1. Make sure there is enough clearance around the installation site to properly and safely rig and lift the equipment.
2. Watch for overhead power lines, or nearby utilities to prevent accidental contact and damage.
3. Make sure the unit supports are adequate to support the equipment.

Sound and Vibration Levels

All mechanical equipment generates some sound and vibration that may require attenuation. Locate the equipment away from critical areas whenever possible. Frequently units can be mounted above utility areas, corridors, restrooms, and other non-critical areas. Generally a unit should be located within 15 feet of a primary support beam. Smaller deflections mean less vibration and noise transmission.

Field installed, factory supplied vibration isolators are available for suspended or rail/slab mounted units. Internal, factory mounted blower and motor isolation may be ordered as an option at the time the unit is ordered.

Installation

Duct Connections

To assure proper airflow from the discharge of the unit follow these recommendations:

1. Be sure properly sized and designed discharge ducts are installed. Velocities should be selected from 2,000 ft/min to no more than 3,000 ft/min for optimum efficiency of operation.
2. Units should have a common discharge plenum of at least three (3) hydraulic duct diameters.

3. As a general rule, all discharge ducts should have a straight run of at least three (3) hydraulic duct diameters before making turns in the ductwork.

Hydraulic Duct Diameter for Rectangular Ducts
= Dh = 4A/P

Hydraulic Duct Diameter for Circular Ducts
= Dh = D

Where:

Dh = Hydraulic Diameter

A = Cross Sectional Area of Rect. Duct

P = Perimeter of Rectangular Duct

D = Diameter of Round Cut

Return ducts should be designed in the same manner. Where ductwork (or other enclosure) is installed to the inlet or outlet of the unit in such a way as to cause a possible gas trap and accumulation of a flammable mixture, a pre-purge cycle shall be incorporated to provide not less than 4 complete air changes to the ductwork (or enclosure) by volume prior to an ignition attempt.

Fire Dampers

Fire dampers installed in the inlet or outlet duct systems shall be provided with electrical interlocks connected in the safety limit control circuit so as to cause the heater to shut down in case of fire in the ductwork, or heater. The **electrical interlocks** must be so arranged that the safety circuit is electrically energized only when the fire damper is in the wide open position.

Utility Connections

Electric and control connections can be made from the side or the bottom of the unit. The factory supplied gas connector is located on the side of the unit. The units normally are supplied with factory mounted disconnects; holes can be cut in the fixed side panels, or bottom of the unit for electrical connections. Sealing of holes cut in the unit casing for utility connections should be done with care to prevent air and water leaks. All external wiring connections for outdoor units must be made with seal tight conduit. All wiring must be in accordance with the National Electric Code.

Rigging Instructions

Each unit is supplied with four mounting and lifting brackets with 1" clearance holes for lifting hooks. **When units are supplied with factory mounted accessories, "DO NOT use the accessory lifting eyes to support the load of the unit"**. The accessory lifting eyes should only be used to steady the load. The main load should be placed on the unit's lifting lugs.

The unit lifting lugs are supplied at the top of the Aerovent units and provide maximum strength for lifting. **In order to lift the unit without damaging the case, SPREADER BARS MUST BE USED!**

A bead of caulking must be applied to the face of all flanges just prior to mounting and bolting. Then, bead should be applied to outside seams after installation. **CAULKING IS NOT SUPPLIED WITH THE UNIT!**

Unit Installation

Follow the site preparation instructions for applicable curb, rail, or slab mounted as noted in this section of the manual. Check the nameplate of the unit before lifting to insure that the model and serial number shown matches that shown on the shipping papers. Check unit dimensions and mounting holes prior to installation to ensure smooth installation experience.

If the unit is mounted on a factory supplied curb:

1. Install roof curb using roof curb instructions (as noted in this section of the manual).
2. Thoroughly clean and dry the top of the curb surface.
3. Attach a curb gasket around the top perimeter of the curb.
4. Lift the unit into place and set the unit down evenly on curb. Check to make sure unit is level and is firmly seated on all corners of the curb.
5. If units are supplied with accessories for field mounting, attach all accessories after the unit has been set in place.
6. Make final unit connections to the electric power supply and remote control circuits. Connect gas lines.

NOTICE

Blow lines clean of shavings and sealant before connecting to the unit pipe train (strainers are recommended between gas supply lines and manifold pipe train). Caulk all utility clearance holes and seams on the unit after connections have been made.

If the unit is to be rail or slab mounted, use similar directions as noted in this installation section.

Slab Mounted Units

For ground level installation of unit, prepare a level concrete slab at least 4" thick and extending 6 inches beyond the unit on an adequate footing and a generous bed of gravel for proper drainage. The slab should include threaded anchor bolts to fit mounting holes and spaced according to unit mounting dimension per unit drawings for securing the unit in place. The anchor bolts should extend at least 2" above surface of the mounting slab to allow clearance for mounting washers and nuts (bolts, mounting washers, and nuts by others).

Other Notes:

Units are not always shipped in one piece. Some field assembly is typically required. Hardware is included; sealant and gaskets are not in all cases. FCBT units include a sealing tape for the flanges. ALL others units do not include any sealants. Please contact your local representative for the breakdown of the number of pieces prior to shipping.

Aerovent ships units in the most economical way. Should it be desired to ship a larger or vertical unit in one piece, please contact your representative immediately.

Inspect all seams after installation and recaulk as needed. A small hole in the caulk or a seam not caulked will allow water penetration.

Roof Curb Mounted Units

Roof curbs should have a minimum height of 14". 24" high roof curbs are available and raise the unit above roof water and snow levels where required and are special ordered. The curb can be installed with the roof in advance of the unit. The curb is shipped knocked down with separate instructions for its assembly, flashing, and sealing with the roof.

Rail Mounted Units

To ensure longevity and integrity of the section joints, continuous rail mounting is preferred.

When rail mounting the units, use two continuous rails for the length of the unit (in direction of airflow).

Where V-bank filters, dampers, and inlet hoods are supplied additional supports are not required, as structural design of accessories will support these items. However, rails should be extended to support cross members of the accessories. Check the drawings in the front of this manual.

Electrical Connections

 CAUTION
Disconnect power source before making wiring connections to prevent electrical shock and/or equipment damage.

 WARNING
All units must be wired strictly in accordance with the wiring diagram furnished with the unit and in accordance with the national electric code ANSI/NFPA 70, latest edition. Unit must be electrically grounded in conformance to this code. Any wiring different from wiring diagram supplied should be cleared with factory engineering with written approval for validation of unit warranty.

Any damage to, or failure of this equipment caused by incorrect wiring of the unit is not covered under the standard product warranty.

Electrical wiring diagrams are furnished with each unit and can be found in the O&M manual, and a permanent laminated diagram is located on the inside of the electric control cabinet door. All units are supplied with a labeled terminal strip for ease of wiring.

The power supply to the standard unit is protected with a lockable type fused disconnect switch. If a disconnect switch is not supplied with the unit, the field supplied disconnect must have adequate ampacity and must be installed in accordance with Article 430 of the National Electrical Code, ANSI/NFPA 70.

External electrical service connections which must be made include:

1. Main power supply to unit (120, 208, 240, 480, or 575 volt).
2. Remote control panel. Consult unit wiring diagram.
3. Separate 120V service for lighting and receptacles as required.
4. Control wires connected to the remote temperature selector must not be run close to or inside conduit with power or ignition wires. Doing so may cause the unit to function erratically or may destroy the amplifier. If shielded wires are used, shield must be insulated and grounded at the amplifier location only.

Supply voltage must be within 10 percent of the power rating with each phase balanced to within 2 percent of each other. If not, advise the power company.

Before powering unit, make sure all multi-voltage components (transformers, motors, etc.) are wired in accordance with the correct supply voltage.

The lighting circuits and unit receptacles require the installation contractor to supply a separate 120 volt single supply source to the unit and be installed in accordance with Article 210 of the National Electrical Code ANSI/NFPA 70 - 1987.

Gas Piping Installation

 CAUTION
Gas pressure to main gas manifold must NEVER EXCEED 5 psi.

The unit and its individual shutoff valve(s) must be disconnected from the gas supply during any pressure testing of the piping system. Before assembling piping to unit manifold contractor should be sure all rust, piping compound and shavings have been removed from new piping. (Strainers are recommended between unit pipe train and supply piping.)

Always check the unit's data form to determine the correct gas supply pressure for which the unit was designed.

1. Installation of piping must be in accordance with local codes, and ANSI Z223.1, latest edition, "National Fuel Gas Code". (In Canada CAN/CGA-B149 Code).
2. Piping to units must conform to local and national requirements for type and volume of gas handled, and pressure drop allowed in the line. Refer to the air make-up data form to determine the Btu capacity of the unit and the type of gas the unit is designed to use. Using this information refer to the ASHRAE Guide Fundamentals Handbook, or other gas pipe sizing guide to determine the correct supply pipe size. Allow sufficient pipe size based on allowable pressure drop in supply

line. Where several units are served by the same main, the total capacity of all the units served by the main must be used. Avoid pipe sizes smaller than 1/2".

3. After threading and reaming the ends, inspect piping and remove loose dirt and chips.
4. Support piping so that no strains are imposed on the unit controls.
5. Use two wrenches when connecting field piping to units.
6. Provide a drip pocket before each unit and in the line where low spots cannot be avoided.
7. Take-off to unit should come from top or side of main to avoid trapping condensate.
8. Piping subject to wide temperature variations should be insulated.
9. Pitch piping at least 1/4" per 15 feet of horizontal run.
10. Compounds used on threaded joints of gas piping must be resistant to action of liquefied petroleum gases.
11. Purge air from gas piping before lighting unit.
12. After air has been purged, check for gas leaks in the piping system using a soap water solution.
13. Install a ground joint union and gas cock external of the unit for easy servicing of controls.
14. Allow at least 5 feet of piping between any high pressure regulator and the unit control pipe train.

Gas Supply Pressure – 5 lbs. or less

The Aerovent air make-up unit is standardly furnished with the Maxitrol modulating system. This device controls the firing rate of the burner to maintain the desired operating temperature.

It functions as a regulator and modulator which will not allow the burner manifold pressure to exceed that which produces the maximum firing rate, and also will reduce the pressure below this value to modulate the burner throughout the normal 25 to 1 turn down ratio. The upstream pressure supplied to the unit pipe train must not exceed 5 pounds. This is the maximum for suitable operation. The minimum operating pressure will vary depending upon the unit size and pipe train size. This pressure is marked on the pressure gauge. As long as the gas pressure supplied to the unit is maintained at some value between the minimum as marked on the gauge and 5 pounds maximum, the air make-up unit will perform at its rated capacity.

If the gas supply system is designed for a pressure higher than 5 pounds, it is necessary to install an additional regulator upstream of the connection to the unit. See following instructions for gas supply over 5 pounds.

The downstream pressure from the line regulator will vary somewhat depending upon the firing rate of the air make-up unit. Variations can also be caused by other gas equipment connected to the distribution system. It is necessary, therefore, to be sure that the setting of the supply line regulator is such that the pressure supplied to the unit will always be at least equal to the minimum and not exceeding 5 psi.

NOTICE

Do not vent the vent valve and pressure regulator in the same vent pipe. Separate vent lines to outside atmosphere must be run for the unit to operate properly. Combining the vent lines to atmosphere will cause the high limit gas pressure control to lock out the flame safety system and shut down the unit.

NOTICE

A pressure regulator may be required to meet the state or local code. Consult your standards.

Gas Supply Pressure – Over 5 lbs.

When the supply line pressure to an air make-up unit exceeds 5 pounds or may at times fluctuate above 5 pounds, it is necessary to install a line pressure regulator ahead of the input to the air make-up unit. The size must be selected to handle the maximum capacity of the unit, and the type of regulator selected to work at the maximum inlet pressure and having a capability of maintaining the outlet pressure at some value between 8 ounces and 5 pounds. As a rule, the outlet pressure from the line pressure regulator may be adjusted anywhere between 2 and 4 pounds. If the regulator was furnished by Aerovent, it has been sized according to the information in the original order and shown on the parts list. Regulators are sized according to capacity and pressure and not according to pipe size; therefore, the size of the pipe at the inlet to the air make-up unit may not be the same as the pipe size of the regulator.

To be sure the supply line is properly sized, it is suggested that the representative of the local gas company be consulted about pipe sizing. The line regulator should be installed close to the air make-up unit. There should be no elbows, couplings, valves, or fittings within at least ten pipe diameters of the inlet and the discharge of the pressure regulator. A shut-off cock should be placed upstream of the regulator so that it can be removed for servicing if necessary. It is a good idea, also, to install a pressure gauge

Figure 1. Typical Gas Regulator

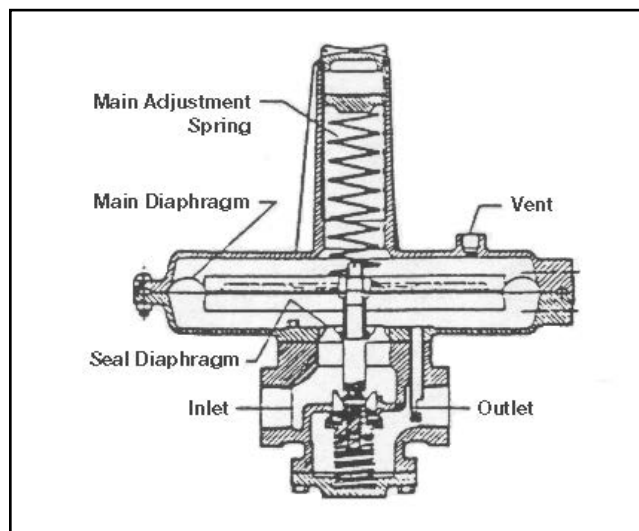

on the upstream side having a scale range sufficient to indicate the supply line pressure.

It is very important to connect the regulator vent with pipe or tubing extended to the outside with the end protected from the weather. Do not vent the regulator into the air make-up unit or the duct system, or near the inlet to the air make-up unit.

NOTICE

Do not vent the vent valve and pressure regulator in the same vent pipe. Separate vent lines to outside atmosphere must be run for the unit to operate properly. Combining the vent lines to atmosphere will cause the high limit gas pressure control to lock out the flame safety system and shut down the unit.

Figure 2. Piping Configuration

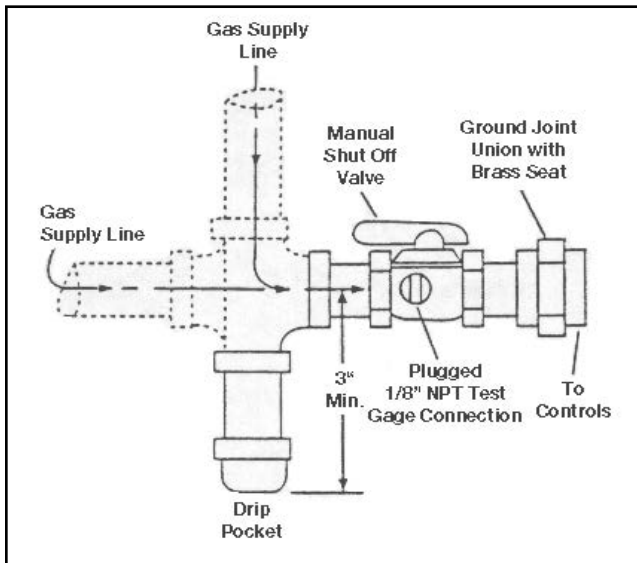

Operation Instructions

PRIOR TO OPERATION

Although this unit has been assembled and test fired at the factory, the following pre-operational procedures should be performed to assure the unit has not been damaged or misaligned during shipment. This will help assure proper on-site operation.

1. Remove all shipping straps, braces, and tie-downs.
2. Check burner to insure proper location and if airflow is moving across burner correctly. The burner may be wrapped, if so remove wrapping. This is important if unit was split for shipping convenience. Also check to be sure sections were caulked when assembled.
3. Check blower and motor sheave alignment, as well as belt tension.
4. Check bearings for alignment and tightness of mounting bolts, bolts securing taper lock bushings to shaft, and that locking collars are secure.
5. Check all electrical connections to insure wires are making good contact and are secure in their terminals. Check tightness of jumpers between terminals.
6. Check gas piping for leaks using a soap/water solution.

After these preliminary checks have been made, the unit can be prepared for start-up.

Start-Up and Check Out

Each unit is supplied with a service manual which includes a Field Start-Up Form. **The Field Start-Up Form must be followed and properly filled out and signed by the installer. It then is to be mailed or faxed back to Aerovent, 800 S. High St, Covington OH 45318. The fax number is (937) 473-3793.**

Before continuing with the start-up and checkout procedure, **it is important to familiarize yourself with the safety controls furnished with the unit.**

Airflow Proving Switch

(Aerovent Part #19240-01)

The airflow proving switch monitors the differential pressure across the venturi sensor located at the burner profile plate to insure that sufficient airflow exists before allowing the burner to operate. The airflow proving switch is located in the gas controls cabinet and is electrically interlocked with the flame safeguard control system. The air flow venturi is located at the burner profile plate with pressure taps leading from that location to the pressure switch. The venturi amplifies the signal to the pressure sensing device and minimizes nuisance shutdowns.

High Temperature Limit Control

(Aerovent Part #18756-01E)

The high temperature limit control shuts down the burner if excessive discharge temperatures are experienced. The limit control is located in the blower discharge air chamber. The limit control is electrically interlocked with the flame safeguard control relay.

Figure 3.

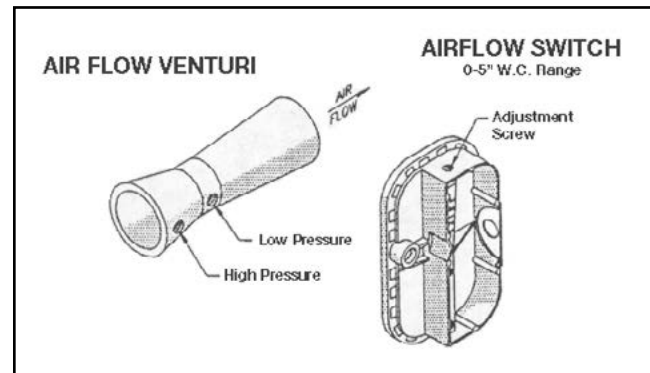
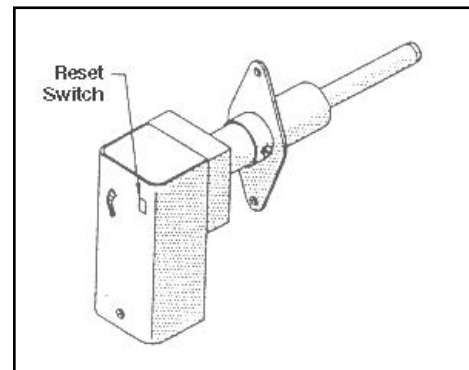

Figure 4. High Temperature Limit



Flame Safeguard Control

(Aerovent Part #25941-01)

All units are equipped with a Honeywell RM7895C flame safety relay. This relay senses if a pilot flame and main burner flame have been established through the use of an ultraviolet (UV) scanner. For more information about the Honeywell flame relay, visit the Honeywell web site.

The flame safeguard relay has a built in component self checking module, pre-purge timer, and an ignition timing flame sensing circuit. The pre-purge timer allows purging of any residual gas or fumes in the unit before a try for ignition. Pre-purge is approximately 10 seconds. After pre-purge occurs, the spark ignition will start. If the pilot flame is not proven within the time period allowed (10 to 25 seconds) the relay will go into lockout and it will have to be manually reset before a try for re-ignition can occur. This can be accomplished by pressing the reset button on the remote station or at the unit thus preventing a trip to the air make-up unit. If after several (2-3) tries the unit won't light off, have a maintenance man inspect the unit to determine cause of relay lockout. **Note:** The power light will blink; this is a normal operating condition.

Figure 5. Flame Relay

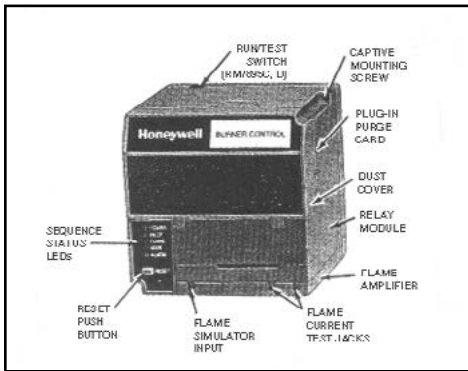

C7027 Ultra Violet Scanners

(Aerovent Part #2281-01E)

Units are equipped with a C7027A UV scanner. This device is shipped removed from the flame sighting tube to prevent damage during shipment. Unwrap the device and mount on the sighting tube. The UV scanner is a ultra-violet light sensing device. It takes advantage of the fact that a flame will emit some of its light in the low frequency ultra violet light range. The scanner uses an electronic eye to scan for the presence of this ultra violet light. If flame is detected, it sends this signal to the RM7895C flame relay.

Figure 6. UV Flame Detector (Purple Peeper)

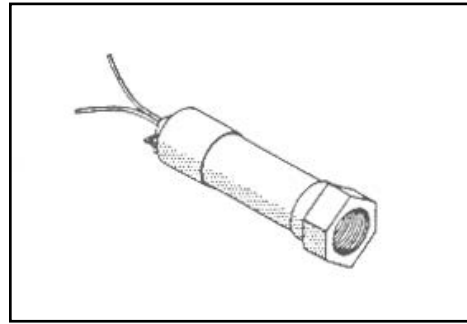

Gas Pipe Train Configuration

(Aerovent Part #2281-01E)

The type of manifold supplied with the unit varies depending on whether the unit was ordered with a FM or IRI manifold. To determine which arrangement was supplied with the unit, see the manifold descriptions noted on the product specification and general description page in the front of this manual.

Figure 7. FM Piping

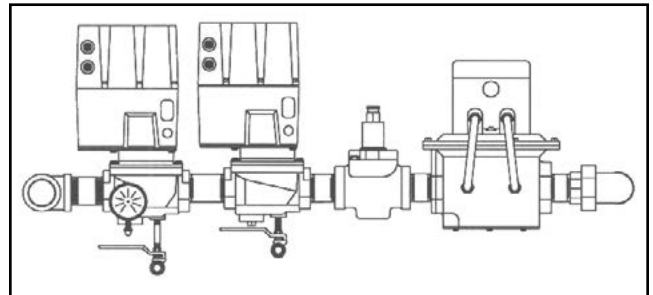
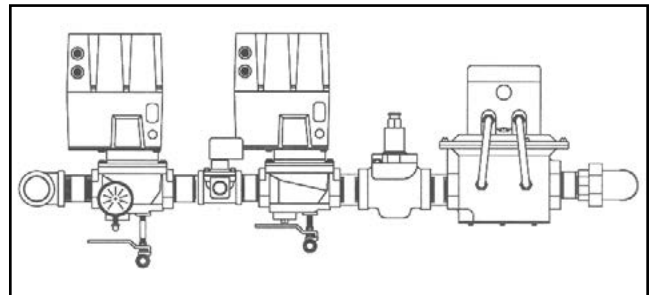

Figure 8. IRI Piping



Pilot Solenoid Gas Valve

(Aerovent Part #422-05E)

The pilot solenoid gas valve serves as a separate shut-off valve for the pilot gas during normal operation and provides means for interrupted pilot and main flame supervision during normal operation of the unit.

Figure 9. Pilot Valve

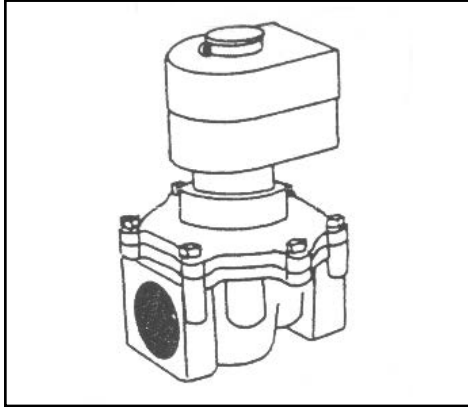

Adjustable Pilot

(Aerovent Part #1192-01E)

The pilot is properly adjusted at the factory; however, the conditions of the installation can affect this pre-adjusted pilot so that it may require resetting. The pilot has a needle valve adjustment under the brass screw cap. Remove the brass screw cap to make the pilot flame adjustment. The pilot works best with the smallest possible flame, and this is usually with the needle valve screw backed out $\frac{1}{2}$ to $1\frac{1}{2}$ turns from the fully closed position.

Figure 10. Adjustable Orifice

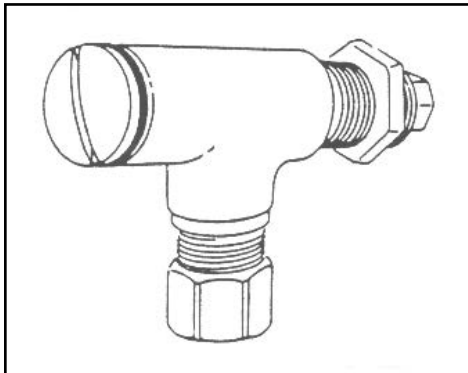

There are three (3) fully modulating temperature control systems offered:

1. OUTLET TEMPERATURE CONTROL SYSTEM

(OTC, Series 14) holds constant outlet temperature adjustable at the remote operating station and has outdoor temperature compensation.

The discharge air temperature thermostat actuates the modulating regulator to hold average outlet temperature to a set point located in the remote station.

2. OUTLET TEMPERATURE CONTROL SYSTEM

(OTC-RO, Series 14 w/T115 Override) with room override (Optional) A T115 room space temperature control increases the discharge air temperature until room temperature is satisfied. The room set point is adjustable. This system does not allow a room to fall below the set point of the Room Override thermostat. Once the room thermostat is satisfied, the temperature is then backed down to the TD114 set point. The increase of temperature is controlled set by a selector dial on the back of the TD114.

Discharge air temperature thermostat automatically limits extreme changes in discharge temperature.

3. MODULATED ROOM TEMPERATURE CONTROL

(MRTC, Series 44) (Optional) maintains room temperature within very narrow limits, provides extreme accuracy and rapid response to small temperature changes. Compensates for process heat while maintaining the room temperature.

Go to the Maxitrol web site at www.maxitrol.com for the Maxitrol bulletin that pertains to the system supplied with your unit. The front specification page lists the type of temperature control system.

Maxitrol Temperature Control Modulating Gas Valves (MR212 valve)

Units are supplied with a Maxitrol Series 14 or 44 temperature control modulating system. The Maxitrol temperature control responds to a DC voltage signal from the Maxitrol Series 14 or 44 amplifier. When the DC voltage is in the range of 0 to 5 volts the main valve is at low fire; modulates between 5 and 15 VDC; at 15 volts the valve is full open and is at high fire operation. As the DC voltage changes, a solenoid valve in the main valve modulates. Low fire is accomplished by means of a mechanical bypass built into the valve body. This adjustment is located under the valve cover and should be adjusted on all installation start-ups.

Figure 11. MR212 Valve

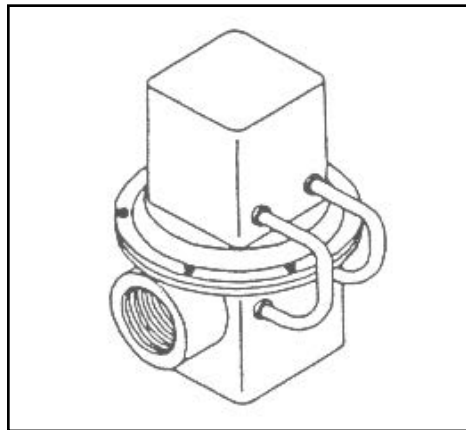

Maxitrol Modulating Valve Adjustment

NOTICE

Low fire adjustment should be checked whenever the high fire adjustment is changed.

Figure 12.

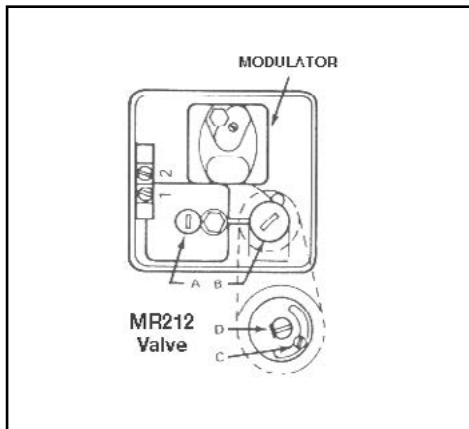

High Fire Manifold Adjustments

1. Disconnect wires from terminals #2 and #4 on the A1044 or #4 on A1014 Amplifier. This causes the valve to call for continuous high fire.
2. Remove seal cap (A), Figure 12, and turn regulator pressure adjusting screw to obtain desired manifold pressure. (7 in. w.c. MAXIMUM) (Clockwise rotation increases pressure.) The manifold pressure must not exceed 7 in. w.c. The flame must always be checked visually. The flame MUST be a "clean blue flame". A little yellow tipping is acceptable, but the flame should be blue. The flame length should be a maximum of 10-12 in.
3. Reconnect the wires to terminals #4.

Low Fire or By-Pass Adjustment

1. Disconnect wire from terminal #8 on the A1044 or A1014 Amplifier. This causes valve to call for continuous low fire.
2. Remove cap (B), Figure 12, and loosen lock screw (C). Turn (D) to desired low fire adjustment. (Clockwise rotation reduces minimum flow rate.) Flame should be stable over full length of burner.
3. Tighten set screw (C), replace cap (B) and reconnect wire to terminal #8.

NOTE: This procedure is in the Maxitrol bulletin found at www.maxitrol.com. Please consult it for further information.

Blocking Main Gas and Vent Valve Systems for FM and/or IRI Insurance Requirements

To meet the national insurance requirements of FM (Factory Mutual) or IRI (Industrial Risk Insurers) these controls are furnished in addition to the gas controls required by ANSI.

Motorized Main Gas Valve(s)

FM and IRI (and some local codes) require the use of one or two motorized main gas shut off valves and depends on the BTU input capacity of the burner.

The motorized gas valve contains a heavy duty spring which will return the valve to the closed position if power is interrupted to the valve. The valve uses a hydraulic pump to open the valve. The use of self closing heavy duty return springs provides a positive shut off in the event of a power loss to the valve. A second blocking valve prevents gas escaping into any occupied space should the main gas valve not provide tight shut-off when the unit is shut down.

Figure 13. Valve Actuator and Gas Valve

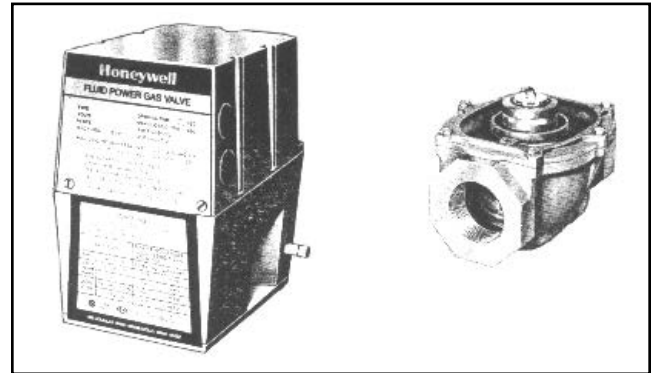

High-Low Gas Pressure Switch (FM/IRI) (Aerovent Part #470-01E)

A high and low gas pressure switch is included with all units. These switches monitor the gas pressure downstream from the safety valves and shuts off the electric supply to the safety valves if excessive or insufficient gas pressure is experienced. This will shut down all gas flow to the burner. The switches must be manually reset when the gas pressure is returned to the set point pressure of the respective pressure switches.

Figure 14. High/Low Gas Pressure Switch

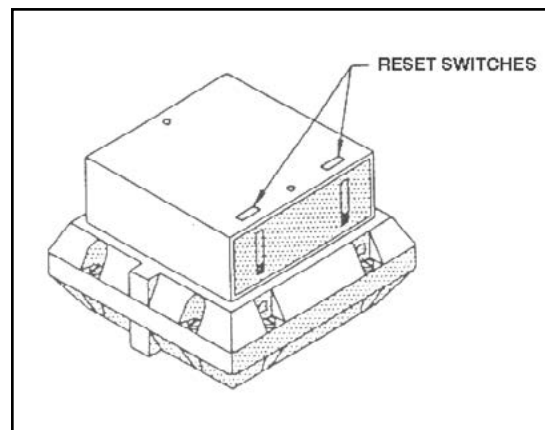

Normally Open Vent Valve

 CAUTION
Units mounted indoors and supplied with a vent valve MUST have the vent valve vented to the outdoors. Venting of the valve is the responsibility of the installer.

Normally, two motorized main gas valves are supplied and an open vent valve is also supplied between the two valves. The vent valve **MUST BE VENTED TO THE OUTDOORS.**

The ASCO vent valve is a normally open solenoid type valve. This valve is normally open when the unit is not operating. It vents the pipe connecting the two safety shut-off valves to the outdoors.

The vent valve should be checked for proper operation at least once a year at the beginning of the heating season. Obviously, if this valve should fail, large quantities of fuel would be wasted, as this would be bypassed to the outside.

The purpose of the vent valve is to divert the gas flow to the outdoors in the event the first motorized valve fails to close during a shut down operating condition.

Figure 15. Vent Valve

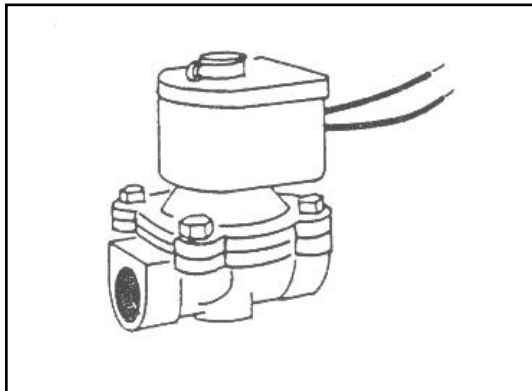

Building Pressure Controls (Optional)

When units are provided with an 80/20 recirculating feature, a separate outside air and return air damper control is supplied with the unit.

The control includes a floating pressure switch. Units utilizing a building pressure control are provided with an outside air burner bypass damper and a return air damper. The outside air burner bypass damper and return air damper are controlled by a floating damper motors. The dampers are connected to the motor by a damper linkage.

The purpose of the building pressure switch is to sense the difference between the indoor building pressure and outdoor atmospheric pressure. This system is used when varying exhaust loads are handled by one make-up air unit.

As more exhaust fans are turned on, pressure in the building will tend to become more negative. The building pressure switch senses this change in pressure and causes the floating damper motor to

Figure 16. Floating Pressure Switch

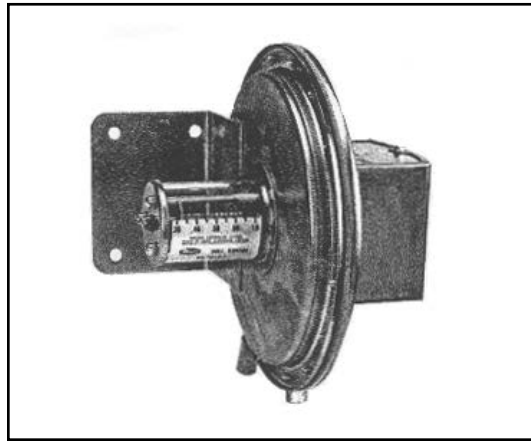

adjust its position to bring the building pressure back to near atmospheric by introducing more outside air and reducing the amount of return air supplied to the unit. The dampers can be adjusted for a maximum of 100% outside air, and a minimum of 20% outside air. When power is interrupted to the motors, the return air damper closes and the profile damper opens. The discharge damper closes also giving a 100% shut-off from outside air.

 CAUTION
The building pressure control's low pressure tap MUST be vented to the outdoors and fitted with a wind and rain shield.

The desired building pressure is maintained by adjusting the pressure set point on the floating pressure switch. The differential is adjusted by the null adjustment in the pressure switch. The smaller the null zone the more sensitive the setting. The larger the null zone, the less sensitive the setting. Settings should be such that the dampers stabilize and hunting of the damper motors does not occur. The larger the null zone the more stable the control loop will be.

Reset Timer

(Aerovent Part #21749-01)

Timed bypass of the low temperature switch. A timed freeze protection system is supplied with most units. This system includes a reset timer and a discharge air temperature sensor (freeze stat). On initial start-up, the reset timer allows the unit to go through the normal ignition sequence. The reset timer is set to engage the discharge air sensor after a period of 3 minutes. In the event the unit fails to fire after this time period the discharge air sensor will sense the cold air and will shut down the entire unit. This is done to prevent freeze up of water lines and minimize discomfort to personnel in the area.

Figure 17. Reset Timer

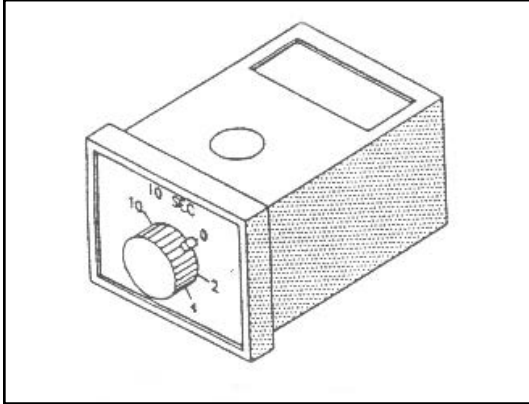

Mild Temperature Control

(Aerovent Part #1175-01E)

A mild weather temperature stat is supplied with most units. The purpose of the mild temperature stat is to shut the main burner down (100%) during mild weather days so undesirable temperature build-up in the space will not occur. This device is normally set at 60 - 65° F. Adjustable.

Figure 18. Mild Weather Control

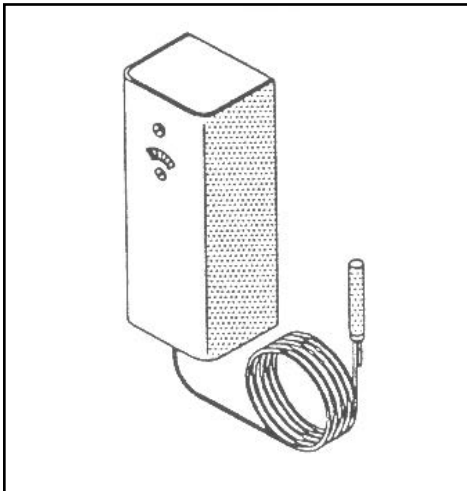

Damper Motor

(Aerovent Part #26758-02 or #26758-20)

The damper is operated with a rotary spring return damper motor capable of 133 in. lbs. of torque. Full opening of the motor requires 120 seconds. An internal adjustable auxiliary switch set at 65° open closes and allows the starter to pull in and start the fan. On power interrupt the motor is driven closed by the spring return device.

Figure 19. Damper Motor

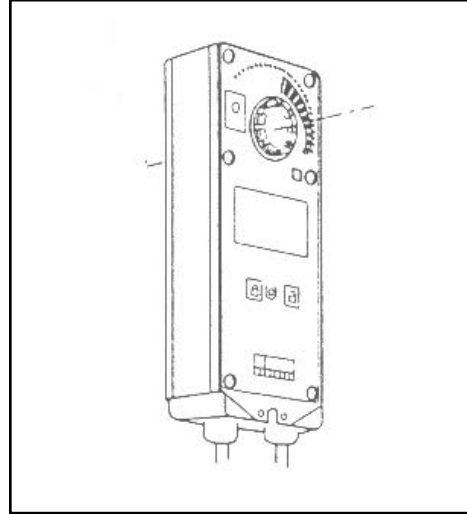

Start-Up Procedure and Check List

After the unit has been installed and the preliminary checks have been made, the following start-up procedure must be performed.

Regulators are shipped separately (or supplied by others) require field adjustment. **It is important to check to make sure that the gas supply pressure to the unit is in accordance with the input pressure rating shown on the unit specification description.**



CAUTION

Check gas supply pressure at the unit upstream from the pressure regulator. Purging air from gas line and piping should be performed as described in ANSI Z223.1, latest edition, "National Fuel Gas Code", or in Canada, CAN/CGA-B149 Codes. Strainers are recommended to prevent foreign material from preventing the safety shut-off valve and blocking valves from properly seating.

To properly perform the start-up, the following instruments are required.

Test Instruments

Volt Meter (25-460 volt) AC

Amp Meter (0-50 amp)

Ohm Meter

Slack Tube Manometer or 0 - 30" w.c. Pressure Gauge

Hand Held or Strobe-Type Tachometer

1. Turn off power to the unit at the disconnect switch. Turn all hand gas cocks to the off position.
2. Set the Summer/Off/Winter switch on the Remote Panel to the "Off" position and all temperature control stats to their lowest setting.
3. Check to see that there are no obstructions to the inlet air supply or the discharge air supply ducts and air make-up compartments (and return air recirculation section if supplied).
4. Check to see that all wiring is secure and properly protected.
5. Recheck belt tension and pulley alignment.
6. Check bearings for proper lubrication.
7. Check to make sure that all filters are in place, and they are installed properly with arrows pointing in the direction of air flow.
8. Perform a visual inspection of the unit to make sure no damage has occurred during installation. Make sure all service doors have been closed.
9. With the Summer/Off/Winter switch still in the "Off" position, energize the electric supply to the unit with the power disconnect switch.
10. Move the Summer/Off/Winter switch to the "Summer" position. The inlet and/or discharge air dampers should open (approximately 120 seconds). When in the 65% open position, the damper end switch should make and allow the blower motor starter to be energized.
11. Turn unit off IMMEDIATELY and check the blower for proper rotation of wheel. Correct if required by reversing two of the three leads supplying power from the starter. If soft start or VFD is installed consult the instruction manual that was included with the unit to change rotation.
12. Turn unit back on and check to make sure that the damper opens fully without binding, also check the motor and blower speed with the strobe for rpm.
13. With the voltmeter check motor voltage on all three phases of the systems to make sure all legs are in balance.
14. With the amp meter check motor amp draw to make sure it does not exceed the motor nameplate rating. On three phase systems, check all legs to insure system is balanced.

NOTICE

The first main gas hand cock will have to be opened at this time and the high and low gas pressure switches must be reset. However, the second main hand valve, (located before the modulating gas valve) should be kept in the closed position.

15. Recheck gas supply pressure. Gage should show pressure as marked at the gage.
16. Check pilot and pilot ignition. Open pilot gas hand cock only.
17. Check to make sure that all manual reset safety devices have been reset to their normal operating position.
18. Move the Summer/Off/Winter switch to "Winter". Move temperature controls to call for heat.

NOTICE

The mild temperature control set point needs to be set above the ambient outside temperature to allow the pilot and igniter to function. (Do not forget to reset to 65°F after final system checks are completed.)

19. Check to see that the pilot lights properly. The spark igniter should begin to spark in approximately 10 seconds and pilot flame should be established within 10 seconds.
20. The unit is supplied with an ultra violet flame detector (UV) scanner. With the UV detector (scanner), the output of the detector should be stable and should be between 1.25 and 5V DC at the flame relay terminals. Adjust pilot regulator if the readings are outside of the specified ranges by removing cap screw and adjusting pilot flame with pilot needle valve. Best results are obtained with smallest possible flame 1/2 - 1 1/2 turns clockwise from fully closed position.
21. Check to make sure the flame sensor and flame safeguard relay is operating correctly. To check, shut off the pilot gas hand valve while the pilot is still on. The pilot igniter should try for ignition within 2 to 4 seconds. If pilot cannot be reestablished, the flame safeguard control should go into lockout. **(If the flame safeguard does not go into lockout, contact factory.)**
22. Turn the pilot gas hand cock to the on position and reset the flame safeguard relay using the manual reset button on the relay. Allow the unit to establish pilot.
23. Check the airflow sensing device switch by blocking off 30% of the inlet to the unit. The system should shut down. With the pilot established, increase the pressure setting of the airflow proving switch by turning the adjustment screw on the switch clockwise. Increase the setting until the pilot drops out. Back off of this setting two turns enough to allow the pilot to reignite. **(If pilot does not drop out during this check, inspect the switch for damage and replace if required.)**
24. Check continuity of limit control contacts and wiring. **(Unit will not try for ignition if limit control is faulty.)** The high limit control is factory set and does not require field adjustment.

NOTICE

The maximum gas pressure gas manifold can safely handle without damaging the controls is 5 PSI.

25. Open main gas cock and check gauge gas pressure reading. The pressure reading on the gauge should be at factory noted hash mark. **(See unit rating or system spec for high fire burner pressure setting. Also see manifold component diagrams.)**
26. **Observe low fire flame to make sure it LIGHTS ACROSS THE ENTIRE LENGTH of the burner is stable and burning with a clean blue flame.**
27. Move the Maxitrol temperature setting control to its highest setting and observe the high fire flame. Make sure that it is stable and burning clean. A slightly orange tip may be evident and is acceptable.
28. High Fire Adjustment: Disconnect lead #4 on series 14 or leads #2 and #4 on series 44 from the amplifier which will cause the burner to go to a high fire condition. The flame length should be 10 in. and burn with a slight orange tip. Adjust the pressure regulator in the Maxitrol valve accordingly by removing the seal cap adj. pressure reg. screw (should give manifold pressure of 7 in.) Return wires to terminals when adjustments are complete.
29. Low Fire Adjustment: Disconnect wire from term #8 in the amplifier. Remove cap and obtain a flame that is a "ribbon" across the entire burner being sure flame is stable. Tighten the setscrew, replace the cap and reconnect wire to term #8.
30. Check the burner gas pressure at high fire to make sure the unit is not over or under fired.

If the burner is not firing at the pressure marked on the unit's gas pressure gauge, adjust the main supply pressure regulator accordingly.

31. After the high fire pressure has been checked and reset if necessary, turn the temperature controls down to their lowest setting and recheck the low fire burner flame. It should still be stable and burning clean.

NOTICE

Recommended frequency of test is once per month.

32. Safety shut off valve leak test. Remove cap from test cock. Close the manual valve on the vent line. The main S.S. and blocking valves are closed. Open the test cock - check for gas leak. If no leak detected close test cock and cap. Open the manual valve in the vent line.
33. Check gas input rate.

Actual input rate should be checked and necessary adjustments made after the unit is installed. Over-firing, a gas pressure result of too high an input, reduces the life of the unit, increases maintenance, lowers burner efficiency and can result in poor combustion. Under no circumstance should the input exceed that shown on the unit specification description.

The following procedure describes how the gas input check is accomplished.

Pressure Method

The pressure method determines input by measuring the pressure of the gas in the burner manifold in inches of water. (Designed for 7 in. w.c. MAXIMUM.)

1. Close manual valve.
2. Remove the 1/8" pipe plug test port at the burner and attach water manometer of "U" tube, which is at least 12" high or pressure gauge calibration with a range of 0 to 15 in. w.c.
3. Open manual valve and start unit.
4. If pressure as indicated by "U" tube or gauge is not more than 1/2" higher or lower than 7 in. w.c. on the system spec description, adjust the Maxitrol gas valve regulator as per the vendor literature that is shipped with the unit.

If pressure as indicated by "U" tube is more than 1/2" higher or lower than 7 in. w.c., check the inlet gas pressure at unit. Adjust main gas regulator to supply the correct gas inlet pressure as described on the unit's system specification description.

Multi-Speed Units

Units with two-speed motors or variable airflow options require the following additional start-up checks.

Two-Speed Units

1. Check the motor and blower speed at both high and low speed.
2. Check motor amps at both high and low speed.

Variable Airflow Units

50/50, 60/40, or 70/30 Options

1. Check to make sure that the outside air burner bypass damper and return air damper operate correctly without binding.

80/20 Building Pressure Control

1. Check that the outside air burner bypass damper and return air damper operate correctly without binding.
2. Check to make sure building pressure control is operating correctly.

The building pressure control is designed to open the outside air burner by-pass damper and close the return air damper as the negative pressure in the building increases.

To check if this is occurring, turn on an exhaust fan and observe the return air damper position. It should start to close. Turn on additional exhaust fans. The return air damper should close further.

With all of the exhaust fans running, the return air damper should be in the fully closed position and the burner by-pass damper should be in the fully open position. Check and adjust as necessary.

After all the initial start-up procedures have been performed, the unit is ready for commissioning. Set the temperature controls for the recommended control safety device settings:

1. High gas pressure switch set at 12 in. w.c.
2. Low gas pressure switch set at 2 in. w.c.
3. High temp thermostat 150° F
4. Low temp thermostat 40° F
5. Mild weather thermostat set at 65° F
6. Reset timer 3 min.
7. Room temp. Set point as desired.
8. Airflow switch approx. 2-3 turns from closed position.
9. Building pressure control 0.01 to 0.03 in. w.c.

If the unit is to be left for stand-by operation, set the Summer/Off/Winter switch to the "Off" position and turn the electric power off at the unit's disconnect switch.

NOTICE

Loss of warranty occurs if warranty start-up report is not submitted to Aerovent.

Warranty Start-up Report

A Start-Up Report form is included in the back of this manual. Before turning the unit over to the owner, make sure the Start-Up Report has been completely filled out, signed, and dated. Submit a copy of the start-up report to Aerovent Company, 800 S. High St., Covington, OH 45318. The fax number is (937) 473-3793.

Operating Sequence

Remote Switch in "Off" Position

With Summer/Off/Winter switch in the "Off" position the unit is shut down and either the blower or burner will operate.

Remote Switch in "Summer" Position

With the remote switch in the "Summer" position, the following sequence of operation will occur.

1. Inlet and/or discharge damper is energized.
2. When damper is 65% open, the internal damper motor end switch will make and allow power to be supplied to the motor or motor starter. Fan will start and supply air to the distribution system. The blower light will come on.
3. The gas controls and temperature controls are locked out to prevent heating during the "Summer" mode.

NOTICE

The burner will not come on with the switch in "Summer". The fan will continue to run as the temperature drops.

Remote Switch in "Winter" Position

If freeze protection is furnished with the unit, the freeze protection timer will be energized at this time to provide power to the inlet and/or discharge damper.

With the remote switch in the "Winter" position, the above sequence continues:

4. The running interlocks supply power to the flame relay through contacts on high temperature limit control and high and low gas pressure switches, mild weather temperature stat, proof of airflow switch, proof of closure switch and freeze protection sensor.
5. After 7 seconds of pre-purge time, the flame safeguard ignition sequence is energized, the ignition transformer is energized and pilot valve is opened.
6. After pilot is lit and proven, the main gas valves are energized and the burner fires at low fire. The burner "On" light is energized on the remote panel when the main valves are completely open and the end switch is made.
7. Burner remains on low fire until the main valves are 100% open and the end switch is made. The temperature controls then take over and modulate burner firing based on load demands.

NOTICE

If the unit has been supplied with a dirty filter switch, the filter light will come on if the pressure drop across the filters becomes excessive.

If a flame failure should occur (lock out time: 17 seconds) the burner light on the remote panel will go out. The flame safeguard relay will go into lockout. The unit selector switch must be turned off before the unit can be restarted again. The flame safeguard reset button (optionally located on the remote station) must be manually reset in order to restart the burner. If you have a remote reset, travel to the unit is not required.



CAUTION

After resetting the reset button on the flame safeguard relay three times and the unit fails to light off, have service department check unit to determine cause of failure.

Using the Circuit Analyzer to Isolate Defective Components

Troubleshooting the Aerovent air make-up control systems has been simplified by the use of the circuit analyzer. The light numbers are the same as the wire numbers for each circuit. They are also arranged to operate in sequence. The analyzer is turned on by the toggle switch. If any circuit is not energized, the sequence will stop at that point until the fan shuts down (approximately 90 seconds). It should be emphasized that the circuit analyzer will show

the location of a malfunction only during the starting cycle. To start a new cycle, turn the unit off, wait 30 seconds, and then turn it on again. Observations are made with the disconnect switch closed and the selector switch in the "Winter" position.

If lamp #3 does not light, check:

1. Is lamp #3 getting power or is the bulb defective?
2. The fuse (Buss FNM 5 amp).
3. Line voltage on the primary side of control transformer.
4. Control voltage on secondary side of control transformer.
5. Jumper between H and 1 on the terminal strip.
6. Continuity between 1 and 3 on the selector switch.

If lamp #4 does not light, check:

NOTICE

May not come on until flame is established.

1. Is lamp #4 getting power or is the bulb defective?
2. Contacts and operation of low temperature limit thermostat (Dial setting 30°). Temp. below setpoint.

If lamp #5 does not light, check:

1. Is lamp #5 getting power or is the bulb defective?
2. Contacts and operation of reset timer.

If lamp #6 does not light, check:

1. Is lamp #6 getting power or is the bulb defective?
2. Operation of shutter motor.

If lamp #7 does not light, check:

1. Is lamp #7 getting power or is the bulb defective?
2. Contacts and setting of mild weather thermostat.
3. Ambient temp above MW setting.

If lamp #8 does not light, check:

1. Is lamp #8 getting power or is the bulb defective?
2. Selector in "summer" position.
3. Continuity between 7 and 8 on the selector switch.

If lamp #9 does not light, check:

1. Is lamp #9 getting power or is the bulb defective?
2. Line gas pressure.
3. Low gas pressure switch. (Manual reset)

If lamp #10 does not light, check:

1. Is lamp #10 getting power or is the bulb defective?
2. High gas pressure switch. (Manual reset)

If lamp #11 does not light, check:

1. Is lamp #11 getting power or is the bulb defective?
2. High temperature limit thermostat. (Manual reset)
3. Not properly set.

If lamp #12 does not light, check:

1. Is lamp #12 getting power or is the bulb defective?
2. Airflow switch adjustment
3. Dirty filters or loose belts.

If lamps #13 & #14 do not light, check:

1. Are lamps #13 and #14 getting power or are the bulbs defective?
2. Reset button on the RM7890 flame relay.
3. Connection of the wire #13 to terminal 10 on the flame relay and wire #14 to terminal 8.
4. C7027A flame sensor. Remove from the sighting tube and observe UV tube during new sequence. If it lights (bright orange) or flickers when fan starts, it is defective. (Replace) It should flicker when it sees a flame. If it glows solid, replace.
5. If it does not flicker occasionally or light, replace the RM7890.

NOTICE

#13 and #14 come on at the same time. #13 will go out after flame is proven. #14 will stay on for the ten second flame establishing period. #15 is energized when #13 is turned off.

If lamp #15 does not light, check:

1. Is lamp #15 getting power or is the bulb defective?
2. Are the valves opening and staying open?
3. Is the flame light on the flame relay coming on? The flame being proven during PFEP.
4. See check out procedure for C7027A sensor under #13 & #14.

If lamp #16 does not light, check:

1. Is lamp #16 getting power or is the bulb defective?
2. Operation of safety shut-off valve.
3. Auxiliary switch in the safety shut-off valve.

NOTICE

If all lights come on for approximately one minute, then #14, #15, and #16 go out, followed by a shutdown in 15 seconds, check flow of gas through valves to burner, and also burner port openings.

When unit has been checked, turn the circuit analyzer off. These are 20,000 hour neon lamps and should last the life of the equipment, unless the analyzer is left on after use.

NUISANCE SHUTDOWNS

Occasionally the unit may shut down during normal operation. Simply by turning the selector switch to the "off" position for 30 seconds, then back to "Winter", the unit will start again through a complete cycle and run normally. This condition could be caused by one of the following:

1. Momentary Loss of Power
2. Low Temperature Limit
3. Airflow Switch

EXAMPLE: Low limit opens during operation or remains open on initial start up due to insufficient heat. Manually reset the unit by turning the selector switch to “OFF”, then back “ON”. All other controls will require manual reset at the control, except the airflow switch.

Notes:

- Usually nuisance shut downs are one of two things:
- a) Low temperature limit: The unit shuts down as soon as the reset timer times out.
 - b) Air Flow Switch: Typically these are periodic shut downs and do not happen predictably.

FOR TROUBLE SHOOTING TEMPERATURE CONTROLS CONSULT THE MAXITROL BULLETIN FOUND AT WWW.MAXITROL.COM.

Annual Maintenance Recommendations

MAINTENANCE SCHEDULING

Prior to heating season each year, the following inspections and tests should be made to be sure the unit is in proper operating condition for the heating season.

Turn off power at the main disconnect switch. Examine the inside of the air make-up unit. See that the thermostat and temperature sensing elements are in place and their support brackets are solid. Examine the damper blades and linkage to insure that they have not been damaged. Turn the propeller by hand to be sure the bearings turn freely with no rough spots or noise. Be sure the grease lines and fittings are intact. Check the velocity monitor to be sure the venturi and the tubing to the airflow switch are not obstructed.

BLOWER ASSEMBLY

The blower assembly includes the fan bearings, drive sheaves and belts.

Bearings should be checked for any unusual wear and replaced if needed. Also make sure bearings are secure and locking collars tight.

Check the belt drive for proper tightness and alignment. If belts are beginning to wear, replace them. If the sheaves show signs of wear in the grooves, replace both fan and motor sheaves and the belts. **(New belts should be retightened after 24 hours of operating and again after a week’s operation.)**

LUBRICATION INSTRUCTIONS FOR FANS AND BLOWERS

Bearings and grease lines on fans are lubricated on assembly. When lubrication is required, add grease slowly while shaft is rotating until grease comes rapidly out of the relief port on the fitting. For extreme conditions lubricate according to experience. Check lubrication table in Aerovent IM-100 for frequency recommendations.

LUBRICATING DOOR HINGES

Door hinges should be lubricated on a monthly basis even though they are stainless steel to keep hinges from “freezing up” due to lack of use. Apply oil at the hinge and work the oil in by opening and closing the door several times.

LUBRICATION INSTRUCTIONS FOR MOTOR

Grease lubricated bearings as furnished are adequate for a long period of operation without relubrication. A good maintenance schedule for regreasing will vary depending on motor size, speed, duty and environment. See lubrication table in IM-100.

The table suggests relubrication intervals for motors on normal, steady running, light duty indoor loads in relatively clean atmosphere at 40° C (105° F) ambient temperature or less. Motors with no provision for lubrication are equipped with sealed bearings and require no maintenance. Motors mounted in inaccessible locations are provided with extended grease lines to facilitate lubrication. They are equipped with relief fittings to prevent overlubrication. The grease lines are filled with lubricant at the factory.

SERVICE INSTRUCTIONS FOR FILTERS

If the unit is supplied with a dirty filter switch and light, clean or replace the filters any time the dirty filter light comes on.

Units which do not have a dirty filter warning light should have the filters checked monthly. Clean or replace if necessary. In dirty atmospheres, filter maintenance may be required more often.

SERVICE INSTRUCTIONS FOR BURNERS

Generally, direct-fired burners tend to be self cleaning, however, if the unit is installed in a severely dirty environment a periodic cleaning of the burner may be required.

Depending on the size of the burner it may not be practical to attempt to remove the burner from the unit. The burner can still be cleaned by using the following steps:

1. Turn off gas and power. Remove the pilot and igniter assembly from burner.
2. Break the gas union at the burner and isolate the burner piping from the manifold piping.
3. Seal the open end of the manifold piping with duct tape or other means to prevent dirt from entering the manifold pipe and/or gas controls.
4. Using a high pressure air hose (40 to 80 psi) flush the burner gas ports from the flame side of the burner. Continue flushing until dust particles are removed.

NOTICE
If air pressure alone is not sufficient to clean the burner gas ports, the ports may be cleaned by using the appropriately sized drill from a numbered drill set.

Consult Maxon literature at www.maxoncorp.com for the proper bit. NP-LE burners require different bits than that of an NP (#47). See Figure 20.

When using a drill to clean the burner gas ports, be careful not to distort or enlarge the ports.



5. Examine the stainless steel mixing plates carefully. They should be clean and not warped or cracked. It is especially important to make sure the mixing plates nearest to the burner manifold are clear. Mixing plates can be cleaned with compressed air or wire brush.
6. Remove the protective cover, which was placed on the manifold piping in Step 3, and reconnect the gas union.
7. Reassemble pilot and igniter assembly to the burner.
8. After cleaning and reassembly, use a soap/water solution to check for gas leaks in the piping.
9. Restore power and gas to the unit. Reset pressure switches.
10. Run the fan in the "Summer" position to see that the damper is opening and closing properly. Be sure that the gas is on and the proper pressure is indicated. Turn the unit on in the "Winter" position and observe its operation on the circuit analyzer. (If it is a warm day, it will be necessary to increase the setting of the mild weather thermostat in order to get the unit to fire.) Watch the burner when it first lights. It should light off with a low flame, then increase in size and stabilize out somewhere in between. This would

indicate that the modulating system is working.

11. If you have cleaned the burner plates or if the burner plates are dusty, there will be a lot of color in the flame and luminous particles will be present. These will disappear after the burner operates for a while.

If the unit fails to operate, refer to the section on trouble shooting and analyze the problem. After you are satisfied with the checkout, be sure to set the mild weather control to the desired heat-off temperature. This is usually 60° to 65°.

GAS AND ELECTRIC CONTROLS

Inspect for general cleanliness and tightness of electric and mechanical connections. Check gas valves a minimum of once per year for tightness of the safety shut-off valves using the leak test ports on the valves

CARE OF HEATER FOR EXTENDED SHUTDOWN PERIODS

If the unit is to be shut down for an extended period of time, the following precautions should be followed.

1. Turn off all manual shutoff valve(s) at the unit, and in the gas supply line to the unit.
2. Turn off the electrical supply to the unit at the unit's disconnect. Lock the disconnect to prevent tampering.
3. If the unit is supplied with filters, remove and store filters.
4. Protect outside air opening to prevent the unit from being soiled.
5. Rotate prop/wheel monthly to lubricate bearings in the fan/blower and motor.

Figure 20.

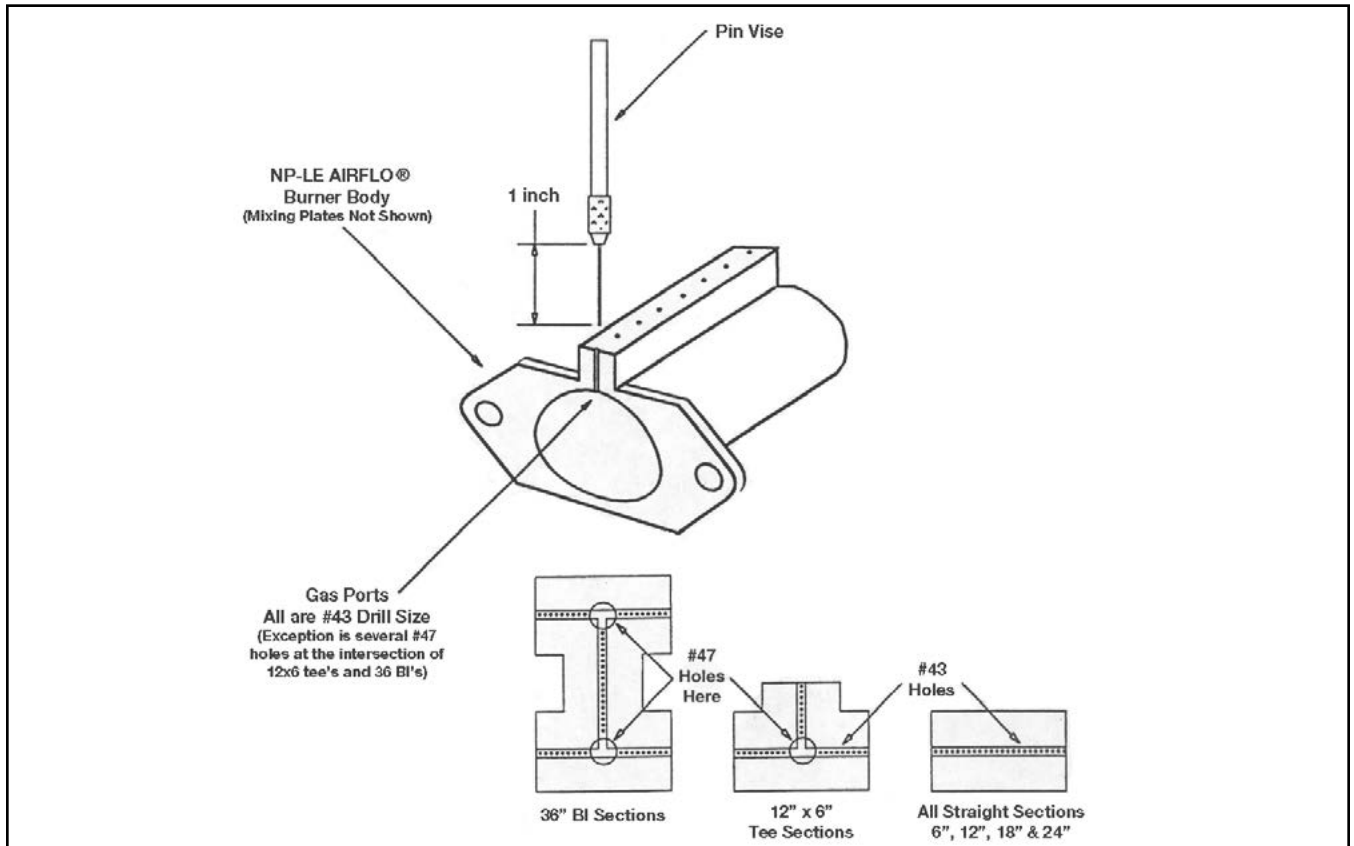

TERMS AND CONDITIONS OF SALE

1. AGREEMENT AND ACCEPTANCE. The terms and conditions set forth in this Agreement shall constitute the entire agreement between Twin City Fan Companies, Ltd. doing business as Aerovent (Seller) and Buyer and supersede all other agreements and understandings, whether written or oral, between the parties with respect to the subject matter hereof. Seller's acceptance of any offer by Buyer is expressly made conditional upon Buyer's assent to the terms and conditions hereof, and none of Buyer's additional or different terms shall apply. Acceptance of Seller's offer to sell is expressly limited to acceptance of the terms and conditions hereof, and no other terms or conditions shall apply, unless expressly agreed to by Seller by writing.

2. PRICE. All prices exclude federal, state, or local taxes, customs, duties, charges, consular fees, permit and license fees and any other taxes, fees or expenses which shall be added to the price or billed separately to Buyer where Seller has the legal obligation to collect or pay such taxes, fees, or expenses. All such taxes shall be paid by Buyer. Prices quoted are firm for thirty (30) days unless extended in writing by Seller. Prices are firm provided release to manufacturing and shipment is completed by Seller within one hundred and twenty (120) days of receipt of purchase order from Buyer. However, prices may increase as a result of delays due to changes requested by Buyer or Buyer's failure to furnish information requested. Seller reserves the right to change this policy at any time without written notice. Seller reserves the right to charge at any time a monthly service charge of one and one-half percent (1.5%) or the highest rate allowed by Law, whichever is lower, on accounts outstanding more than thirty (30) days from the date of Seller's invoice, effective as of the thirty-first (31st) day from the date of the invoice.

3. PAYMENT TERMS. If Seller has extended credit to Buyer (as evidenced by notation to that effect on the face of this Agreement), payment shall be due net thirty (30) days after date of Seller's invoice. The amount of credit may be changed and/or credit withdrawn by Seller, at any time. On any order on which credit is not extended by Seller, shipment or delivery shall only be made at Seller's election after payment in cash with order (in whole or in part), C.O.D., or by a sight draft upon presentation of bill of lading or other appropriate shipping documents covering each shipment. All costs of collection shall be borne by Buyer. If shipment or delivery is delayed by Buyer, payment shall be due when Seller is ready to make the shipment or delivery. Unless otherwise set forth on the face of the Agreement, all payments shall be made in U.S. Dollars. If Buyer fails to fulfill the terms of payment or if Seller shall have any doubt at any time as to Buyer's financial condition, Seller may decline to make further deliveries except upon prompt receipt of cash or satisfactory security, as decided by Seller. This requirement will not release Buyer from any previous obligation. Seller's right under this Section shall be in addition to all other rights and remedies available to Seller upon Buyer's default. In addition, if reasonably requested by Seller, Buyer shall establish an irrevocable letter of credit in favor of Seller, in an amount sufficient to cover the price of products and all related expenses which are for Buyer's account, and which includes such other terms and conditions and issued or confirmed by a U.S. bank, as may be acceptable to Seller.

4. ORDERS. No order shall be valid until accepted by Seller at its office in Minneapolis, Minnesota. U.S.A.

5. FORCE MAJEURE. Seller shall not be liable for any delays in the delivery of orders or any other failure to perform, due in whole or in part, directly or indirectly, to fire, storm, flood, earthquake, war, insurrection, labor disputes or shortages, act of God, strike, shortage of raw materials, supplies or components, retooling, upgrading of technology, delays of carriers, embargo, government order or directive, or any other circumstance beyond Seller's reasonable control. Buyer agrees that Seller shall not be liable for any direct, indirect, consequential, or special damages that may result from any such delays.

6. DELIVERY TERMS; RISK OF LOSS. Unless otherwise agreed to in writing by the Seller, all deliveries shall be F.O.B. Seller's factory. Seller will attempt to meet the requirements of Buyer's delivery schedule but shall be obligated only to the delivery schedule shown on the order acknowledgment and Seller shall not be in default of performance due to a delay of reasonable duration resulting from any cause. All delivery expenses, including transportation, freight, insurance, and any other shipping costs, and risk of loss during delivery and transportation, shall be for the account of Buyer. Claims for damages in transit must be assessed against the carrier. Unless otherwise instructed, selection of carrier and routing of all shipments shall be at Seller's discretion. All boxing and packaging charges for sales shall be added to the price. When special packaging is specified for domestic or export sales involving greater expense than that customarily supplied, a charge may be made to cover such extra expense. Shipment dates for export sales are approximate and are subject to receipt of all necessary Buyer information, letter of credit, if required, and all necessary licenses, permits and other documents.

7. INSPECTION AND ACCEPTANCE. Buyer must inspect delivered products and report claims for damages or shortages in writing within ten (10) days of delivery or the products shall be deemed irrevocably accepted and such claims be deemed waived.

8. LIMITED WARRANTY AND REMEDIES. Seller warrants to the original purchaser that the products sold hereunder shall be free from defects in workmanship and material upon delivery under normal use and service (except in those cases where the materials are supplied by Buyer). The liability of Seller under this warranty is limited to replacing, repairing, or issuing credit (at cost, FOB factory and at Seller's discretion) for any part or parts which are returned by Buyer within one year from the date of original installation or eighteen (18) months from the date of shipment, whichever occurs first provided that (a) Seller is notified in writing within ten (10) days following discovery of such defects by Buyer, or within ten (10) days after such defects should reasonably have been discovered, whichever is less, (b) the defective unit is returned to Seller, transportation charges prepaid by Buyer, (c) payment in full has been received by Seller for said products, (d) Seller's examination of such unit shall disclose to its satisfaction that such defects have been caused by misuse, neglect, improper installation, repair, unauthorized modification, Buyer's design, alteration, act of God, or accident. No warranty made hereunder shall extend to any Seller's product whose serial number is altered, effaced or removed. Seller makes no warranty, expressed or implied with respect to the specific application which Seller's products are used or the design or operation of an entire system in which Seller's products sold hereunder are mere components, nor does Seller make any warranty, expressed or implied, with respect to motors, switches, controls, or other components of Seller's product where such components are warranted separately by their respective manufacturers. Repair or replacement of the products sold hereunder, or refund of the purchase price as provided in this warranty, is the Buyer's exclusive remedy. This exclusive remedy will not be deemed to have failed its essential purpose so long as Seller is willing and able to repair or replace any defective product or refund the purchase price, in the prescribed manner. THIS WARRANTY IS EXPRESSLY IN LIEU OF ALL OTHER WARRANTIES, EXPRESSED OR IMPLIED, WHETHER STATUTORY OR OTHERWISE, INCLUDING ANY WARRANTY OF MERCHANTABILITY, INFRINGEMENT, OR FITNESS FOR A PARTICULAR PURPOSE. BUYER'S FAILURE TO PAY THE FULL AMOUNT DUE WITHIN SIXTY (60) DAYS OF DATE OF INVOICE SHALL OPERATE TO RELEASE SELLER FROM ANY AND ALL LIABILITY OR OBLIGATION ARISING PURSUANT TO ANY WARRANTY, EXPRESSED OR IMPLIED, WHETHER STATUTORY OR OTHERWISE, INCLUDING ANY WARRANTY OF MERCHANTABILITY, INFRINGEMENT, OR FITNESS FOR A PARTICULAR PURPOSE, MADE IN CONNECTION WITH ANY CONTRACT FORMED HEREUNDER. BUYER AGREES THAT SUCH FAILURE TO PAY SHALL CONSTITUTE A VOLUNTARY WAIVER OF ANY AND ALL SUCH WARRANTIES ARISING PURSUANT TO SUCH CONTRACT. Seller makes no other warranties of any kind and any repair or attempt to repair products by anyone other than an authorized representative of Seller automatically voids any warranty of those products. Any oral or written statement concerning the products inconsistent with the warranty contained herein shall be of no force or effect.

9. LIMITATIONS ON LIABILITY. Under no circumstances shall Seller be liable for any indirect, consequential, collateral, special or incidental damages (including without limitation, increased manufacturing costs, loss of profits, or goodwill) whether such claim is based on contract, negligence, strict tort, warranty or any other basis. Seller's liability shall in no event exceed the purchase price of the particular products with respect to which a claim is made. Tools, dies, and other equipment furnished to Seller by Buyer shall be at Buyer's risk and expense. Seller does not insure Buyer under any of its insurance policies, including liability or workers' compensation. Seller will not provide Buyer with indemnification for any matter nor does Seller agree to provide Buyer with contribution for any damages. Seller has no obligation to Buyer to direct Seller's insurance companies to waive their right of subrogation against Buyer in the event of an insured loss.

10. LIMITATION OF ACTIONS. Any actions or claims by Buyer under this Agreement shall be brought within 18 months after shipment of the products sold by Seller hereunder.

11. PATENTS. When Seller has manufactured any products or parts thereof in accordance with specifications or drawings furnished by Buyer or when a product or a part thereof is made to Buyer's design, Buyer at its own expense will defend any suit against Seller for infringement of patents and will satisfy any final award of damages for such infringement; provided Seller gives Buyer notice in writing of any such suit for infringement, opportunity to conduct the defense thereof and assistance and cooperation in said defense. As to other articles furnished by Seller, Seller, at its own expense will defend any suit against Buyer for infringement of United States patents by any such product purchased from Seller when used or sold for its normal purpose and in any such suit will satisfy any final award of damages for such infringement, but Seller assumes no liability, consequential or otherwise, for infringement or patent claims covering any components, switches, motors or other parts purchased by Seller from third parties or covering any other product, or any completed equipment, or any assembly, combination, method of process, in which, or in the manufacture or testing of which, any such product may be used (notwithstanding that such product may have been designed only for use in, or may be useful in, such other patented product or such patented equipment, assembly, combination, method or process, or in the manufacturing or testing thereof, and that such product may have been purchased by Buyer and sold by Seller for such use.) This covenant by Seller is upon the condition that Buyer shall give Seller a prompt notice in writing of such suit or infringement, full opportunity to conduct the defense thereof and full assistance and cooperation in said defense. No cost or expense shall be incurred for the account of

Seller without its written consent. When Buyer orders articles Buyer is licensed to have made for Buyer, Seller is hereby authorized to manufacture said articles under Buyer's license and Buyer will be responsible for such royalties as may be due and for such notification to its licensor as Buyer is obligated to make.

12. CHANGES. After acceptance by Seller, Buyer's order shall not be subject to cancellation, change or reduction in amount nor to any suspension by Buyer of deliveries without Seller's prior written consent. Buyer acknowledges that Seller engages in continuous product improvement and makes changes to its products from time to time. The Seller reserves the right to make reasonable changes and use substitute parts or products as long as such substitutions perform equal or better than the original product or part thereof, and shall have the right to deliver revised designs or models and such substitute products or parts against any order.

13. NONWAIVER OF DEFAULT. Each shipment made under any order shall be treated as a separate transaction, but in the event of any default by Buyer, Seller may decline to make further shipments without in any way affecting its rights under such order. If, despite any default by Buyer, Seller elects to continue to make shipments, its actions shall not constitute a waiver of any default by Buyer or in any way affect Seller's legal remedy for such default, Seller's failure to deliver, or nonconformity of, any installment of this Agreement shall not be a breach of the entire Agreement.

14. TERMINATION. If the products to be furnished under this order are to be used in the performance of a Government contract or subcontract and the Government terminates such contract, in whole or in part, this order may be cancelled in the same proportion, and the liability of Buyer for termination allowances shall be determined by the then applicable regulations of the Government regarding termination of contracts. No termination by Buyer for default shall be effective unless Seller shall have failed to correct such alleged defect within fifteen (15) days after receipt by Seller of a written notice specifying such default.

15. ASSIGNS. This agreement shall be binding and shall inure to the benefit of the successors and assigns of the entire business and good will of either Seller or Buyer or of that part of the business of either used in the performance of this Agreement, but shall not be otherwise assignable.

16. MODIFICATION OF STANDARD TERMS AND CONDITIONS. No addition to or modification of any of the provisions upon the face or reverse of this form shall be binding upon Seller, unless made in writing and signed by a duly authorized employee of Seller.

17. ARBITRATION. Buyer agrees that all claims, demands, disputes, controversies, and differences arising under any contract made hereunder shall be settled exclusively in arbitration in accordance with the rules then prevailing of the American Arbitration Association. Upon prevailing in any such arbitration, Seller shall be entitled to an award of its costs and attorneys fees. Judgment on the award thus rendered shall be binding on the Buyer and may be entered in any court having jurisdiction thereof. Unless the parties agree otherwise in writing, such arbitration will be conducted in Minneapolis, Minnesota, U.S.A.

18. EXPORT REGULATIONS; PERMITS. Buyer will comply with the provisions of the United States Government's Export Administration regulations and related documentation requirements and internal control procedures. Buyer shall be responsible for obtaining any necessary export or import licenses and permits.

19. APPLICABLE LAW. This agreement shall be governed by and construed in accordance with the internal laws (and not the laws of conflicts) of the State of Minnesota, U.S.A. and the Buyer submits to the personal jurisdiction of courts located in Minnesota, U.S.A. The United Nations Convention on Contracts for the International Sale of Products shall not apply to this Agreement.

20. VALIDITY. If any provision of this Agreement is found to be invalid or unenforceable in any respect, the validity and enforceability of the remaining provisions shall not be affected.

21. MISCELLANEOUS. All clerical errors are subject to correction. Seller may subcontract the furnishing of any products sold hereunder and any portion thereof.

Aerovent

800 S. High St., Covington, OH 45318
Phone: (937) 473-3788 Fax: (937) 473-3793

DIRECT GAS FIRED AIR MAKE-UP START-UP REPORT, INSTALLATION & MAINTENANCE

Job Name: _____ Date: _____
Address: _____ Model No: _____
City & State: _____ Order No: _____
Serial No: _____



WARNING

BEFORE STARTING UP AIR MAKE-UP UNIT READ SAFETY INSTRUCTIONS OF THE MANUAL TO ENSURE THAT YOU OR ANY PERSONNEL AT THE INSTALLATION SITE ARE NOT EXPOSED TO AN UNSAFE OPERATING CONDITION WHICH COULD BE DETRIMENTAL TO THEIR SAFETY.

NOTICE

All units were test run and fired at the factory. The following steps assure no damage occurred in shipment.

- ___ 1. Any visible shipping damage to unit. Describe:
- ___ 2. All shipping straps, braces, tie downs removed.
- ___ 3. Unit installed level and secure.
- ___ 4. All seams properly caulked where unit was assembled in two or more sections.
- ___ 5. All filters installed in racks properly with airflow in proper direction.
- ___ 6. Bolts on taper lock bushings securing wheel and drive sheaves have been checked to be sure that they are tight.
- ___ 7. Bolts on motors and bearings have been checked to be sure that they are tight and drives are properly aligned.
- ___ 8. Bearings checked for proper lubrication.
- ___ 9. Belt tension checked.
- ___ 10. Rotate wheel to make sure nothing is rubbing and bearings, allow to rotate without binding.
- ___ 11. Check air inlet and discharge areas for debris which could be drawn into fan wheel or blown into discharge area.
- ___ 12. Check all electrical wiring to be sure connections are tight and are making good contact.
- ___ 13. Blow out all new supply piping lines with air before connecting to the pipe train to be sure they are free from foreign materials that could prevent proper seating of safety shut off valves **(strainers are suggested)**.
- ___ 14. Bleed gas supply line of air before starting unit. Reference ANSI procedures Z223.1, latest edition. (Unit will lock out on safe shut down until raw gas reaches the gas train and pilot lights off.)

- ___ 15. Gas supply to unit: ___ Natural ___ Propane
Gas supply pressure to unit: ___" w.c. ___ psig
- ___ 16. Mount UV sensor on sighting tube (shipped loose to prevent damage).
- ___ 17. Check gas supply pressure at manifold and compare to gauge marking (max pressure 5 psi).
- ___ 18. Check all piping including internal to burner for gas leaks with soapy water test.
- ___ 19. Pressure regulators and vent valves are vented to outside area (installing contractor responsibility on inside units).
- ___ 20. Check to be sure manual resets on gas pressure switches have been manually reset and set point are correct.
- ___ 21. Electric supply to unit: ___ Volts ___ Hz ___ Phase. Verify that motor name plate and control panel agree with supply voltage, phase, and hertz.
- ___ 22. Make sure all hand gas shut-off cocks are **in closed position**.
- ___ 23. Energize main control panel by engaging main disconnect.
- ___ 24. Set selector switch to summer and turn start switch to on position. When starter kicks in after damper opens, turn off immediately and check to see if blower wheel is rotating in correct direction.
- ___ 25. Inlet and/or discharge dampers operating correctly with no binding?
- ___ 26. Blower speed: Hi Speed ___ RPM, Lo Speed ___ RPM
- ___ 27. Motor speed: Hi Speed ___ RPM, Lo Speed ___ RPM
- ___ 28. Is unit excessively noisy? ___ Dba
- ___ 29. Motor voltage: L1 ___ V, L2 ___ V, L3 ___ V
- ___ 30. Motor amps: High Speed L1 ___ Amp, L2 ___ Amp, L3 ___ Amp
Low Speed L1 ___ Amp, L2 ___ Amp, L3 ___ Amp
- ___ 31. Is there excessive vibration? ___ Yes ___ No
CONTACT FACTORY IF "YES"
- ___ 32. Switch selector to winter position and open manual shut-off cocks to main gas and pilot lines.
- ___ 33. Pilot sensor volts: ___ UV (Volts D.C. 1.25 to 5 Volts D.C.). Measure at RM7895 relay terminals.
- ___ 34. Burner observation and adjustments. Reference Maxitrol operating description on page 11.
Adj. Hi Fire: Burner pressure reading ___" w.c.
Adj. Lo Fire: Does entire burner exhibit flame?
___ Yes ___ No
Is flame clean and stable? ___ Yes ___ No
Review Maxitrol bulletin for adj. high and low fire

- ___ 35. Flame safeguard functioning correctly.
Time required to go into lockout: ___ Seconds
- 36. Mild weather control cycled and reset to proper setting (65° F)
- 37. Air flow proving switch cycled for functionality by blocking off 1/3 of system inlet.
- 38. High temperature limit control cycled for test by lowering set point checked for functionality required manual reset.
- 39. Low temperature limit & timer. Set low limit above the ambient temperature. Set timer to 1 minute. Unit should shut down after timer times out. After shut down reset timer to 3 minutes. Reset unit and restart.
- 40. Does flame modulate in response to temperature set point changes?
- 41. Recirculating Systems ONLY: Burner by-pass and return air damper operating correctly when setting changes on rheostat or static pressure sensing device dampers should modulate to new position and maintain stability.
- 42. Do all dampers return to closed position with power interruption? (On recirculation system return air open outside air closed.)

USE BACK OF REPORT FOR COMMENTS

DATE OF INSTALLATION _____

Name, address and phone number of company doing installation: _____

Technician Signature: _____

Date: _____

Return the start-up report to your sales representative to activate the warranty. The representative will then return the report to the factory. Please keep a copy for your records. Contact Aerovent at (937) 473-3788 if there are any questions.

DATE OF START-UP _____

Name and address of company doing start-up: _____

Technician Signature: _____

Date: _____

Return the start-up report to your sales representative to activate the warranty. The representative will then return the report to the factory. Please keep a copy for your records. Contact Aerovent at (937) 473-3788 if there are any questions.



AEROVENT | WWW.AEROVENT.COM

5959 Trenton Lane N | Minneapolis, MN 55442 | Phone: 763-551-7500 | Fax: 763-551-7501