

## Installation

1. Check for possible damage in shipment to roof ventilator.
2. Assemble stack cap section, fan and curb base.
3. Caulk between flanges of damper section, fan section and curb base (see illustration).
4. Install assembled ventilator onto roof curb. Secure ventilator to curb with bolts (see illustration).
5. Check propeller for proper rotation.
6. Make certain dampers operate smoothly and are free from obstruction.

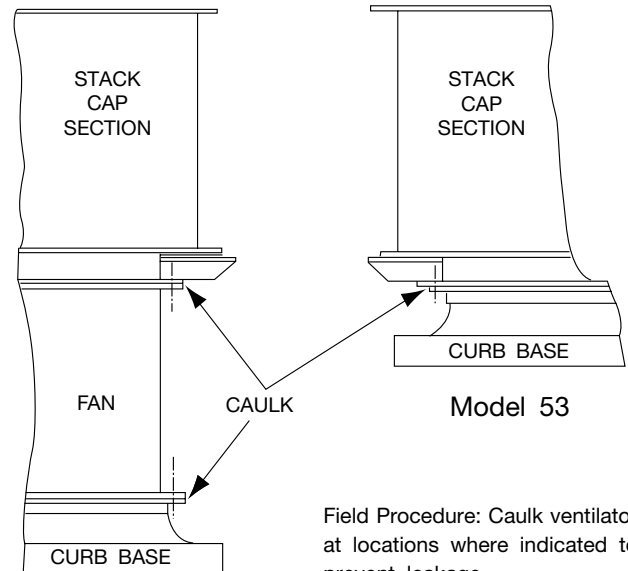

Field Procedure: Caulk ventilator at locations where indicated to prevent leakage.

Model 40C & SV40

### Detail of Mounting

#### Flat Type Curb Base on Existing Roof

Use Hydro Shield and heavy-duty glass membrane — Addex Corporation (or equal).

1. Set ventilator curb base in mastic.
2. Apply mastic over curb base flange.
3. Work membrane into mastic.
4. Trowel mastic over membrane and work in.

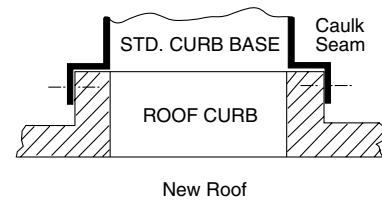
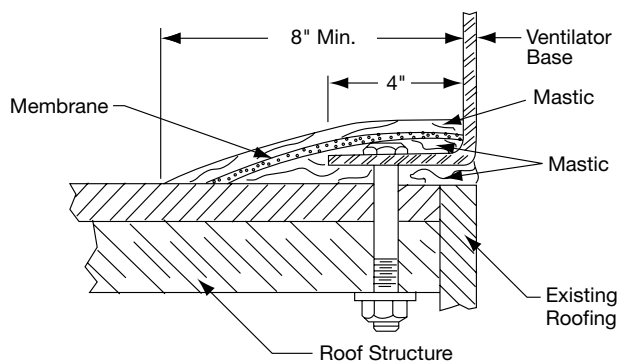

New Roof

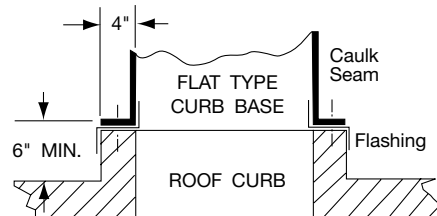

New Roof

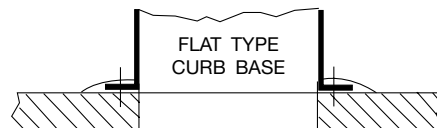

Existing Roof

## Care and Maintenance

Good fan maintenance requires regular and systematic inspection of all fan parts. Severity of the application should determine frequency of inspection.

Regular fan maintenance should include the following:

1. **Propeller** — The propeller in an axial flow fan must be kept reasonably clean if it is to perform properly. Fans handling fresh air for ventilating purposes will seldom need cleaning. Fans exhausting process air should be cleaned as required. Dirt or chemical deposits will usually build up on a propeller evenly, and they present no problem to performance or operation until they become thick enough to break away in crust-like pieces. When this happens, the propeller may be thrown out of balance and the resulting vibration could be serious. The dirt or chemical deposits should be removed by solvent cleaning or scraping. If the propeller has been coated, be careful not to cut through this protective covering. If the propeller shows excessive wear, it should be replaced immediately. Refer to General Installation and Maintenance IM-100 for proper procedure in removing and replacing the propeller.
2. **V-Belt Drive** — Check V-belt drive for proper alignment and tension. See General Installation and Maintenance IM-101 for instructions.
3. **Fan Bearings** — Lubricate the bearings (if belt driven). Bearing lubrication instructions are detailed in IM-100.
4. **Screws and Bolts** — Check tightness of all screws and bolts throughout the ventilator assembly.
5. **Stack Cap** — Periodically check damper blades and remove accumulated dirt. Check bronze damper bearings for smooth operation.



---

**AEROVENT | WWW.AEROVENT.COM**

**5959 Trenton Lane N | Minneapolis, MN 55442 | Phone: 763-551-7500 | Fax: 763-551-7501**