

General Installation, Operation and Maintenance Instructions For Aerovent Products

The Tu-WAY™ Roof Ventilator is specifically designed for either exhaust or supply. The assembly consists of a hood and base with the fan being an integral part of the base. The unit is constructed to allow the hood to be raised for easy access to propeller and motor. An access door in the base provides a convenient method of servicing the shutter.

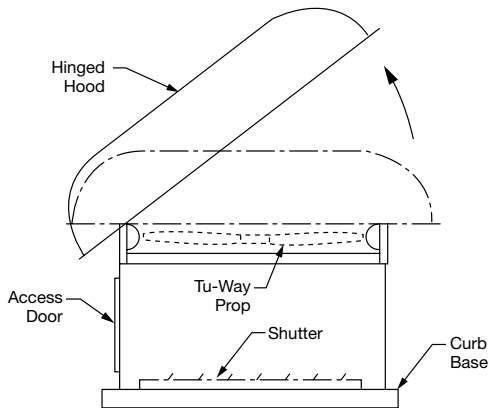

Suggested Mounting For Curb and Flat Type Bases

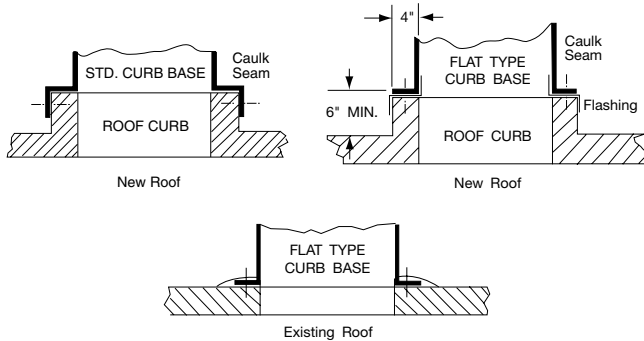

Detail of Mounting Flat Type Curb Base on Existing Roof

Use Hydro Shield and heavy-duty glass membrane — Addex Corporation (or equal).

1. Set ventilator curb base in mastic.
2. Apply mastic over curb base flange.
3. Work membrane into mastic.
4. Trowel mastic over membrane and work in.

Care and Maintenance

Good fan maintenance requires regular and systematic inspection of all fan parts. Severity of the application should determine frequency of inspection.

Regular fan maintenance should include the following:

1. **Propeller** — The propeller in an axial flow fan must be kept reasonably clean if it is to perform properly. Fans handling fresh air for ventilating purposes will seldom need cleaning. Fans exhausting process air should be cleaned as required. Dirt or chemical deposits will usually build up on a propeller evenly, and they present no problem to performance or operation until they become thick enough to break away in crust-like pieces. When this happens, the propeller may be thrown out of balance and the resulting vibration could be serious. The dirt or chemical deposits should be removed by solvent cleaning or scraping. If the propeller has been coated, be careful not to cut through this protective covering.
2. **V-Belt Drive** — Check V-belt drive for proper alignment and tension. See General Installation and Maintenance IM-100 for instructions.
3. **Fan and Motor Bearings** — Lubricate the bearings (if belt driven). Bearing lubrication instructions are detailed in IM-100.
4. **Shutters** — Periodically check damper blades and remove dirt accumulation. Bronze damper bearings should be checked for smooth operation.
5. **Screws and Bolts** — Check for tightness throughout the assembly.

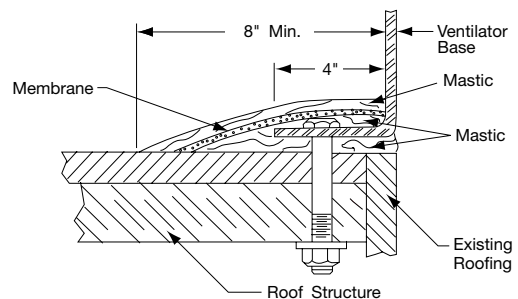

Wiring Diagrams For Tu-WAY™ Roof Ventilator Single Phase Motor

Single Voltage Motors or Low Voltage Connections on Dual Voltage Motors

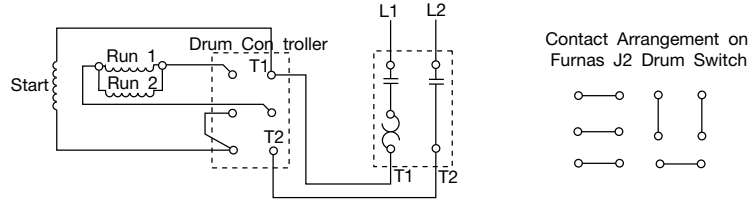

Manual or Magnetic Starter With Reversing Drum Controller (Furnas J3 or Equal)

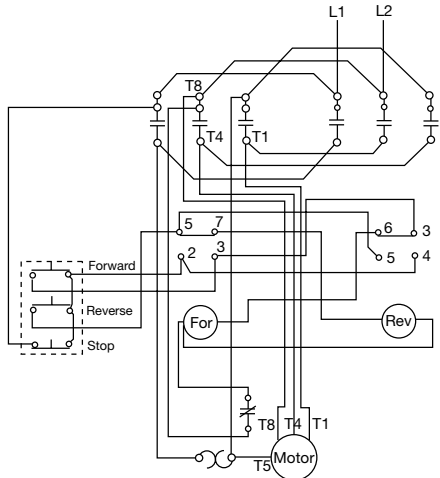

3-Pole Magnetic Reversing Starter
(Allen Bradley Bulletin 705 or equal)

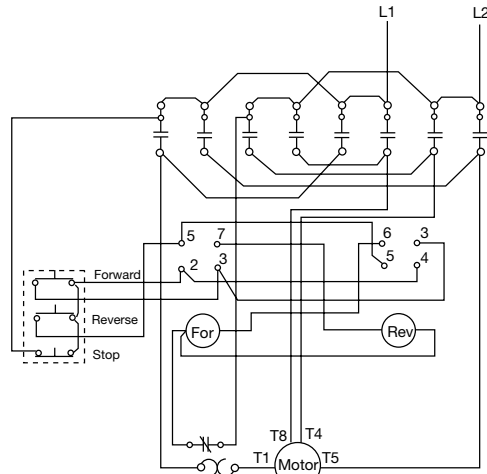

4-Pole Magnetic Reversing Starter
(Allen Bradley Bulletin 705 or equal)

High Voltage Connections on Dual Voltage Motors

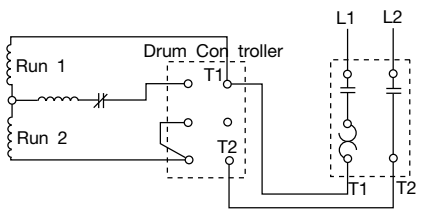

Manual or Magnetic Starter With Reversing
Drum Controller (Furnas J2 or equal)

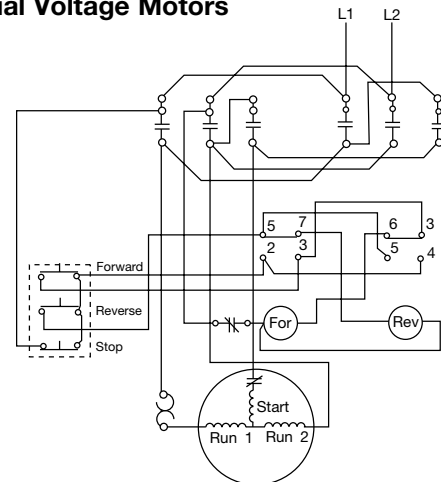

3-Pole Magnetic Reversing Shutter
(Allen Bradley Bulletin 705 or equal)

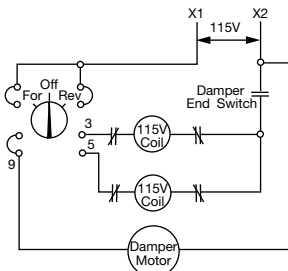

For use with motorized damper
and magnetic reversing starter
or 2-speed stator with reversing
drum controller.

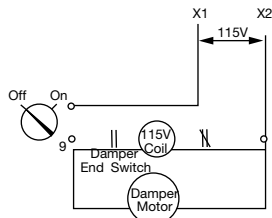

For use with motorized
damper and magnetic starter
with reversing drum controller.

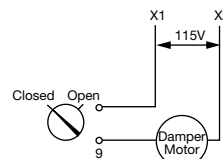

For use with complete manual
starter systems and motorized
dampers. Open damper fully
before energizing fan.

Wiring Diagrams For Tu-WAY™ Roof Ventilator Three Phase Motor

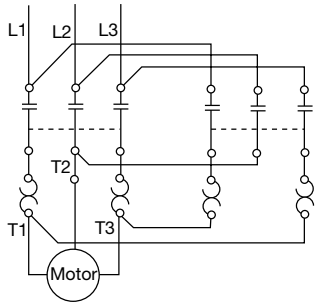

Manual Reversing Starter
(Allen Bradley Bulletin 609RS or equal)

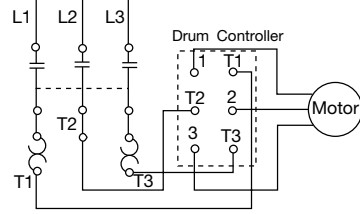
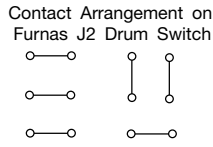

Manual or Magnetic Starter With
Reversing Drum Switch (Furnas J2 or equal)

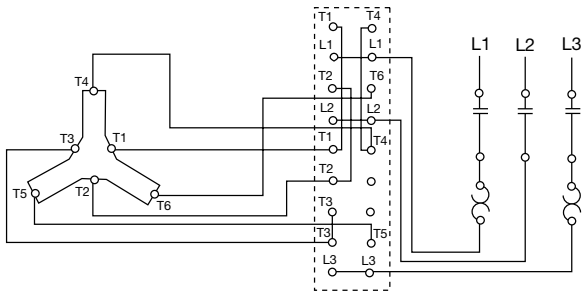

Manual or Magnetic Starter With 2-Speed Reversing
Drum Switch (Single Winding Motor)

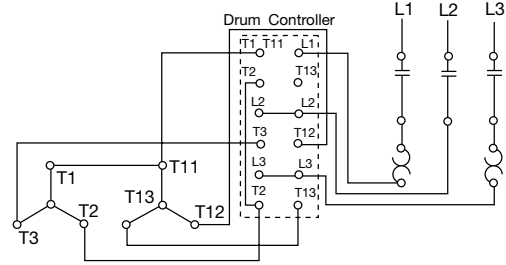

Manual or Magnetic Starter With 2-Speed Reversing
Drum Switch (2-Winding Motor)

SPEED	L1	L2	L3	TOGETHER
Low Forward	T1	T2	T3	
High Forward	T6	T4	T5	T1-T2-T3
Low Reverse	T2	T1	T3	
High Reverse	T4	T6	T5	T1-T2-T3

SPEED	L1	L2	L3
Low Forward	T1-T11	T2	T3
High Forward	T1-T11	T12	T13
Low Reverse	T1-T11	T3	T2
High Reverse	T1-T11	T13	T12

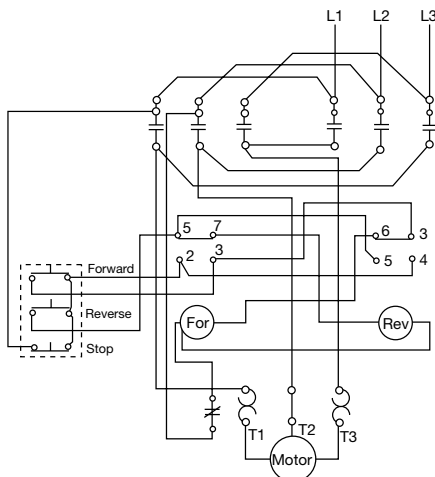

Magnetic Reversing Switch

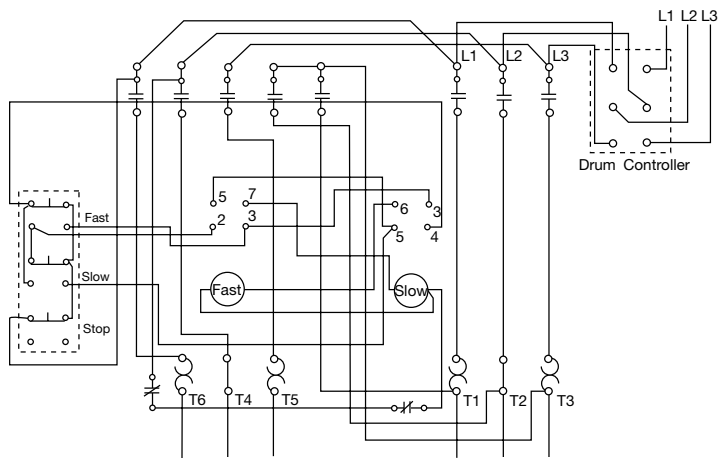

Reversing Drum Switch With 2-Speed Magnetic
Starter (Consequent Pole Motors)

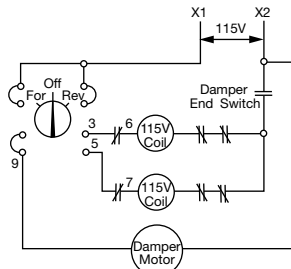
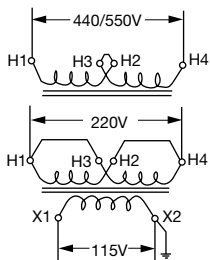

For use with motorized damper and magnetic
reversing starter or 2-speed stater with reversing
drum controller.

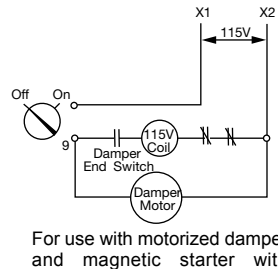

For use with motorized damper
and magnetic starter with
reversing drum controller.

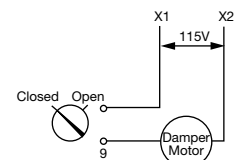

For use with complete manual
starter systems and motorized
dampers. Open damper fully
before energizing fan.

Wiring — Disconnect Switch, Starter and Fan Motor

3-Pole Disconnect Switch/2 Speed Motor

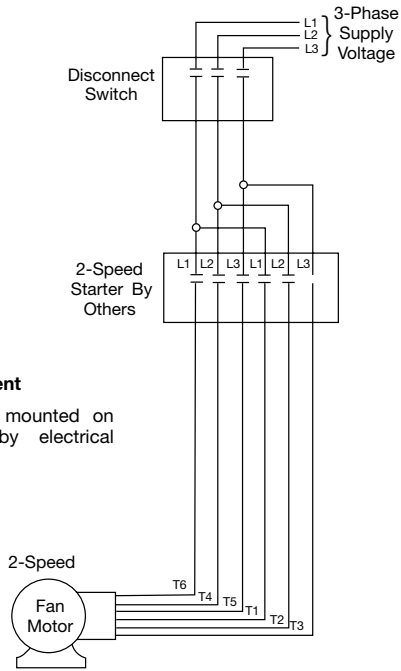

Optional By Aerovent
Disconnect switch mounted on unit. All wiring by electrical contractor.

6-Pole Disconnect Switch/2-Speed Motor

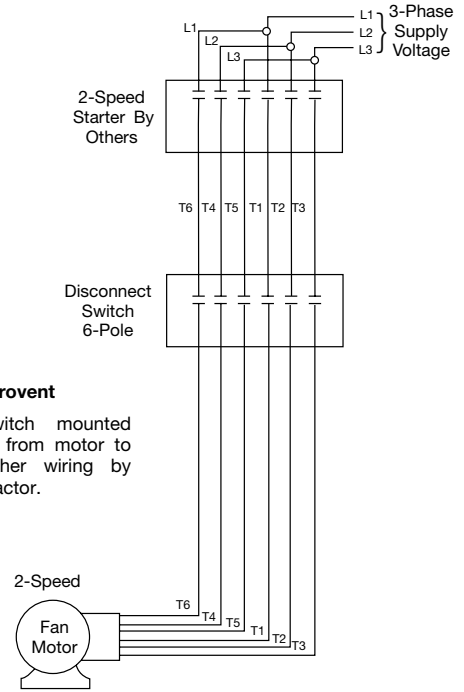

Optional By Aerovent
Disconnect switch mounted on unit. Wiring from motor to disconnect. Other wiring by electrical contractor.

3-Pole Disconnect Switch/Single-Speed Motor

Optional By Aerovent
Disconnect switch mounted on unit. Wiring from motor to disconnect.

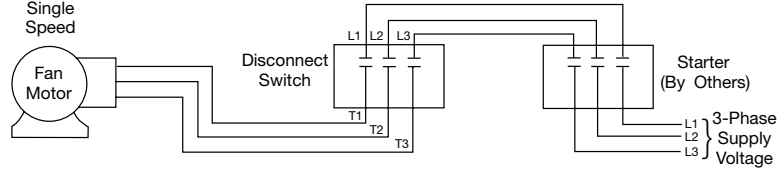

AEROVENT | WWW.AEROVENT.COM

5959 Trenton Lane N | Minneapolis, MN 55442 | Phone: 763-551-7500 | Fax: 763-551-7501