

REVIEW AMCA BULLETIN 410 PRIOR TO INSTALLATION

This bulletin has been prepared to guide the users of industrial centrifugal fans in the proper installation, operation and maintenance procedures to insure maximum equipment life with trouble-free operation. For safe installation, startup and operational life of this equipment, it is important that all involved with the equipment be well versed in proper fan safety practices and read this bulletin. It is the user's responsibility to make sure that all requirements of good safety practices and any applicable safety codes are strictly adhered to. Because of the wide variety of equipment covered in this bulletin, the instructions given here are general in nature. Additional product and engineering information is available at www.aerovent.com.

SAFETY NOTICE	
Refer to the safety section(s) in this manual prior to installing or servicing the fan. The most current version of this installation and maintenance manual can be found on our website at www.aerovent.com/resources/im-manuals .	

TABLE OF CONTENTS

Overview of Centrifugal Fan Arrangements.....	2	Motor Maintenance.....	16
Exploded Views.....	3	Drive Maintenance.....	16
Wheel Nomenclature.....	3	Fan Bearing Maintenance	17
Wheel Types & Wheel Rotation.....	4	Wheel and Shaft Maintenance.....	17
Safety & Hazard Warnings	5	Structural Maintenance.....	17
Shipping & Receiving.....	5	Duct Connections.....	17
Handling	6	Optional Accessories	18-21
Unit Storage.....	7	Grouting.....	22
Foundations and Supporting Structures.....	8	Serial Number & Fan Type Nameplate	22
Fan Installation, Factory Assembled Units.....	9	Wheel Placement / Wheel Overlap	23-26
Fan Installation, Disassembled Units with Split Housings ...	10-11	Troubleshooting Guidelines	27
Bearing Installation.....	12	Installation / Start-up Checklist	28
Safety & Bearing Lubrication Instructions	13	Fan Maintenance Log	29-31
Drive Mounting.....	14		
Flexible Couplings.....	15		
Maintenance	16		

CENTRIFUGAL FAN ARRANGEMENTS - SINGLE WIDTH, SINGLE INLET (SWSI)



ARRANGEMENT 1
Belt Driven or Direct Drive



ARRANGEMENT 3
Belt Driven



ARRANGEMENT 3F
Belt Driven



ARRANGEMENT 3SI
Belt Driven or Direct Drive



ARRANGEMENT 4
Direct Drive



ARRANGEMENT 4S
Direct Drive
(Swingout Door)



ARRANGEMENT 4VI
Direct Drive
(Vertical Inlet)



ARRANGEMENT 4HI
Direct Drive
(Horizontal Inlet)



ARRANGEMENT 7
Direct Drive



ARRANGEMENT 7SI
Direct Drive



ARRANGEMENT 8
Direct Drive



ARRANGEMENT 9
Belt Driven



ARRANGEMENT 9F
Belt Driven



ARRANGEMENT 9H
Belt Driven



ARRANGEMENT 9SS
Belt Driven
(Swingout Door)



ARRANGEMENT 9ST
Belt Driven
(Swingout Door)



ARRANGEMENT 10
Belt Driven

CENTRIFUGAL FAN ARRANGEMENTS - DOUBLE WIDTH, DOUBLE INLET (DWDI)



ARRANGEMENT 3
Belt Driven or Direct Drive



ARRANGEMENT 3F
Belt Driven



ARRANGEMENT 3DI
Belt Driven or Direct Drive



ARRANGEMENT 7
Direct Drive



ARRANGEMENT 7DI
Direct Drive

EXPLODED VIEW - CENTRIFUGAL FANS

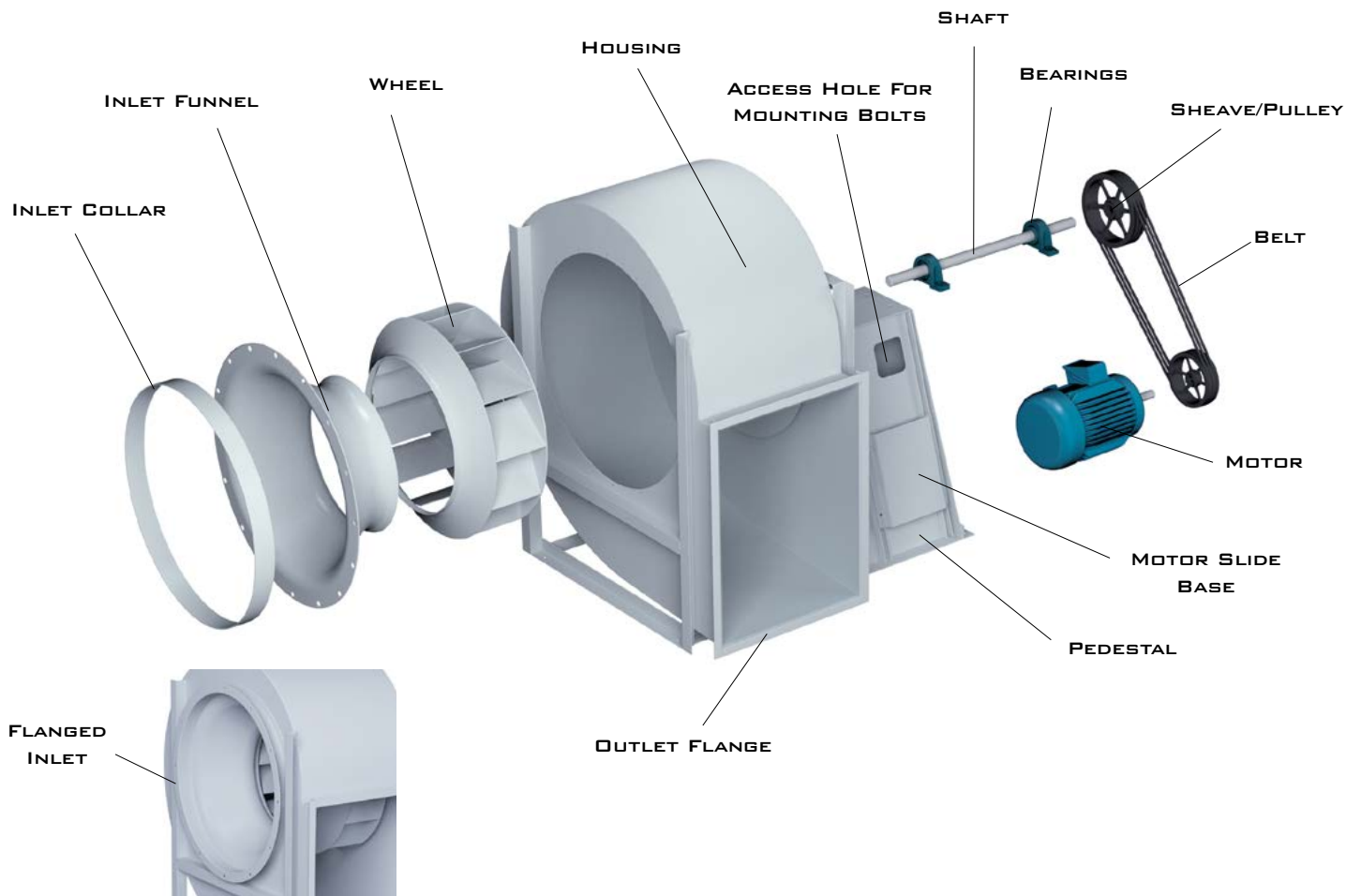

WHEEL NOMENCLATURE

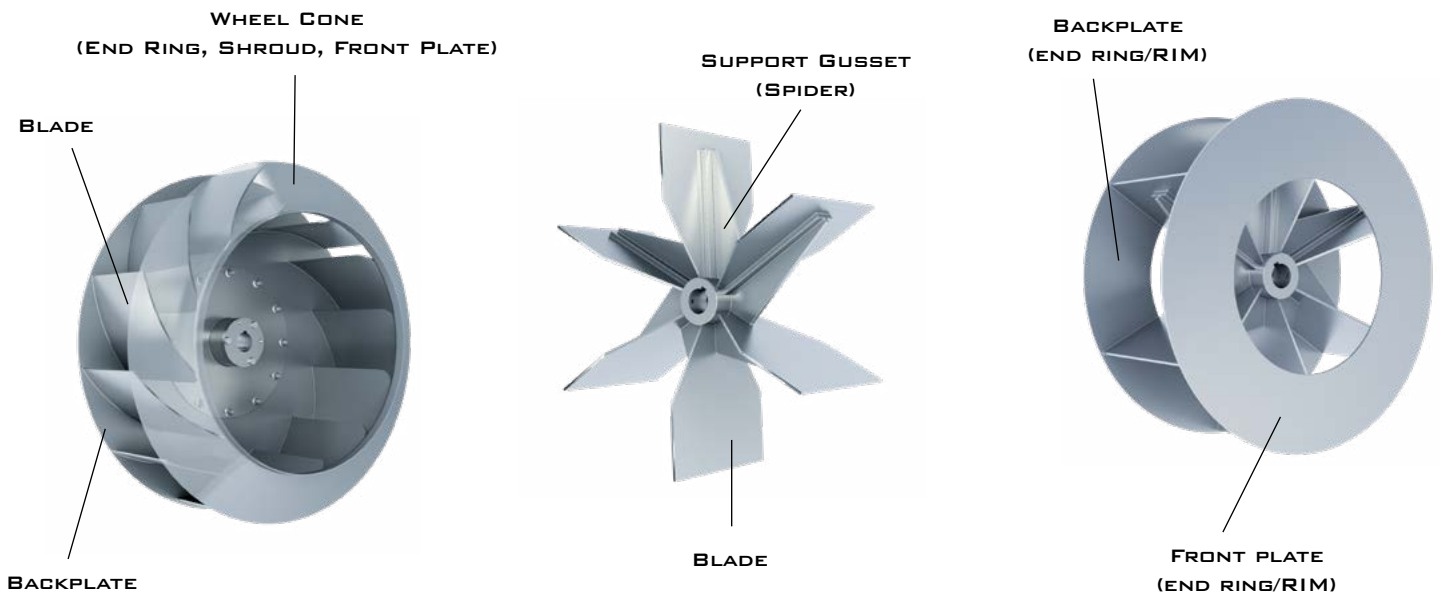

SWSI WHEEL TYPES



AIRFOIL
CAE-SW
SWCBF
BAUB

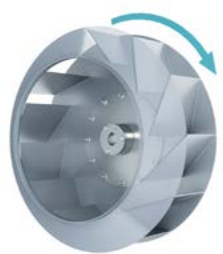

BACKWARD INCLINED
CB-SW
BIUB
BIUBR
BIUBSH

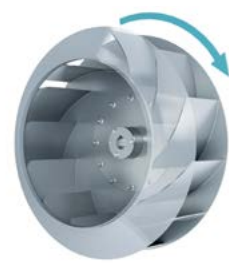

BACKWARD CURVED
BCF



RADIAL BLADED
RBF MHR PB
MHA MHW CABD
MHO HPBA CA
MHP HPBS HPBF



FORWARD CURVED
FCUB
DFC

DWDI WHEEL TYPES

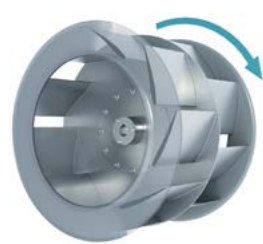

AIRFOIL
CAE-DW

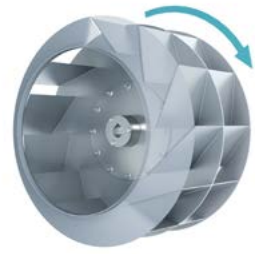

BACKWARD INCLINED
CB-DW

WHEEL ROTATION

ROTATION VIEW FROM DRIVE SIDE

**CLOCKWISE (CW)
EXAMPLE SHOWN**

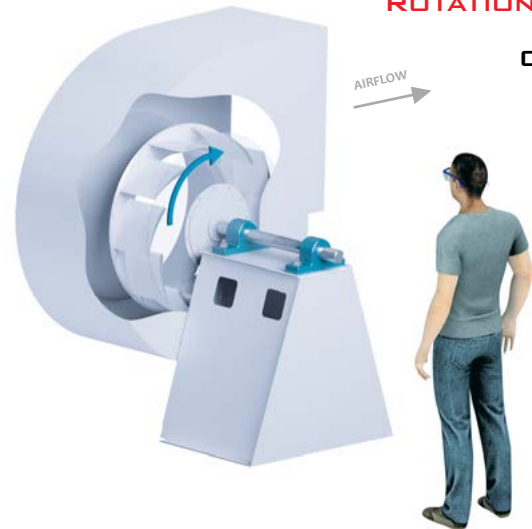

SWSI CENTRIFUGAL FANS

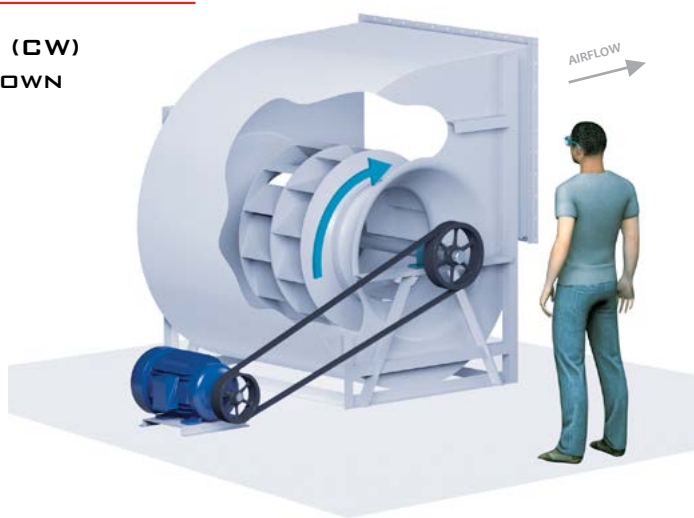

DWDI CENTRIFUGAL FANS

SAFETY & HAZARD WARNINGS

For general safety practices for air moving equipment, see AMCA Bulletin 410. Aerovent offers many safety accessories. These safety devices include (but are not limited to) belt guards, shaft guards, inlet and discharge screens. The use and suitability of safety devices is the responsibility of the purchaser.

Facility related safety conditions include fans' accessibility and location. How easily can non-service personnel access the unit? Is the fan in a hazardous duty environment? Was the unit ordered for this duty? Other concerns must also be addressed. All fans should be powered through controls that are easily accessible to service personnel from the fan. Fan power must have the ability to be "locked out" by service personnel trained in lockout/tagout procedures per OSHA requirements (29CFR1910.147). When performing lockout, be aware of factors, such as building pressure and additional fans in the system that can influence unwanted fan rotation (wind milling). If you have any doubt about your ability to perform a task, seek a person qualified to do that task. Before any work is done on a fan, ensure that the fan is isolated from the electrical supply using a 'lockout/tagout system.'

Note: A stationary, non-rotating fan does not mean that the fan is isolated from the electrical supply or from other fans/dampers in the system that could cause the fan wheel to rotate. A non-rotating fan could be subject to controls or other circuit protection devices that may start the fan without notice.

The following safety precautions should be followed, where applicable:

- Do not attempt to slow a rotating wheel even when it is isolated from the electrical supply. Fan impellers have a high inertia and injury could result from an attempt to stop it. It is recommended that the impeller is isolated by closing off the inlet or outlet to prevent wind-driven rotation. If a wheel is chocked to prevent rotation, ensure that the chocks are removed prior to start up.
- Wear appropriate personal protective equipment. This may include protective clothing, eye protection, ear protection, respiratory equipment, hand and foot protection when installing or servicing the fan.
- Always use caution when entering a fan's air path. High velocity airflow can cause you to lose your balance.
- Motor, bearings and drives can be hot, and similarly if the fan is subject to processes that are hot, the fan housing could be hot.
- Fans are often used to move hazardous materials that could be dangerous. Always wear protective clothing and take precautions not to inhale dust/gases. If hazardous chemical vapors are present, respiratory equipment may be required.
- Sharp edges – wear protective gloves when handling, installing or servicing a fan.
- Fans can operate at high decibel sound levels. Wear proper ear protection to protect from excessive noise levels.
- Access doors – Do not open access doors when fan is in operation. The effects of suction and air pressure could result in injury.
- When working around pulleys and belts, keep hands away from pinch points. This pertains to when the fan is under or off power.

Throughout this manual, there are a number of HAZARD WARNINGS that must be read and adhered to in order to prevent possible personal injury and/or damage to equipment. Two signal words "WARNING" and "CAUTION" are used to indicate the severity of a hazard and are preceded by the safety alert symbol. It is the responsibility of all personnel involved in installation, operation and maintenance to fully understand the warning and caution procedures by which hazards are to be avoided.

 **WARNING:** Used when serious injury or death MAY result from misuse or failure to follow specific instructions.

 **CAUTION:** Used when minor or moderate injury or product / equipment damage MAY result from misuse or failure to follow specific instructions.

NOTICE: Indicates information considered important, but not hazard-related.

SHIPPING & RECEIVING

All Aerovent products are carefully constructed and inspected before shipment to insure the highest standards of quality and performance. Compare all components with the bill of lading or packing list to verify that the proper unit was received. Check each unit for any damage that may have occurred in transit. Any damage should be reported immediately to the carrier and the necessary damage report filed. Damage should be noted on the bill of lading.

HANDLING

Handling of all air moving equipment should be conducted by trained personnel and be consistent with safe handling practices. Verify the lift capacity and operating condition of handling equipment. When using hoisting equipment, only qualified and trained personnel should operate the equipment.

Units shipped completely assembled may be lifted with slings and spreader bars. (Use well-padded chains, cables or nylon straps, rated to lift the required weight.) On most units, lifting lugs are designed to protect the fan and fan housing from damage. Never lift a fan by the inlet or discharge flange, shafting or drives, wheel or impeller, motor or motor base, or in any other manner that may bend or distort parts. Never lift with slings or timbers passed through the fan inlets.

For fans provided without lifting lugs, use a forklift or pallet jack to handle the equipment. Consult a qualified person before lifting.

CAUTION

1. Maintain handling equipment to avoid serious personal injury and do not stand under the load.
2. If supplied, only use the provided lifting lugs to lift the equipment.
3. Ensure that the lifting equipment is rated for the capacity to be lifted.

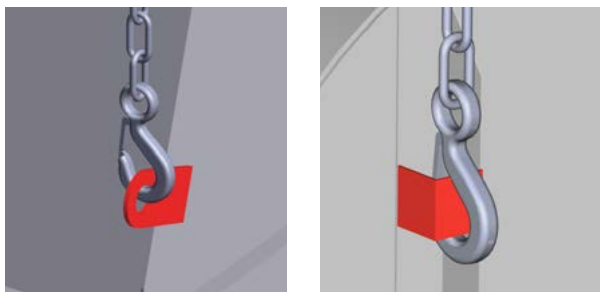

Lifting lugs are provided on most units.

Lift fans mounted to a Unitary Base as shown

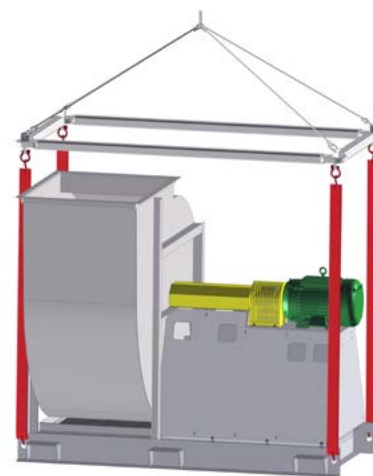

Partial or disassembled units require special handling. All parts should be handled in a method which protects the coatings and parts from damage. Components should be handled such that forces are not concentrated to avoid bending or distortion.

The housing should be lifted using suitably rated spreader bars and padded Chains or straps. Do not distort housing or side plates when lifting.

The shaft and wheel assembly may be lifted using a hoist and a spreader with slings around the shaft at either side of the wheel. Use the spreader bar to ensure that the slings do not push against the sides of the wheel as this may distort the wheel. Take care not to damage the shaft where the wheel or bearings will be mounted. Never lift or support the assembly by the wheel. Always support the assembly by the shaft when lifting or storing (see the section regarding proper storage of equipment.) Do not support the shaft or the wheel on the housing sides. See the Fan Installation section for additional details.

Wheels shipped separately can be lifted by slings running between the blades or through the hub. Never lift the wheel by a single blade or single point on the flange/shroud. Do not to put a chain within the hub bore. Always transport wheels by lifting, do not roll the wheel as this can damage coatings and change the balance of the wheel.

Bent shafting is a source of vibration and bearing failure, so be sure to handle the shaft with care. If the shaft is bent, replace the shaft. Any scratches on the shaft may be repaired with fine emery cloth or a stone. Remove only the displaced metal that forms a high point at the edge of the scratch.

CAUTION

1. Bearing pedestals should be lifted using straps or padded chains. Under no circumstance should an attached or separated bearing pedestal be lifted by the shaft, bearings, drives, motor or wheel.
2. Note some rotor assemblies may have an off-center CoG and therefore a qualified person should be consulted before lifting.

UNIT STORAGE

Store the unit in an environmentally stable and protected area. During storage, the fan should not be subjected to vibration from external sources or bearing damage may occur. The unit should be reasonably protected from any accidental impacts. Cover the fan to protect coatings and to prevent any foreign material or moisture from entering the bearings, motor, inlet or discharge. Take care to protect the motor, drives and bearings.

Extended storage requires monthly inspections. Check for corrosion or damage to the unit and for debris within the fan.

Bearings tend to take on moisture if the atmosphere in which they are stored is not at a constant temperature. To avoid corrosion, it is necessary to keep the bearings full of grease and to rotate them periodically. Even when full of grease, bearings will take on moisture, so it is necessary to purge the bearings with new grease to expel moisture every thirty days. It is recommended that the bearings be purged with grease while being rotated by hand. Do not use high pressure greasers as they may ruin the bearing seals. Spherical roller bearings with split pillowblock housings must be opened up and grease removed before start-up. Remove old/excess grease and regrease the bearing in accordance with the bearing manufacturer's instructions.

The drives and belts should be removed if the fan is to be stored for a prolonged period. The drives should be labeled for service and stored in a dry place. Belts should be removed, coiled without kinks, placed in a heavy carton and stored in a dry, well-ventilated place. To prevent belt deterioration storage conditions should not exceed 85°F and 70% humidity. If belts show signs of deterioration, they should be replaced prior to start-up.

Motors should be stored in a clean, dry, vibration-free location. The packaging should be opened up enough to allow air circulation around the motor. The winding temperature should be kept slightly above that of the surroundings to prevent condensation. This can be accomplished by energizing the internal heaters, if the motor is so equipped, or by using space heaters. If it is impossible to heat the windings, the motor should be wrapped tightly with a waterproof material which also encloses several bags of desiccant. Replace the desiccant regularly to prevent moisture problems. The motor rotor should also be rotated regularly (monthly) to assure the bearing parts are well greased. Shafts on motors equipped with shaft grounding rings must remain rust free. Failure to do so renders the grounding feature inoperative and may result in bearing failure under VFD operation. Consult the motor manufacturer for further detail on motor storage and start up after longer periods of storage. It may be necessary to regrease the bearings. If the fan's bearings or motor bearings have extended lubrication lines, it will be necessary to replace the grease by detaching from the motor/bearing and purging the line with new grease.



WARNING

Refer to handling section prior to lifting equipment.

FOUNDATIONS & SUPPORTING STRUCTURES (REFER TO LIFTING/SAFETY SECTION)

The best means of floor mounting a fan is on a well-designed, flat, level and prepared concrete foundation. The foundation should have a mass of at least three times that of the supported assembly. Rigid foundation stiffness must be between 1×10^6 lbs./in. to 4×10^6 lbs./in. depending upon size and speed. The foundation should extend 6" beyond the outer dimensions of the fan and driver; however, it should be no more than twice the area required for the equipment. If it is made larger, the mass should be increased accordingly to resist rocking modes of vibration. Anchor bolts should be carefully located by a competent tradesman as wheel to inlet, bearing location and motor location are critical to final fan alignment. J or T type anchor bolts of sufficient size should be used and should be tied into the reinforcing bar for the foundation. Pipe sleeves may be incorporated when pouring the concrete. After the concrete is poured, a pipe sleeve with a diameter of 2 to 2½ times the anchor bolt diameter should be provided around the anchor bolt for final adjustment. The mounting surface of the foundation should be smooth for good shim contact. It may be necessary to grind high spots. When deciding the thickness of the foundation, approximately 1 to 1½" height should be allowed for shimming, grouting, leveling, washers, nuts, etc. The above represents industry best practice. Actual foundation design should be entrusted to a qualified engineer. Anchor bolts should be accurately placed to coincide with the predetermined fan securing holes, or the manufactured base, to ensure that the fan is not distorted (this may impact alignment and vibration.)

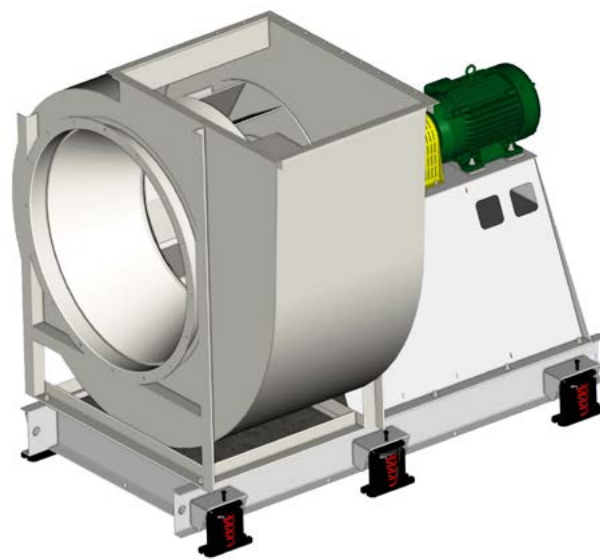
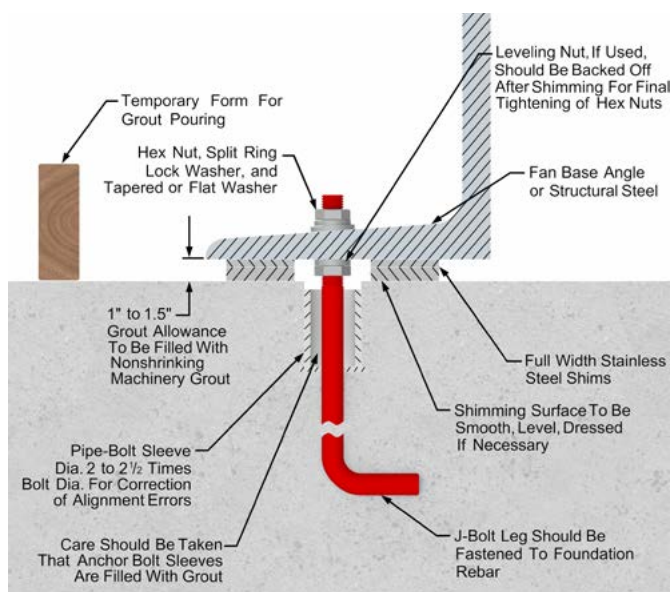

Fan mounted on an inertia base.
Base and pedestal shown filled with reinforced concrete.

Fans mounted on a sub-floor or mezzanine must have adequate stiffness or be mounted on an inertia base with springs properly selected. An inertia base is recommended for arrangement 8 fans to ensure alignment of the rotor and drive.

If a structural steel base or platform is to be used, the structure must be designed for the weight of the fan, live loads imposed by rotation of the rotor and driver, and any external live loads. The structure should be designed to ensure that no natural frequency will occur within 30% of the fan speed. This is especially true if the structure supports more than one fan. Inertia bases are generally recommended to provide adequate mass and stiffness for fan operation.

Any ducting should have independent support. Do not use the fan to support ducting as the housing or pedestal may become distorted. The fan frame can be designed to carry some external loads. Consult the factory if this is a concern. Isolating the fan from ductwork with flex connections eliminates transmission of vibration. Fans handling hot gases require expansion joints at both the inlet and discharge to prevent excessive loads caused by thermal growth.

FAN INSTALLATION – FACTORY ASSEMBLED UNITS (REFER TO LIFTING/SAFETY SECTION)

All fan wheels are statically and dynamically balanced using state of the art equipment in the factory. Final trim balancing is performed on factory assembled fans, unless the specified electrical characteristics of the motor are outside the limits of the factory test equipment. If the motor and drives are supplied, the complete assembly is run tested and balanced. Infrequently, fans are supplied with unusual electrical characteristics and cannot be tested with the motor. In this situation the fans are run and balanced using a factory driver. Likewise, if motors and/or drives are not supplied, the fan is tested with the factory driver. Final balancing, at the buyer's expense, should be performed in the field after the motor and/or drives are installed. This service is available from Aerovent, otherwise this should be entrusted to a qualified technician.

Follow proper handling instructions as given earlier.

1. Move the fan to the final mounting position.
2. Remove skid, crates and packing materials carefully.
3. If vibration isolation is to be used, place isolation base on mounting bolts. Line up holes in fan base with bolts. See Item 10 in the "Optional Accessories" section for preparing inertia bases for use.
4. Place the fan on mounting structure. Carefully level the unit (checking the level on the shaft) on the foundation and shim as necessary using stainless steel shims on both sides of each anchor bolt. Back off leveling nuts if used. Be careful not to force the fan to the mounting structure/foundation. This may cause the bearings to become misaligned or pinched causing vibration and premature failure.
5. Check the alignment of the bearings. Shim or reposition the bearings if necessary.
6. Check alignment of sheaves on belt driven fans.
7. Check tension of belts to see if it is sufficient. Sheaves on belt driven fans are often provided with taperlock bushings. When tightening bushing bolts, proceed in a progressive manner to avoid cocking the tapered surfaces between the bushing and the sheave. Torque per tables on the right.

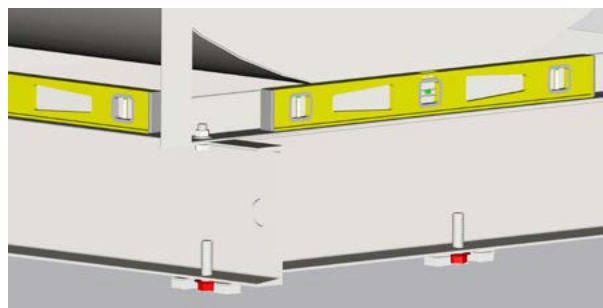

Carefully level the fan on the foundation

 **CLICK TO VIEW OUR SHEAVE INSTALLATION VIDEO**

8. Check alignment of factory mounted couplings, as they are subject to misalignment during shipment and installation. Realign to within 0.002" offset and parallel. Allow for thermal growth of the motor by setting the motor 0.001" low for each inch of shaft up to 0.005".

NOTICE
Most couplings need lubrication.

9. Check the tightness of the wheel on the shaft. Check the tightness of foundation bolts, motor bolts, sheaves and bearings. Make sure there is no rubbing or binding and that the wheel-inlet cone clearances and overlap are correct.
10. Check that bearings are fully lubricated and check the oil level in the static oil lube systems. For spherical roller bearings with split pillowblock housings, the bottom half of the housings should be 1/3 full of grease. For oil lube bearings, the oil level should reach the midpoint of the bottom roller or ball.
11. Install any accessories shipped loose from the factory.

TIGHTENING TORQUE

SIZE	FASTENER - TIGHTENING TORQUE (Ft. Lbs.)		
	GRADE 2	GRADE 5	GRADE 8
#10	—	—	—
1/4-20	5.5	8	12
3/16-18	11	17	25
3/8-16	22	30	45
7/16-14	30	50	70
1/2-13	55	75	110
9/16-12	—	—	—
5/8-11	100	150	200
3/4-10	150	270	380
7/8-9	165	430	600
1-8	250	645	900
1 1/4-7	500	1120	1500

SIZE	TAPER BUSHINGS - TIGHTENING TORQUE (Ft. Lbs.)		
	SPLIT		QD FOR DRIVE
	IN IRON	IN ALUM. HUB	
#10	—	—	6
1/4-20	7.9	7.5	9
3/16-18	16	13	15
3/8-16	29	24	30
7/16-14	—	—	—
1/2-13	70	—	60
9/16-12	—	—	75
5/8-11	140	112	135
3/4-10	—	—	—
7/8-9	—	—	—
1-8	—	—	—
1 1/4-7	—	—	—

The above torque values are for nonlubricated fasteners and Browning Bushings. For bearing setscrews, use manufacturer's recommendations. If other bushings are used, utilize bushing manufacturer's specifications.

Tolerance: +/- 5%
For wheel setscrews use Grade 2 values.

FAN INSTALLATION – DISASSEMBLED UNITS WITH SPLIT HOUSINGS

(REFER TO LIFTING/SAFETY SECTION)

A unit is considered “disassembled” if any component required for proper operation is shipped or supplied separately or in pieces. Reference earlier instructions concerning proper handling of fan components and general safety. Wheel rotation is important. Rotation is viewed from the drive side unless otherwise noted on the drawing.

All units where assembly of the fan housing or bearing pedestal or drive stand is required will have tags or matchmarks on adjacent parts. These are used to identify which components are joined together. Units which require extensive assembly may require additional instructions located in other sections of this manual. Special instructions for some components and accessories are sent with the shipment.

1. Move the lower half of the housing to its mounting location.
2. Remove skids, crates, and packing materials carefully.
3. If vibration isolation is to be used, place the vibration isolation base on mounting bolts. Line up holes in fan base with bolts. See Item 10 in the "Optional Accessories" section for preparing inertia bases for use.
4. Place the lower housing on the mounting structure. Carefully level the lower housing on the foundation and shim as necessary using stainless steel shims on both sides of each anchor bolt. **IMPORTANT: Back off leveling nuts if used.**
5. If the bearing pedestal(s) are separated they should be installed next.
 - a. Move bearing pedestal(s) to mounting location.
 - b. Set pedestal(s) on bolt(s).
 - c. Do not distort bearing pedestal by forcing it to align with a non-level foundation. (The concrete foundation should be properly dressed.) Place shims on either side of the foundation studs and back off leveling nuts.
 - d. Check the bearing centerline height. Adjust the height to match centerline height of the housing. High temperature units may require a lower housing centerline/inlet when cold so that it will be centered when hot.
 - e. Bring the bearing pedestal into square with the housing using careful measurements or a large square.
 - f. Shim and bolt the pedestal into position.

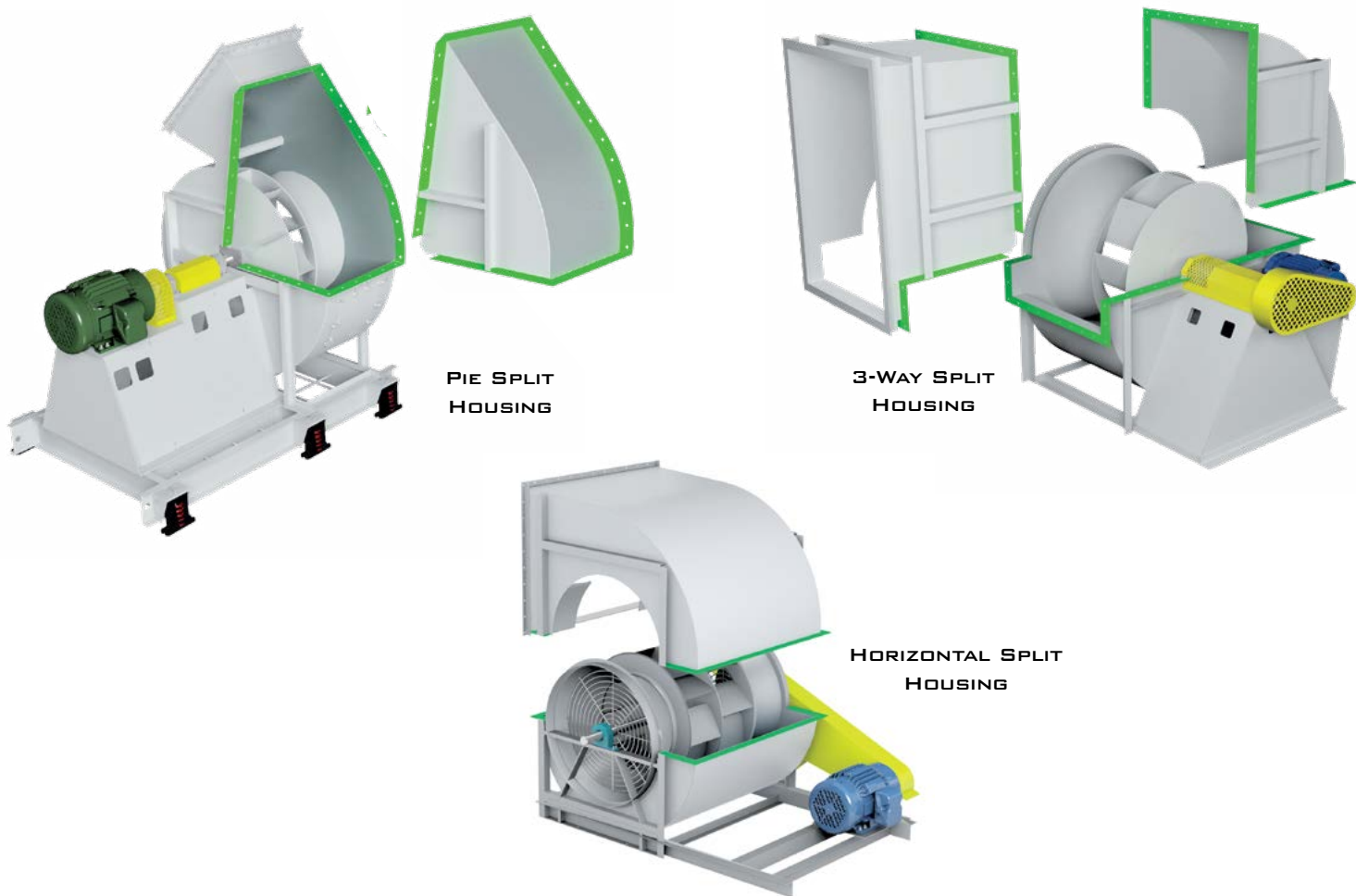

FAN INSTALLATION – DISASSEMBLED UNITS WITH SPLIT HOUSINGS (CONT.)

(REFER TO LIFTING/SAFETY SECTION)

6. If the wheel and shaft were shipped unassembled, you must now install the shaft in the wheel.
 - a. First use solvent to clean the protective coating off the shaft. Check all surfaces for corrosion or nicks and clean if necessary with fine emery cloth or a stone. After thoroughly cleaning the shaft with solvent, do not touch it with bare hands as perspiration can cause rust or pitting over time.
 - b. Remove keys from the shaft.
 - c. Clean the inside of the wheel bore with solvent. Make sure the setscrews will not interfere when inserting the shaft into the wheel bore.
 - d. Insert the shaft into the wheel from the back side of the wheel.
 - e. When the shaft is flush with the wheel hub (Arr. 1, 9 and 8), dress the key if necessary, insert into the keyway and tighten the wheel setscrews.
 - f. For Arrangement 3 fans, refer to the drawing for appropriate wheel and shaft dimensional relationship.
 - g. Check the assembly drawing to make sure that the wheel and shaft have been assembled correctly.



CLICK TO VIEW OUR
WHEEL INSTALLATION/REMOVAL VIDEO



CLICK TO VIEW OUR
ROTOR INSTALLATION/REMOVAL VIDEO

7. The rotor can now be installed in the housing. Slide the bearings on if they are solid pillowblocks or loosely mount the bottom halves if they are split. Inlet vanes and/or inlet funnels may need to be installed over the shaft before installing and bolting the bearings to their supports (Arr. 3 and 7). Insert the inlets into the wheel inlet and tie them off for lifting and placing in the housing. Refer to steps 8 and 9 for order of assembly of components for double width and single width fans. The shaft should be cleaned and oiled where it will contact the bearings. Carefully lower the shaft assembly into the bearings. Use care when lowering the shaft onto the bearings so thrust bearings, collars, and liners are not damaged due to misalignment. The bearing housing should be parallel to the axis of the shaft to prevent loads caused by misalignment. Precision shim bearings as required. Lock bearings. Be sure expansion bearing (if supplied) is set to allow for thermal growth. Refer to bearing installation instructions in this installation manual.

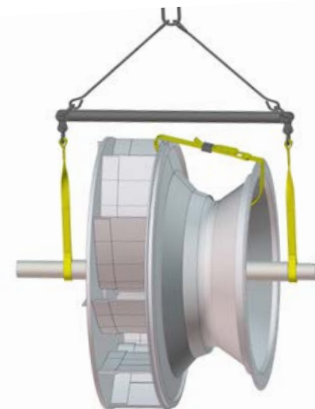

8. Arrangement 3 (split-housed) units:
 - a. Parts on a DWDI unit are assembled in the following order as viewed from opposite drive side: bearing bar assembly (or independent pedestal) and opposite bearing, funnel (housing side), wheel (housing side), funnel, drive side bearing bar assembly (pedestal), drive bearing and sheaves or coupling. Mount bearing bar assembly to housing. Center wheel in funnels.
 - b. Assemble parts in above order on shaft.
 - c. Proceed with connection of the shaft assembly to supports in step 7 above.
9. Parts on a SWSI unit are assembled in the following order as viewed from opposite drive side: bearing bar assembly and opposite bearing, funnel (housing side), wheel (housing side), drive side bearing bar assembly, drive bearing and sheaves. Mount bearing bar assembly to housing. **Refer to the wheel-funnel overlap section.**
 - a. Assemble parts in above order on shaft.
 - b. Proceed with connection of the shaft assembly to supports in step 7.
10. Install motor on the base if applicable. Carefully align shafts for drive installation. After the fan is leveled, prior to grouting, back off leveling nuts if used.

BEARING INSTALLATION (REFER TO SAFETY SECTION)

The following section gives some general instructions on bearing installation. If bearings are to be field installed, the specific installation manual for the bearings will be provided and should be followed carefully. If provided, check the assembly drawings and bearing manufacturer's instructions for location of the fixed and expansion bearings. The positions of these bearings cannot be interchanged. Always follow the bearing manufacturer's instructions.

Solid Pillowblock

1. Lightly lubricate the bearing bore and slide bearing into the proper position on the shaft. Sling the rotor assembly into place and loosely bolt the bearings in place.
2. When bearings are in place, shim appropriately and torque the base bolts using values from the Tightening Torque table on page 9. Tighten the collar setscrews to manufacturer's specification. The setscrews on both bearings should be aligned with one another. If the bearing has an adapter mount, hand tighten the locknut to establish the "zero" point. Next, tighten the number of turns per the instructions furnished with the bearing. Rotate by hand to be sure the bearings and shaft rotate freely.
3. Ensure the expansion bearing is centered within its housing. If bearings need to be forced onto the shaft then apply force on the inner race/collar only (does not apply to adapter mount.) If an expansion bearing has been supplied, it should not be bolted to the pedestal until the fixed bearing has been bolted and locked. After locking the expansion bearing to the shaft, position the pillowblock to allow for axial expansion, approximately centered in the pillowblock, then bolt to the pedestal.
4. Unless the user orders differently, bearings are lubricated in the factory with a lithium complex, NLGI grade 2 grease. **Refer to the bearing lubrication schedule on the next page.**



Solid Pillowblock Bearings

Spherical Roller Bearings with Split Pillowblock Housings

1. The bearings should be disassembled, taking care not to interchange parts between bearings. Tops of housings are not interchangeable with the bottom half pillowblock from another bearing. Pins locate the top half of the housing to prevent it from being installed in the reverse.
2. The lower bearing housing should be bolted loosely to the pedestal and seals; bearing and adapter sleeve should be placed loosely on the shaft.
3. The rotor assembly with the seals and bearings should next be positioned over the housings and carefully placed into the lower housings.
4. The stabilizing ring, sometimes referred to as the "C" ring, is installed in the bearing closest to the drive sheave or coupling unless otherwise noted in the drawing. The bearing race should be centered in the expansion bearing. The exception may be on Arrangement 3 or 7 fans with a high operating temperature. Refer to the fan drawing for location. The "C" ring is not used in the expansion bearing.
5. When installing adapter sleeves, tighten for reduction in clearance per manufacturer's instructions.
6. Bend down a tab on the lockwasher after finishing adjustment. Some brands of bearings do not utilize a lockwasher. Instead you will find allen-head setscrews in the locknut outside diameter. Tighten the setscrew after reduction in clearance is attained.
7. Grease or oil according to manufacturer's instructions. Grease/Lube will likely include the partial fill of the housing internal cavities.
8. Install the bearing housing cap bolts and bearing mounting bolts. Tighten bearing housing cap bolts and bearing mounting bolts. Torque to bearing manufacturer's instructions.



Split Pillowblock Bearings

Sleeve Bearings

1. The bearings should be disassembled and cleaned with appropriate solvent, taking care not to interchange parts between bearings. Parts of one bearing are generally not interchangeable with parts from another bearing. Bearing caps are matched to the bottom half of the pillowblock and are not interchangeable with other pillowblocks.
2. The lower bearing housings should be bolted loosely to the pedestal. The lower liner should then be placed in the housing.
3. Oil the lower liners per manufacturer's instructions and carefully sling the rotor assembly into place, being very careful not to damage the bearing liners.
4. Install thrust collars and thrust plates in the fixed bearing
5. Make sure to install the oil slinger rings in their correct location and peen the ring screws in place.
6. When handling the liners, be careful not to damage the surfaces, as they are babbitted and are fragile.
7. The housings are generally tapped with a number of ports. Be sure the oil level gauge, circulating oil supply and discharge, thermocouples, etc., are correctly placed for accessibility.
8. Make sure that proper oil type and quantity is used. Refer to the fan general assembly drawing.
9. Make sure that the thrust collar screws, liner screws, cap bolts, and plunger are torqued to manufacturer's specifications. Bearing instructions are shipped with the fan. Instructions can also be found on the bearing manufacturer's website.

SAFETY & BEARING LUBRICATION INSTRUCTIONS



WARNING

1. This equipment must not be operated without proper guarding of all moving parts. While performing maintenance be sure remote power switches are locked off. See installation manual for recommended safety practices.
2. Before starting: Check all setscrews for tightness and rotate wheel by hand to make sure it has not moved in transit.

Fans with Unit Roller Bearings

Shaft DIA	Relubrication Schedule (Months)*								Grease to be added at each interval
	Spherical Roller Bearing - Solid Pillowblocks								
	Speed (RPM)								
	500	1000	1500	2000	2500	3000	3500	4000	4500
1" thru 1 1/4" (25 - 35)	6	4	4	2	1	1	1	1	1/2
1 1/4" thru 2 3/16" (40 - 55)	4	2	1 1/2	1	1/2	1/2	1/2	1/2	1/2
2 3/16" thru 3 3/16" (60 - 85)	3	1 1/2	1	1/2	1/2	1/4	1/4		
3 3/16" thru 4 3/16" (90 - 125)	2 1/2	1	1/2	1/4					

* Suggested lubrication interval under ideal continuous operating conditions. Relubricate while running, if safety permits, until some purging occurs at seals. Adjust lubrication frequency depending on conditions of purged grease. Use one-half of listed interval for vertical shaft applications or for 24 hour operation. Hours of operation, temperature and surrounding conditions will affect the relubrication frequency required.

1. Lubricate with a high quality NLGI No. 2 lithium-base grease having rust inhibitors and antioxidant additives, and a minimum oil viscosity of 500 SUS at 100°F (38°C). Some greases having these properties are:
 Shell - Gadus S2 V100 2 Mobil - Ronex MP
 Mobil - Mobilith SHC100 Mobil - Mobilith SHC220
2. Lubricate bearings prior to extended shutdown or storage and rotate shaft monthly to aid corrosion protection.
3. Any lubrication requirements noted on the general assembly drawing supersede requirements found here.

Fans with Ball Bearings

Shaft DIA	Relubrication Schedule (Months)*								Grease to be added at each interval
	Ball Bearing Pillowblocks								
	Speed (RPM)								
	500	1000	1500	2000	2500	3000	3500	4000	4500
1/2" thru 1 1/8" (13 - 45)	6	6	5	3	3	2	2	2	1
1 1/8" thru 2 1/8" (50 - 60)	6	5	4	2	2	1	1	1	1
2 1/8" thru 2 3/8" (65 - 75)	5	4	3	2	1	1	1		
3 3/8" thru 3 7/8" (80 - 100)	4	3	2	1	1				

* Suggested lubrication interval under ideal continuous operating conditions. Relubricate while running, if safety permits, until some purging occurs at seals. Adjust lubrication frequency depending on conditions of purged grease. Use one-half of listed interval for vertical shaft applications or for 24 hour operation. Hours of operation, temperature and surrounding conditions will affect the relubrication frequency required.

1. Lubricate with a high quality NLGI No. 2 lithium-base grease having rust inhibitors and antioxidant additives, and a minimum oil viscosity of 500 SUS at 100°F (38°C). Some greases having these properties are:
 Shell - Gadus S2 V100 2 Mobil - Ronex MP
 Mobil - Mobilith SHC100 Mobil - Mobilith SHC220
2. Lubricate bearings prior to extended shutdown or storage and rotate shaft monthly to aid corrosion protection.
3. Any lubrication requirements noted on the general assembly drawing supersede requirements found here.

Fans with Spherical Roller Bearings with Split Pillowblock Housings

Shaft DIA	Relubrication Schedule (Months)*								Grease to be added at each interval	
	Spherical Roller Bearing - Split Pillowblocks									
	Speed (RPM)									
	500	750	1000	1500	2000	2500	3000	3500	4000	
1 1/8" thru 1 5/8" (35 - 50)	6	4 1/2	4	4	3 1/2	2 1/2	2 1/2	1	1	0.50 oz.
2 3/8" thru 2 3/8" (55 - 70)	5	4 1/2	4	2 1/2	2 1/2	1 1/2	1 1/2	1/4	1/4	0.75 oz.
2 3/8" thru 3 3/8" (75 - 100)	4 1/2	4	3 1/2	2 1/2	1 1/2	1	1/2			2.00 oz.
4 1/2" thru 4 3/8" (110 - 135)	4	4	2 1/2	1	1/2					4.00 oz.
5 1/8" thru 6 3/8" (140 - 180)	4	2 1/2	1 1/2							8.5 oz.

* Suggested lubrication interval under ideal continuous operating conditions. Remove bearing cap and observe condition of used grease after lubricating. Adjust lubrication frequency as needed. Use one-half of listed interval for vertical shaft applications or for 24 hour operation. Hours of operation, temperature, and surrounding conditions will affect the relubrication frequency required. Clean and repack bearings annually. Remove old grease, pack bearing full and fill housing reservoir on both sides of bearings to bottom of shaft.

1. Lubricate with a high quality NLGI No. 2 lithium-base grease having rust inhibitors and antioxidant additives, and a minimum oil viscosity of 500 SUS at 100°F (38°C). Some greases having these properties are:
 Shell - Gadus S2 V100 2 Mobil - Ronex MP
 Mobil - Mobilith SHC100 Mobil - Mobilith SHC220
2. Lubricate bearings prior to extended shutdown or storage and rotate shaft monthly to aid corrosion protection.
3. Purge or remove old grease when changing lubrication brands or types.
4. Any lubrication requirements noted on the general assembly drawing supersede requirements found here.

Static Oil Lubrication

1. Use only high quality mineral oil with a VG grade indicated on the customer submittal drawing.
2. Static oil level should be at the center of the lower-most roller. (Do not overfill.)
3. Complete lubrication change should be made annually.



DRIVE MOUNTING

(REFER TO SAFETY SECTION)

Mount drives as follows:

1. Slip (do not pound) proper sheave onto corresponding shaft. Most drives utilize tapered bushings. Draw the bushing up evenly tightening in steps. To minimize bearing loading, mount sheaves as close to bearings as possible. It is preferable to use alignment tools that align the grooves of the sheave.
2. Laser alignment is common. The mechanic must be familiar with the alignment tool he is using. Otherwise, align sheaves with straightedge extended along sheaves, just making contact in two places on outside perimeters of both sheaves. This “four-point” alignment may also be checked with a string tied to the shaft behind one of the sheaves. The string is then pulled taut over the faces of the sheaves to check the alignment at the four points at the outside perimeters. Each sheave should be rotated about one-half revolution during this check to look for excessive runout or a bent shaft. Unless there is a bent shaft, runout can be corrected by adjustments to the bolt torque of the taper bushing.
3. Install and tighten the belts. Run the drive for a few minutes to seat the belts. When fitting the belts, slide the motor in to fit the belts on. Do not use a pry bar, as this may damage the belt cords. Tighten the belts to the proper tension. Ideal tension is just enough tension so that the belts do not slip under peak load or acceleration. Many drives are provided with tensioning data which identifies the load to apply at the center of the span and the allowable deflection from this force. A belt tension gauge is recommended for precise tensioning.
4. After initial installation of belts, recheck belt tension again after a few days of operation to adjust belt tension. (New belts require a break-in period of operation.)

WARNING

When working around belts and pulleys, keep hands away from pinch points.

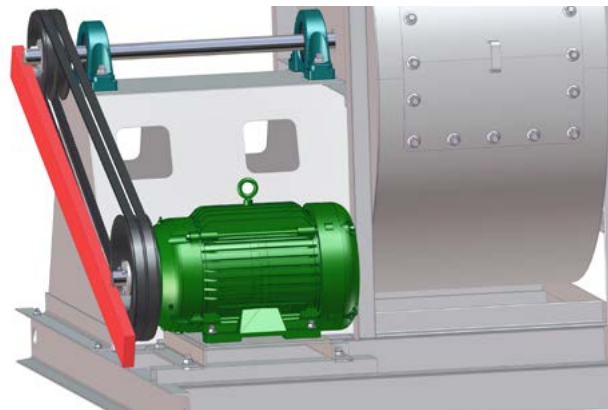

 [CLICK TO VIEW OUR SHEAVE INSTALLATION VIDEO](#)

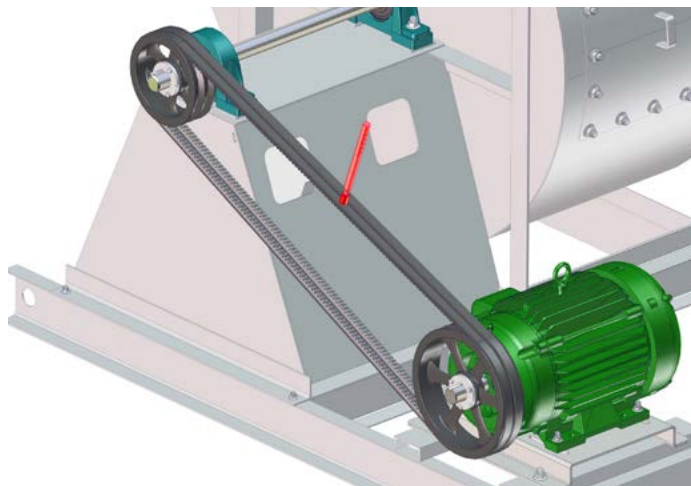

CAUTION

Placing fan sheave on motor can overspeed wheel and cause structural failure.

FLEXIBLE COUPLINGS (REFER TO SAFETY SECTION)

These instructions are general for the installation of several types of flexible couplings and should not be used as a substitute for more specific manufacturer's instructions. The coupling manufacturer's installation data is available and will give specific dimensions for alignment limits, lubricants, etc. Refer to Item 7 in "Factory Assembled Units" section for coupling alignment requirements.

Before preparing to mount the coupling, make sure that all bearings, inlet vanes, shaft seals or other components have been installed on the shaft.

When mounting and keying the coupling halves to the shaft, follow supplied instructions for heating and shrink fitting. Set the coupling halves for the normal gap specified by the manufacturer. Coupling gap is illustrated below. It is advisable to set the motor on the pedestal first to better determine the placement of the coupling on the shaft.

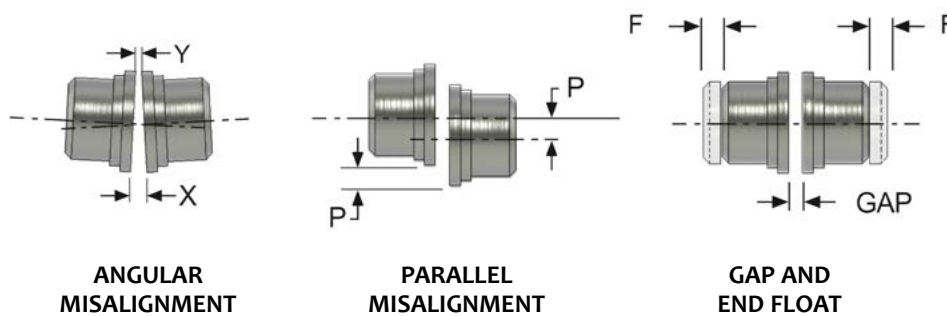

- X-Y = ANGULAR MISALIGNMENT
 P = PARALLEL OFFSET (MISALIGNMENT)
 F = END FLOAT*

The two types of misalignment are illustrated above. Alternatively angular alignment is checked with feeler gauges between the hub faces. When angular alignment has been adjusted to manufacturer's specification, parallel alignment can be checked with a dial indicator on the hub or a straightedge and feeler gauges on the hub halves' O.D. When shimming has brought parallel alignment within specification, angular alignment and gap should again be checked, and adjustments made if necessary. A dial indicator or laser alignment may be used to more accurately take the measurements described above.

Special adjustments may need to be made for couplings used with some equipment. As an example, when used with motors with sleeve bearings, couplings may require provisions for limiting end float. Larger drivers may grow in operation (due to heat expansion) requiring the driver side to be set slightly low when not operating. A good rule of thumb is to set the motor low by 0.001 inches per inch of motor shaft diameter up to 0.005". Refer to specific instruction manuals or assembly drawings.

Thoroughly clean the coupling halves after completion of alignment. Reassemble the coupling and tighten bolts, washers and locknuts. Lubricate per manufacturer's recommendations.

- * 1. End float is the permissible axial movement of the coupling hub(s) within the sleeves of the coupling
 2. End float will allow for thermal movement
 3. Limited end float couplings are often required in applications using motors with sleeve bearings

MAINTENANCE (REFER TO SAFETY SECTION)

Develop a regular maintenance schedule according to your needs and the criticality of the fan. Periodic inspections, lubrication, observations of sound and vibration will help prolong the life of the fan. If changes are noted check bolt tightness, foundation integrity, cleanliness of the wheel and or motor, bearing lubrication, drive components. Always keep records of the maintenance that is performed.

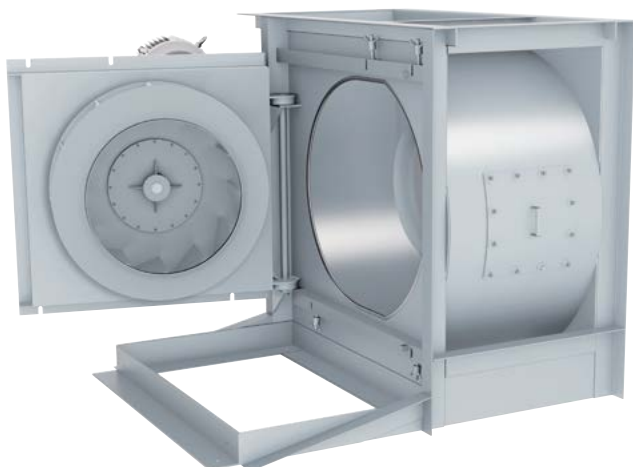

 CAUTION
<ol style="list-style-type: none"> Swingout fans should be opened for wheel cleaning and inspection only and should be closed immediately after cleaning. Isolate from the electrical supply before opening. Do not run swingout fans the fan in the open position.

MOTOR MAINTENANCE

The three basic rules of motor maintenance are:

1. Keep the motor clean.
2. Keep the motor dry.
3. Keep the motor properly lubricated.

Blow dust off periodically (with low pressure air) to prevent motor from overheating.

Some smaller motors are lubricated for life. Lubrication requirements are normally attached to the motor. Use the motor manufacturer’s recommendations for relubrication. Often motor lubricants are not the same as the fan bearings. If this information is not available, the following schedule may be used.

Shaft grounding rings are recommended for some VFD applications. If the motor is equipped with a shaft grounding ring a yearly inspection for wear and shaft corrosion is recommended. Replace the ring if it is making minimal contact with the shaft. If corrosion is present, treat the shaft with colloidal silver per the ring manufacturer's instructions.

MOTOR LUBRICATION SCHEDULE

Motors Less than 10HP Running 8 Hrs/Day (clean environments)	Motors Between 15-40HP (clean environments)	Motors Running 24/7 or if in dirty/dusty environments
Lube every 5 Years	Lube every 3 years	Divide the service interval by 4

Do not over lubricate.

DRIVE MAINTENANCE (REFER TO SAFETY SECTION)

V-belt drives need periodic inspection, retensioning and occasional belt replacement. When inspecting drives, look for dirt buildup, burrs or obstructions that can cause premature belt or drive replacement. If burrs are found, use fine emery cloth or a stone to remove them. Be careful that dust does not enter the bearings.

Check sheaves for wear. Excessive slippage of belts on sheaves can cause wear and vibration. Replace worn sheaves with new ones. Carefully align sheaves to avoid premature sheave failure. If fraying or other wear is observed to be mostly on one side of the belts, the drives may be misaligned. Realign and reinstall new belts. Tighten sheave bolts (or setscrews if appropriate).

When replacing belts, replace the entire set. Never use belt dressing on any belts, as it may cause belt wear.

 WARNING
<p>When working around belts and pulleys, keep hands away from pinch points.</p>

FAN BEARING MAINTENANCE (REFER TO SAFETY SECTION)

Proper lubrication of the fan drive bearings helps assure maximum bearing life. All fans are equipped with decals indicating the recommended relubrication intervals for normal operating conditions. **Refer to the Bearing Installation section for the lubrication schedules for ball bearings, solid pillowblock spherical roller bearings and split pillowblock spherical roller bearings.** Note that all speeds shown do not apply to all shaft sizes in that group. Consult the factory if in doubt of maximum speed for a particular bearing. Note that every installation is different and the frequency of relubrication should be adjusted accordingly.

Use 1/2 to 1/3 of the listed lubrication interval for high moisture applications. For vertical shaft mounts or dirty conditions use 1/2 the lubrication schedule.

Observation of the conditions of the grease expelled from unit ball or roller bearings at the time of relubrication is the best guide as to whether regreasing intervals and amount of grease added should be altered. Spherical roller bearings with split pillowblock housings should not be lubricated until grease purges or overheating may result. Follow the lubrication interval and amount noted in the Bearing Installation section. Spherical roller bearings with split pillowblock housings should be serviced once per year. Remove cap, clean out old grease and replace by filling the bottom half of the housing 1/3 full.

Greases are made with different bases. There are base greases, lithium base, sodium base, polyurea, etc. Avoid mixing greases with different bases. They could be incompatible and result in rapid deterioration or breakdown of the grease. The lubrication sticker identifies a list of acceptable lubricants. All bearings are filled with a lithium complex grease before leaving the factory. When the fans are started, the bearings may discharge excess grease through the labyrinth seals for a short period of time. Do not replace the initial discharge because leakage will cease when the excess grease has worked out. Sometimes the bearings have a tendency to run hotter during this period. This is no reason for alarm unless it lasts over 48 hours or temperatures exceed 200°F. When relubricating, use a sufficient amount of grease to purge the seals. Rotate bearings by hand during relubrication. If extended lubrication lines are fitted, lubricate the bearings while the fan is operating if it is safe to do so.

WHEEL AND SHAFT MAINTENANCE (REFER TO SAFETY SECTION)

Periodically inspect the shaft and wheel for dirt buildup, corrosion, and signs of excess stress or fatigue. Clean the components. If the wheel is removed for any reason, make sure that it is securely attached to the shaft before restarting the fan.

STRUCTURAL MAINTENANCE (REFER TO SAFETY SECTION)

All structural components or devices used to support or attach the fan to a structure should be checked at regular intervals. Vibration isolators, bolts, foundations, etc., are all subject to failure from corrosion, erosion and other causes. Improper mounting can lead to poor operation characteristics or fan fatigue and failure. Check metallic components for corrosion, cracks or other signs of stress. Concrete should be checked to insure the structural integrity of the foundation.

DUCT CONNECTIONS

(REFER TO SAFETY SECTION)

The fan support structure is normally not designed to carry loads imposed by the weight of ducts, silencers, stacks, etc. Supporting these loads on the fan can cause housing distortion and may cause performance or vibration problems. Use of flexible connections is recommended for all fans and imperative when using vibration isolation or handling high temperature gases.



OPTIONAL ACCESSORIES

1. **Turning Gear** — A turning gear is sometimes used in high temperature applications where the fan is exposed to high temperature gases when not in operation. The wheel and shaft can expand unevenly due to the temperature when sitting idle, which can cause vibration at startup and/or a permanent set to the rotor. The turning gear slowly turns the fan from the outboard side while it is not operating, providing for even thermal expansion. It starts automatically when the fan shuts down and disengages automatically when the fan starts up again. More specific information will be provided for each application.

2. **Shaft Seals** — The standard shaft seal is a wire inserted fiberglass tacky cloth element retained with an aluminum retaining plate and clips. Other configurations of shaft seals are available for special applications, such as when it is necessary to keep the shaft seal as gas tight as possible. Shaft seal application manuals are provided in Fan Engineering FE-700 available on www.aerovent.com. Other seals such as stuffing boxes, mechanical seals and carbon ring seals need special attention. It is imperative that after the fan has been leveled, shimmed, fastened to the foundation and ducted the shaft and seal be checked for concentricity and angularity. The seal must not bind when the shaft is rotated. Stuffing box packing material must not be compressed too tight by the gland or overheating will occur. Monitor temperature for a period of time. Connect a purge if specified. Carbon ring seals have pins which prevent ring rotation.

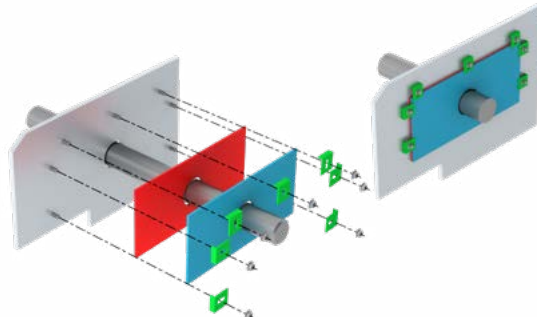

3. **Variable Inlet Vanes** — Variable inlet vanes are provided as assemblies internally in the inlet cone or externally in a flanged cylinder. The vanes are used to control volume and save power in installations where different volumetric operating conditions are used. Installation manuals are provided in other engineering supplements for specific fan types. Variable inlet vanes may be provided with powered operators in which case the manufacturer’s installation and operating manuals will be provided. Inlet vanes are unidirectional. Vanes should be stroked periodically to prevent binding and possible seizure. *Note: The weight of customer supplied vanes may need to be supported independently of the fan. Consult with Aerovent.*

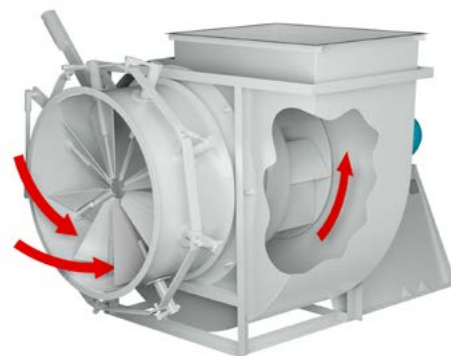

Orientation of Inlet Vanes Relative to Fan Rotation

4. **Inlet Box and Inlet Box Dampers** — Inlet boxes may be provided to allow transition from a duct to the fan inlet. Inlet box dampers may also be provided for volumetric regulation similar to inlet vanes. Dampers are usually provided as a complete assembly and are installed with the damper axles parallel to the fan shaft. They should be installed to pre-spin the air in the direction of fan rotation. Damage may occur if the fan is operated regularly with damper settings less than 30% open. Operation below 30% should be limited to start-up or occasional periods of low duration.



Orientation of Damper Blades As Related to Fan Rotation

OPTIONAL ACCESSORIES (CONT.)

5. **Outlet Dampers** — Outlet dampers are usually provided completely assembled like the inlet dampers. The damper is bolted to the fan discharge for volume control.

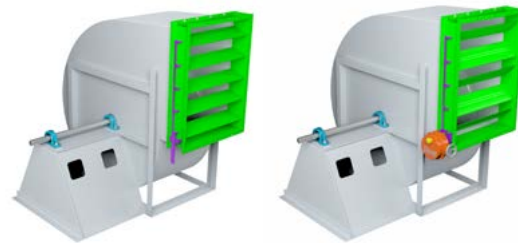

6. **Shaft Cooler** — Also referred to as “heat slingers” or “cooling wheels,” these are small, radially bladed aluminum wheels that are split and bolted for installation between the inboard bearing and fan housing. The cooling fins face the bearing for grease applications and away from the bearing for oil applications to prevent oil from being drawn out of the bearing.



7. **Anti-Rotation Clutch** — Damage will occur if the fan is operated in the wrong rotation. Run the motor uncoupled from the fan to establish the proper rotation.

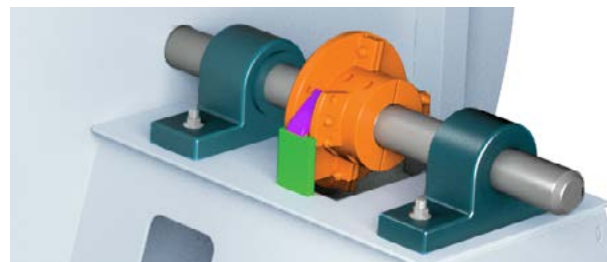

8. Oil Lubrication:

Static Oil – Warning: Some fans are supplied with oil lubricated anti-friction bearings due to customer preference. Some fans are supplied with oil as the fan speed exceeds that which is acceptable for grease. Consult with the factory before changing lubrication from oil to grease.

- a. Use non-detergent turbine oil specified on the fan's general assembly drawing.
- b. Oil level should be half way up the bottom rolling element. If leakage occurs, lower the oil level by 2-3 mm.
- c. A breather should be used to equalize pressure, which reduces oil leakage.
- d. If a heat slinger is supplied, place vanes facing away from the bearing to prevent oil from being drawn out of the bearing.
- e. Change oil regularly if automatic oilers are not being used. Oil condition depends upon operating temperature, hours of operation, moisture, environmental cleanliness and overall vibration. Start at three month intervals and adjust interval based on the condition of the used oil. Clean the breather at this time.
- f. If removing the bearing cap, prior to reinstalling, clean the splits and apply a thin coat of Permatex in order to minimize leakage.
- g. Set up automatic lubricators according to instructions supplied with the fan.
- h. Prior to start-up, be sure that the oil has been heated to a minimum of approximately 50° F.



Static Oil
Lubrication System

OPTIONAL ACCESSORIES (CONT.)

Oil Circulation Systems:

- a. Use non-detergent, turbine grade oil specified on the general accessory drawing.
- b. Utilize the drain ports specified on the general accessory drawing.
- c. There must be a slope of 15 degrees or 1/2" slope per foot to effectively drain the bearing and minimize leakage.
- d. Drain lines should be vented at the highest point above the bearing centerline.
- e. Piping must be flushed to leave no residue on a 20 micron filter.
- f. Return piping should be heat traced to maintain flow in cold conditions.
- g. Minimum fan-start oil temperature to be 70° F.
- h. Maintain 110-130° F inlet oil temperature during operation.
- i. If a heat slinger is supplied, place vanes facing away from the bearing to prevent oil from being drawn out of the bearing.
- j. Oil flow must be established by measuring quantity vs time (gpm) at the bearing drain. Too much oil flow can cause unwanted leakage. Oil flow rate is found on the general assembly drawing.

9. **Site-Feed Oilers** — Fans provided with optional, site-feed oilers, the oil level is to be set as indicated by the manufacturer's installation instructions provided with the fan.

10. Concrete Filled Bases:

Inertia Bases – Inertia bases are spring isolated bases specifically designed to be filled with concrete (by others). The following instructions are a guide for filling a base with concrete. Remember to use safe practices when filling concrete into the base. It is best to fill concrete at or near the base's final resting area to reduce injury while transferring to the permanent location.

An inertia base is supplied with steel mesh or rebar added within the base frame with the intent of being filled with concrete and then mounted on springs. Bases may be supplied with or without an optional bottom pan (sealer sheet).

When an optional bottom pan is supplied from the factory, the base must be set on a flat, level surface with the bottom pan directly on the surface fully supporting the pan to maintain flatness on the bottom side. Pour concrete into the base and remove excess concrete on the top side of the base to maintain an even mounting surface for fan mounting. Be sure that the concrete has cured before lifting the base. Install isolators per the isolator installation manual.

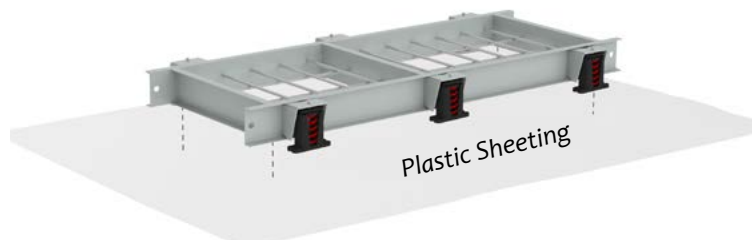

When the optional bottom pan is not supplied, the base must be set on a flat, level surface that can fully support the weight of the concrete. Place a sheet of heavy-mil poly-film between the flat surface and the base frame. Pour concrete into the base and remove excess concrete on the top side of the base to maintain an even mounting surface for fan mounting. Be sure that the concrete has cured before lifting the base. Install isolators per the isolator installation manual.

OPTIONAL ACCESSORIES (CONT.)

Unitary Bases – Unitary bases are rigidly mounted to a foundation. Situations may arise where the base may require concrete to dampen vibration or increased stiffness. In situations where concrete must be added to the base the following guide must be utilized.

1. Rebar must be added to the cross section of the base (by others) so the concrete will have good adhesion points throughout the sections of the base. Typically rebar is installed at 12" centers however the placement of rebar should be reviewed for each individual application by a Civil Engineer if required.
2. Bases should be located in their final resting area prior to being filled with concrete. Bases should be shimmed and grouted. Once the grout is cured, concrete may be added. Pour concrete (by others) into the base and remove excess concrete on the top side of the base to maintain an even mounting surface for fan mounting.

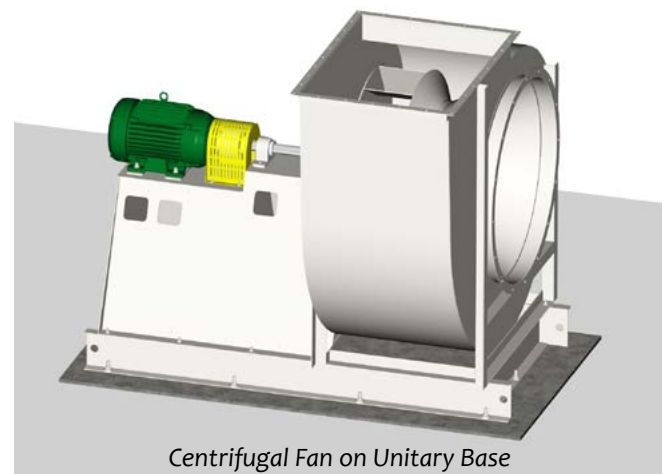

Centrifugal Fan on Unitary Base



CLICK TO VIEW OUR
UNITARY BASE INSTALLATION VIDEO

11. **Concrete Filled Pedestals** — Fans may require the bearing and/or motor pedestals to be filled with concrete (by others) for additional stiffness and rigidity, refer to the fan's drawing for requirements. Fans must utilize rebar in the pedestals so the concrete will have good adhesion points throughout.

To fill the pedestal, the pedestal must be set on flat, level ground before concrete is added. It is recommended to locate the fan at the final location. The fan should be leveled, shimmed and grouted prior to adding concrete.

An optional bottom pan is available for the pedestal if it is unfeasible to add concrete at the final location. Pedestals must be placed on the ground for filling until the concrete cures. If no bottom pan is provided, a piece of plywood covered in plastic may be placed under the base while filling with concrete. Fill the pedestal with concrete (by others) to the level indicated on the drawings. After the concrete cures the fan may be installed. Do not utilize the fan's lifting lugs after concrete has been added to the fan. The lifting lugs are designed to lift the fan as it was shipped from the factory.

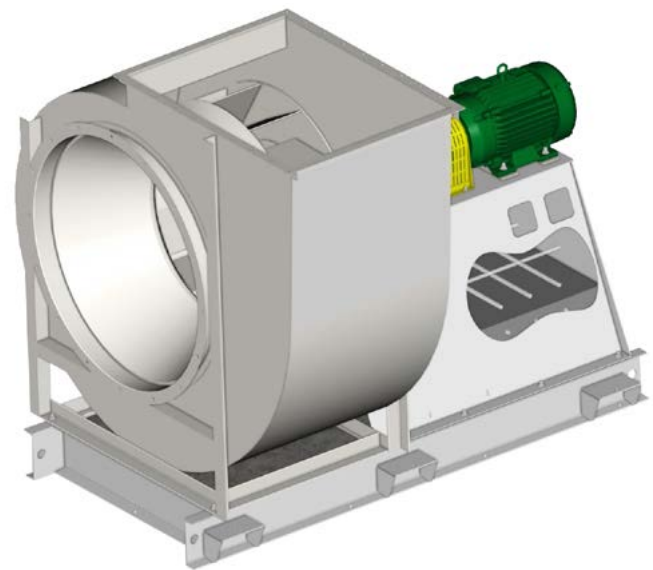

NOTICE

Concrete cure time varies depending on the base size, ambient temperature and cement mixture requested. Be sure concrete is 100% cured prior to moving equipment.

GROUTING

Grouting is the final installation step. If Aerovent service is purchased, grouting must be delayed until after the Aerovent inspection and vibration check. Check all shims before grouting to make sure that the fan is resting evenly on all points with anchor bolts secured to hold the shim. Back off leveling nuts if used. Use forms with sufficient space allowed for working the grout. The concrete foundation should be clean and well moistened before pouring grout. Use a commercial grade nonshrinking grout and be especially sure when pouring grout that the anchor bolt sleeves are filled. Prior to grouting, set a section of pipe (conduit, steel pipe or plastic) through the grout as a form in the low point which is able to wick/drain out the excess moisture. Refer to the Foundations and Supporting Structures section in the installation manual for a detail of a proper foundation, grout allowance and anchor bolt sleeves.

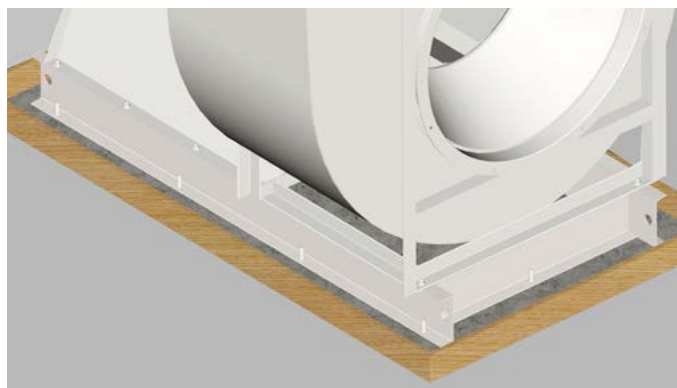

SERIAL NUMBER & FAN TYPE

The serial number and fan type can be found on our permanent nameplate of the fan.

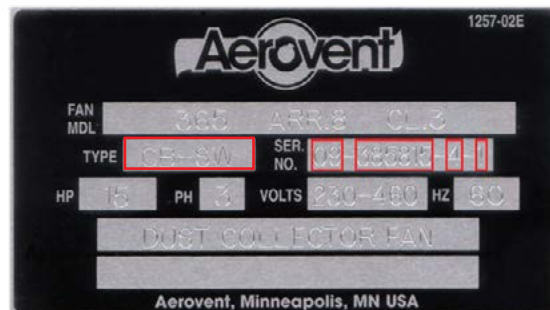

WHEEL PLACEMENT

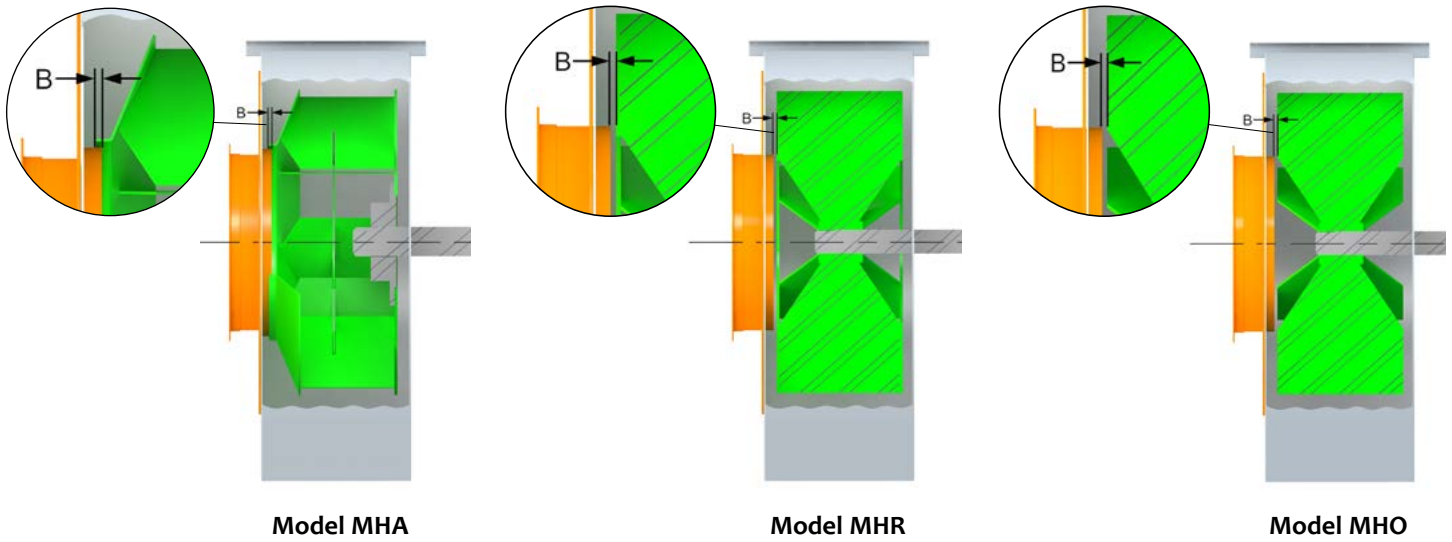

MHA Wheel Overlap																		
Size	907	909	911	913	915	917	919	921	923	926	929	933	937	941	945	949	954	960
B	0.25	0.38	0.47	0.53	0.59	0.69	0.69	0.0	0.0	0.0	0.0	0.0	0.0	0.0	0.0	0.0	0.0	0.0

MHO, MHR Wheel Gap															
Size	913	915	917	919	921	923	926	929	933	937	941	945	949	954	960
B	0.53	0.53	0.59	0.69	0.78	0.88	0.97	1.03	1.22	1.38	1.56	1.69	1.81	1.88	2.16

Note: On Sizes 905-911 MHO and MHR wheel is to be centered in housing.

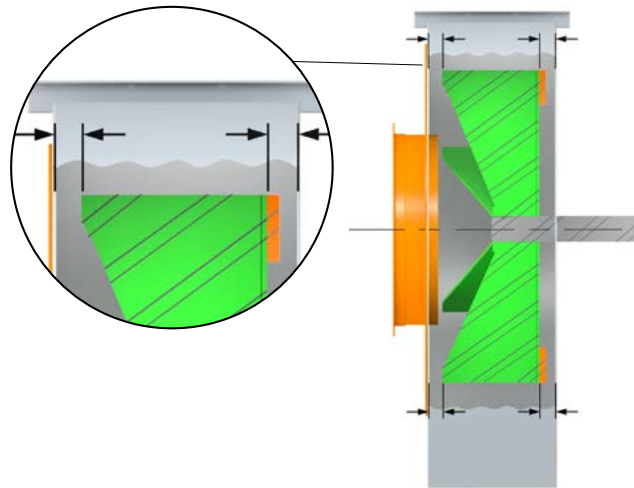

Models MHW, MHP

MHW, MHP Wheel Placement
Center wheel in housing. Do not include the backplate fins for centering.

WHEEL PLACEMENT

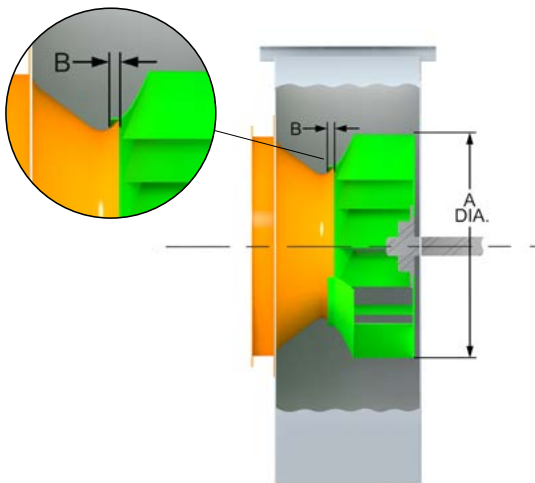

Models CB-SW, CBA-SW, CAE-SW, BIUB, BAUB

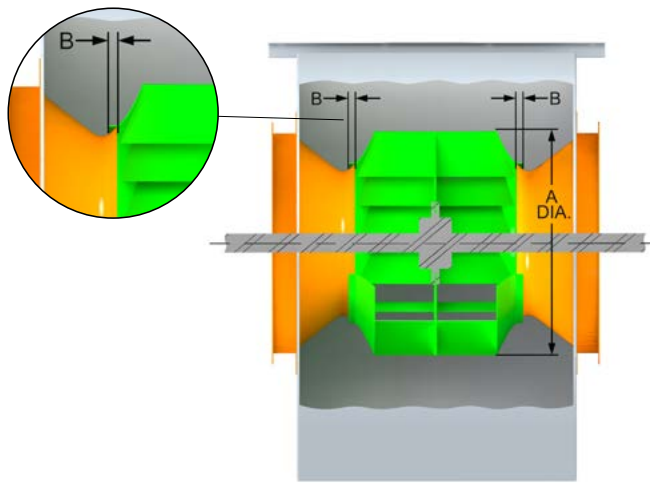

Models CB-DW, CBA-DW, CAE-DW

CB-SW, CB-DW, CBA SWSI & DWDI, BIUB (Class I & II) Wheel Overlap																						
Size	105	122	135	150	165	182	200	222	245	270	300	330	365	402	445	490	542	600	660	730	807	890
A	10.50	12.25	13.50	15.00	16.50	18.25	20.00	22.25	24.50	27.00	30.00	33.00	36.50	40.25	44.50	49.00	54.25	60.00	66.00	73.00	80.75	89.00
B	0.28	0.31	0.34	0.38	0.38	0.47	0.52	0.55	0.59	0.67	0.75	0.82	0.72	0.90	1.00	1.10	1.25	1.24	1.36	1.88	2.09	2.28

BAUB, CAE-SW & CAE-DW Wheel Overlap																						
Size	122	135	150	165	182	200	222	245	270	300	330	365	402	445	490	542	600	660	730	807	890	982
A	12.25	13.50	15.00	16.50	19.00	20.82	23.16	25.51	28.11	31.23	34.36	38.00	41.90	46.33	51.01	56.48	62.47	68.71	73.00	80.75	89.00	98.25
B	0.31	0.34	0.38	0.44	0.38	0.41	0.45	0.50	0.55	0.61	0.67	0.75	0.82	0.91	1.00	1.11	1.23	1.35	1.50	1.65	1.82	2.02

Note: On swingout fans, the wheel and funnel should be positioned as close as possible (max gap 1/8") such that the door can be opened without the wheel and funnel interfering.

BIUB (Class L) Wheel Overlap	
Size	B
090-105	0.28
122	0.31
135	0.34
150	0.38
165	0.44
182	0.56
200	0.63
222	0.69
245	0.75
270	0.88
300	0.97
330	1.06
365	1.31

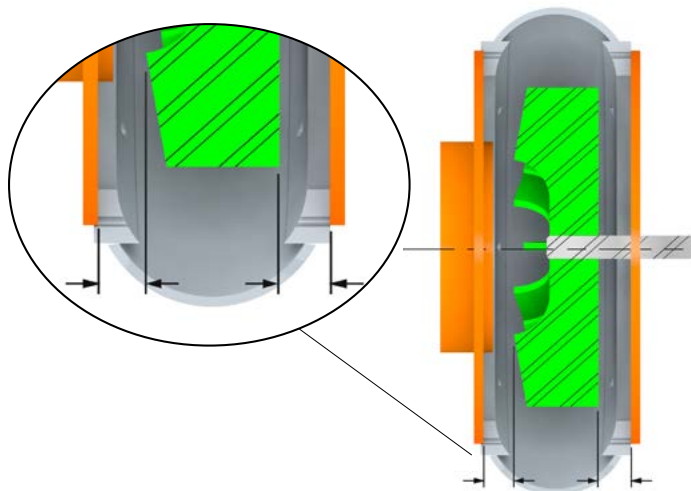

Model CPB



CPB Wheel Placement
Center wheel in housing.

WHEEL PLACEMENT

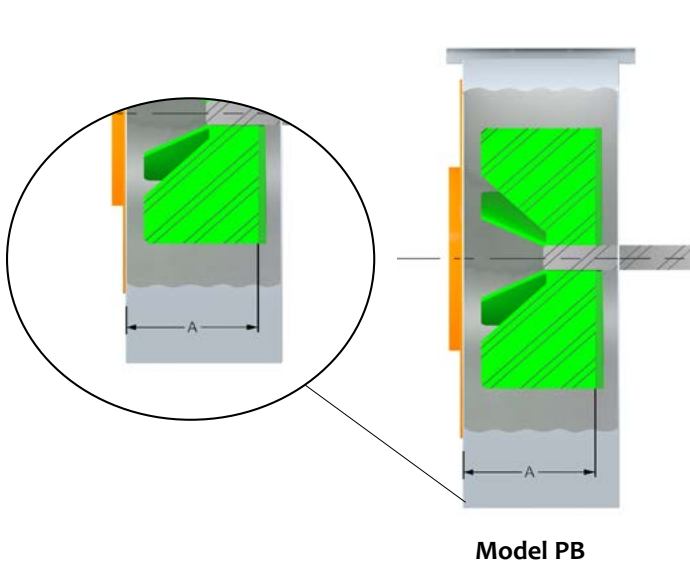

PB Wheel Placement	
Size	A
PB8A	2.8125
PB10A	2.8125
PB10B	4.75
PB12A	2.78125
PB12B	4.8125

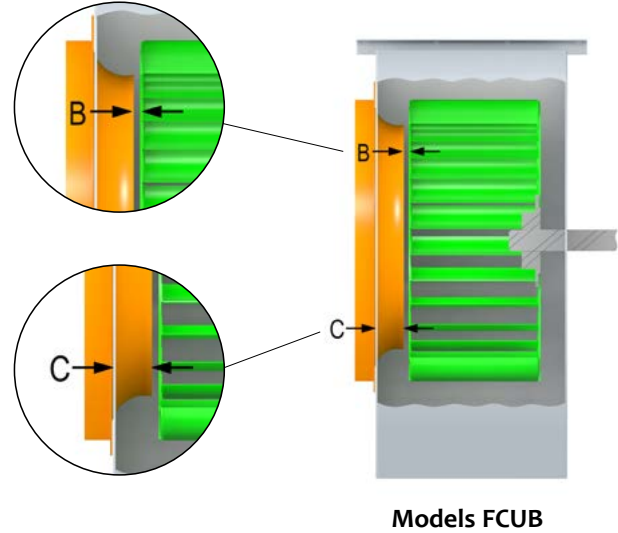

FCUB Wheel Gap					
Size	B	C	Size	B	C
10.5	0.47	0.69	30	0.75	4.38
12	0.25	1.88	33	0.81	5.00
15	0.44	2.19	36	0.75	5.00
18	0.50	2.25	39	1.06	6.38
21	0.69	2.88	42	1.69	7.50
24	0.81	3.00	48	1.50	7.13
27	0.69	3.13	54	1.00	10.50

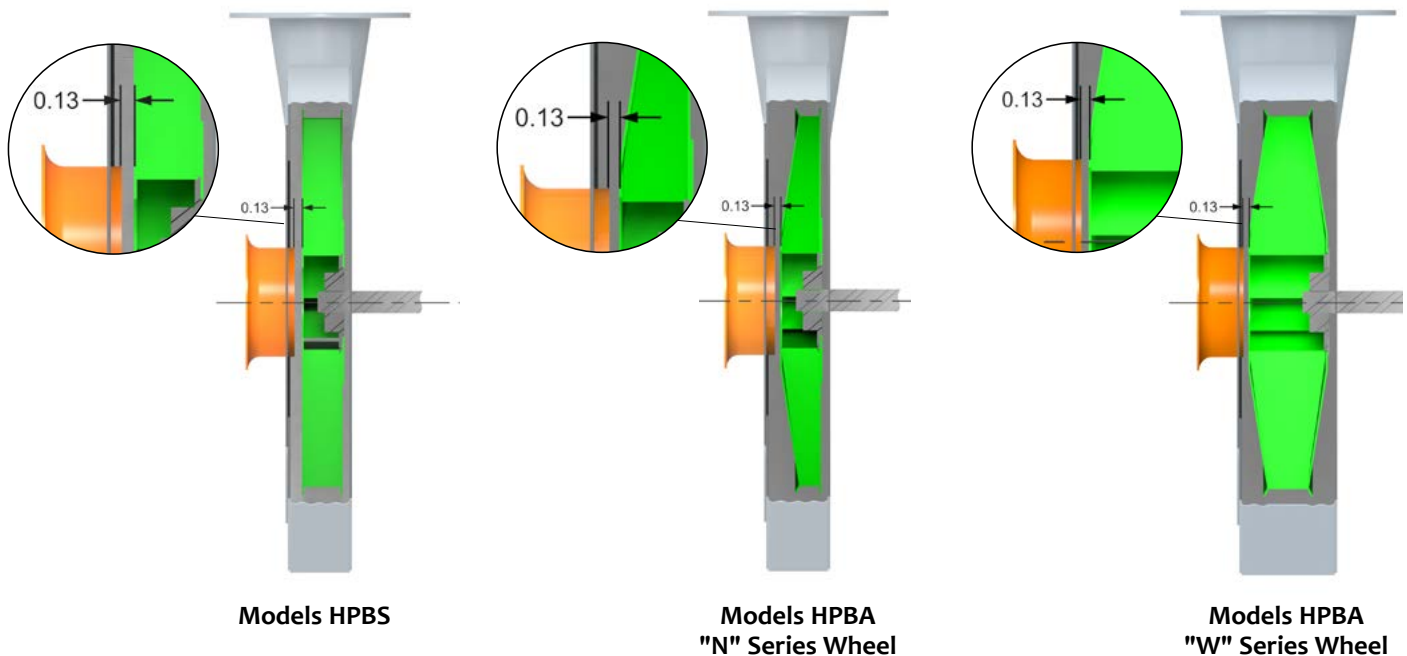

HPBA, HPBS Wheel Gap
0.13" gap on all sizes

WHEEL PLACEMENT

CA, CABD Wheel Placement		
Wheel Size	A	B
8" Housing / Width		
R7 X 2.44	0.58	3.14
R8 X 2.50	0.52	
9" Housing / Width		
R8 X 2.50	0.56	3.18
R8.5 X 2.75	0.30	
R9 X 2.88	0.19	
R9.75 X 2.88	0.31	
R10.63 X 2.63	0.46	
BC10.25 X 3	0.25	
10" Housing / Width		
R9 x 2.88	0.23	3.22
R9.75 x 2.88	0.35	
R10.63 x 2.63	0.50	
R11 x 2.75	0.28	
R11.5 x 2.88	0.27	
R12 x 2.88	0.23	
R12.25 x 2.88	0.21	
BC10.25 x 3	0.29	
BC11 x 3	0.29	
12" Housing / Width		
R10.63 x 2.63	1.22	3.94
R11 x 2.75	1.00	
R11.5 x 2.88	0.99	
R12 x 2.88	0.95	
R12.25 x 2.88	0.93	
R13 x 3.25	0.55	
R14 x 3.25	0.61	
BC11 x 3	1.01	
BC13 x 3.25	0.57	
BC14 x 3.25	0.57	
14" Housing / Width		
R12.25 x 2.88	1.59	4.60
R13 x 3.25	1.21	
R14 x 3.25	1.27	
R14.75 x 4	0.48	
BC13 x 3.25	1.23	
BC14 x 3.25	1.23	
15" Housing / Width		
R14 x 3.25	2.49	5.82
R15.5 x 5	0.70	
R16.5 x 4.38	1.37	
BC14 x 3.25	2.45	
BC15.5 x 5	0.81	
BC16.5 x 4.38	1.45	
18" Housing / Width		
R14 x 3.25	1.31	4.64
R16.5 x 4.38	0.19	
R18 x 4.38	0.36	
BC14 x 3.25	1.27	
BC16.5 x 4.38	0.27	
BC18 x 4.38	0.14	

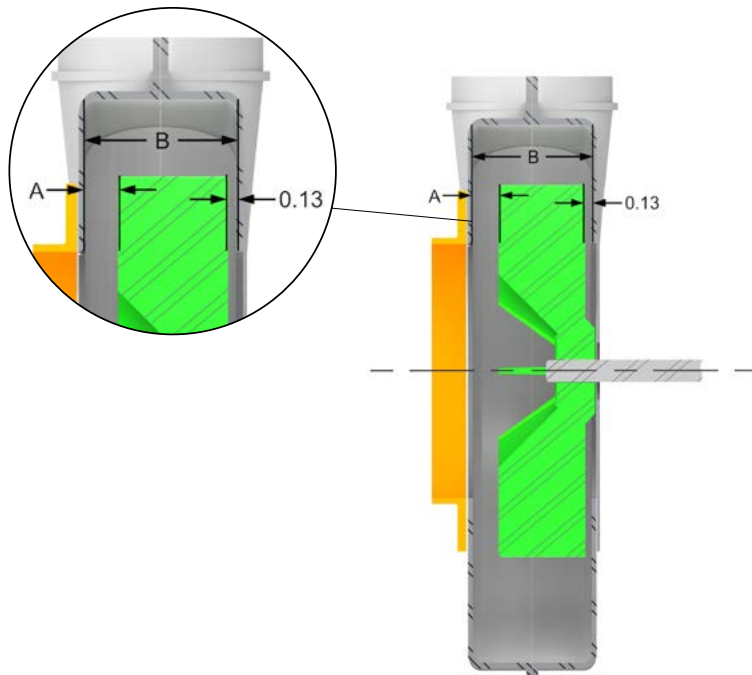

Model CA, CABD



TROUBLESHOOTING GUIDELINES

Use current safety practices when investigating fan or system performance problems. General safe practices and performance troubleshooting guidelines can be found in AMCA Publications 410 and 202, respectively. Fan application and field measurement procedures can be found in AMCA Publications 201 and 203.

Below is a list of possible areas to check when air or sound values do not match expectations. Most fan problems can be pinpointed to one of these common causes.

Air Capacity Problems

1. Resistance of the system is not at design rating. If resistance is lower than expected, both airflow and horsepower may be up. If resistance is higher than anticipated, air volume will be down.
2. Fan speed is not at design speed.
3. Air density is not at the design value. Also check air performance measurement techniques/procedures.
4. Devices for air modulation are closed or plugged. Also check filters.
5. Wheel mounted improperly or is rotating in reverse.
6. Parts of the system or fan have been damaged or need cleaning.

Noise Problems

1. Air performance is incorrect and the fan is not at design point of operation. Fan is being forced to operate in an unstable flow region near peak or to the left of the peak of the curve.
2. Bearing failure. Check bearings (lubrication).
3. Supply voltage high or inconsistent supply frequency. Adjustable frequency controllers can generate motor noise.
4. Objects which are installed in a high velocity airstream can generate noise. This includes flow sensors, turning vanes, etc.
5. Poor fan inlet conditions.
6. Acoustics or sound measurement procedure incorrect.

Vibration Problems

1. Misalignment of drive components. Check belt or coupling.
2. Poor foundation or mounting structure (resonances).
3. Foreign material attached to rotating components.
4. Damaged rotating components (bearings, shaft, fan, wheel, sheaves).
5. Broken, loose or missing setscrews.
6. Loose bolts.
7. Vibration transmitted by another source.
8. Water accumulating in airfoil blades.
9. Fan is operating in stall or unstable flow region.

Motor Problems

1. Incorrect wiring.
2. Speed of fan too high.
3. Parts improperly installed; binding.
4. Bearings improperly lubricated.
5. WR^2 capability of motor too low for application.
6. Protection devices may be improperly sized.
7. VFD compatible electrically? Effective shaft grounding?
8. Is cabling and grounding correct?

Drive Problems

1. Belts improperly tensioned.
2. Drive alignment is poor. Check belt or coupling.
3. Coupling lubrication.



NOTICE

Most fans manufactured by Aerovent are factory balanced prior to shipment. Certain high horsepower, large or unusual voltage fans, may not be run as an assembly due to power constraints, however the rotors have been dynamically balanced. Installation variables, handling and movement of the fan during shipment may cause the rotating assembly to shift. Balance should be checked once the fan is installed. If a final trim balance is required, it is the end user's responsibility to bring the fan back to factory specifications. Final trim balancing is not the responsibility of Aerovent. Refer to the Vibration Guidelines table below.

VIBRATION GUIDELINES

Condition	Fan Application Category	Rigidly Mounted mm/s (in./s)	Flexibly Mounted mm/s (in./s)
Start-up	BV-3	6.4 (0.25)	8.8 (0.35)
Alarm	BV-3	10.2 (0.40)	16.5 (0.65)
Shutdown	BV-3	12.7 (0.50)	17.8 (0.70)

Values shown are peak velocity, mm/s (inches/s), filter out.





INSTALLATION/START-UP CHECKLIST

Become familiar with the equipment by looking at the fan assembly drawing for special instructions and accessories.

INITIAL FAN CHECK

- Inspect fan for damage
- Check foundation, prepare for shims
- Shim fan shaft level to 0.002"/ft
- Are the bolts tight
- Check to see if the fan is distorted by the foundation and/or ductwork
Note: Applies to direct or isolation mount.
- Check fan interior for debris and standing water

Fan Wheel

- Wheel clearance checked
- Wheel overlap checked
- Fasteners tight
- Wheel rotates freely

Springs (if equipped)

- Springs adjusted properly
- Flex joints allow movement
- Electrical conduit allows movement

Bearings

- Bearings aligned
- Bearings greased
Note: Rotate while greasing
- Setscrews tight (if equipped)

Lube Lines

- Lube lines been charged with grease prior to connecting to bearings

V-Belts (if equipped)

- V-belt drives aligned
- Sheaves retightened
- Belt tension correct
- Motor bolts retightened

Couplings (if equipped)

- Coupling aligned
- Coupling gap checked
- Coupling lubricated

Accessories

- Guards installed correctly, do not rub
- VIV/damper rotates freely (if equipped)
- Other accessories per drawing

WARNING



Verify that proper safety precautions have been followed.
Electrical power must be locked off.

ELECTRICAL COMPONENTS

- Motor wired for proper voltage and starter
- Motor grounded
- Appropriate starter and heaters
- Leads are properly insulated
- Accessories wired per instructions supplied

ENERGIZE

- Energize motor long enough to start assembly rotating, shut down
- Verify direction of wheel rotation, Rewire if necessary
Note: Refer to wheel rotation section
- Run the fan up to speed
- Check for excess vibration and listen for unusual noise. Refer to the Vibration Guidelines table in the troubleshooting guidelines section for vibration limits
- Proceed to grout
- Bearing temperatures should stabilize after a few hours. Less than 200°F
Note: Use sense of smell to identify possible electrical, belt issues.

AFTER ONE WEEK

- Verify bolt tightness
- Verify belt tension and adjust as necessary

NOTICE

Always observe site specific and regulatory safety precautions.

SERIAL NUMBER: _____

COMPLETED BY: _____

DATE COMPLETED: _____



FAN MAINTENANCE LOG

Model Number _____

Serial Number _____

Date	Completed Maintenance	Performed By	Comments



FAN MAINTENANCE LOG

Model Number _____

Serial Number _____

Date	Completed Maintenance	Performed By	Comments



WWW.AEROVENT.COM

5959 TRENTON LANE N | MINNEAPOLIS, MN 55442 | PHONE: 763-551-7500 | FAX: 763-551-7501

©2017 - 2020 AEROVENT