

FUME HOOD EXHAUST FANS

Model AFE

Fume Hood Exhaust Fans

Fume hood exhaust fans manufactured by Aerovent are the ideal choice for successfully removing undesirable fumes and gases from laboratory hoods, kitchen hoods, process operations, foundry operations and many other applications. Fume hood exhaust fans are not intended as substitutes for proper pollution control equipment, but rather a means to exhaust low concentrations of potentially toxic fumes out of and away from occupied spaces.

With Aerovent's fume hood exhaust fans, the technology of high velocity and high dilution discharge can be applied to a variety of our standard air moving products, with many sizes to choose from, in direct drive or belt driven units. These choices exist in a broad line of AMCA certified, high quality air moving equipment.

Typical applications include research/development, petrochemical, pharmaceutical, hospital/medical, biotech, industrial processes, and school and university laboratories.

Criteria for Selecting Fume Hood Exhaust Fans

There are many site-specific factors that affect the discharge profile and dispersion of rooftop exhaust systems. Some of the factors that must be considered are:

- Prevailing wind direction and speed
- Building height
- Nearby buildings and terrain
- Exhaust discharge height and velocity
- Other roof structures
- Location of air intakes

ASHRAE recommends that a building profile study of the site be conducted to determine how these factors will affect the design of the fume exhaust system.

In addition, local and national codes and various agencies and trade associations have established some general guidelines for fume hood exhaust fans.

1. ASHRAE recommends a minimum of 2500 FPM discharge velocity, and a minimum of 84" discharge height. (ASHRAE Handbook-Fundamentals, 1993 CH14 & NFPA Std. 45, 1991)
2. ANSI/AIHA recommends a minimum discharge velocity of 3000 FPM and minimum discharge height of 120" above the roof line. (ANSI/AIHA Std. Z9.5, 1992)

It is the intent of these recommendations that the fans discharge in a manner and location to avoid reentry of exhaust fumes into the building or adjacent buildings. To achieve a suitable discharge velocity, nozzles are bolted either to the fan outlet or to the top of the stack.

Variety of Mounting Arrangements

It is often desirable to keep a constant volume (velocity) at the discharge of the fan allowing the operator of the fume hood to vary the opening area and volume of air the hood exhausts. There are three methods usually used to achieve this:

1. **Hood Bypass** — As the fume hood is closed, a bypass normally located at the top of the hood opens to allow room air to be vented.
2. **Common Plenum** — Large low pressure fans exhaust a mixture of exhaust fumes and outside air from a common plenum or manifold. The flow rate at the hoods is controlled either by variable speed exhaust or dampers in the hood discharge duct.
3. **Single Fan Bypass** — High velocity upblast exhaust fans for each hood are mounted on a damped outside air bypass box which opens when the hood sash is closed.

Aerovent can provide fume hood exhaust fans for any of the above mentioned arrangements.

Special Selection Criteria For Perchloric Acid Exhaust Applications

Exhaust fans handling perchloric acid fumes require special considerations. Perchloric acid is very corrosive and is potentially unstable. For these reasons, Aerovent recommends, as a minimum, that the fans used in perchloric acid applications be supplied with the following accessories:

- AMCA "B" spark resistant construction
- Inlet flange
- Discharge flange
- Stainless steel spray nozzle in fan inlet
- Oversize drain connection
- Special coating on all airstream parts: Teflon, Kynar (Dykor) or other suitable coating
- Explosion proof motor

NOTE: The duct system may require additional spray nozzles and drains for complete washdown.

Other applications, such as biological agents and radioactive material, may also require special consideration. Consult your local Aerovent sales representative for assistance.

Tubular Centrifugal Inline Fans

Model AFE incorporates a straight-line centrifugal flow fan. This fan has the reliable performance of a centrifugal fan with the space saving advantages of an axial type fan. Because of a recent redesign of the product, the new AFE has many improvements. The AFE has a higher and broader efficiency range compared to competitive tubular fans and square inline fans. Higher efficiency allows for lower operating speed at a given performance. This, in turn, leads to lower sound levels, longer life span and more reliable operation. With its extra wide blades, the unique wheel design allows a larger volume of air to flow with a minimum of turbulence losses. Additionally, repositioning of bearings and drive components increases the bearing life. A removable discharge cone facilitates maintenance and service. Applications with larger motors feature a pivot-style motor base for ease of belt tension adjustments.



Wheel

The AFE Tubular Centrifugal Fan employs a specially designed non-overloading airfoil wheel. In a tubular centrifugal fan, the air turns 90° after leaving the wheel. Aerovent's unique wheel design with open back plate (patent #5,171,128) allows this turn to be made with a minimum of turbulence loss. Also, the extra wide blade design helps deliver a larger air volume for a given wheel diameter. The AFE wheel improves overall efficiency and reduces sound levels.



AFE Fume Hood Inline Exhaust Fans

Standard Product Features

- Backward inclined flat and airfoil wheel designs
- Wheel diameters from 12" through 30". Partial width wheels for size 12" are used for low airflow requirements.
- Discharge venturi cap
- Heavy duty coated steel curb cap
- Access door
- Shaft seal
- Weather cover

Optional Features

- Stack between fan and discharge venturi cap
- Galvanized heavy-duty curb cap
- Mixing box with bypass damper
- AMCA "A", "B" or "C" spark resistant construction
- Special coatings
- Special materials of construction
- Isolation Dampers
- Contact factory for common mixing plenum boxes
- Hinged weather cover

The AFE fan consists of a vertically mounted inline centrifugal fan with a reinforced curb cap and a modified discharge cap. The discharge cap includes an outlet venturi to permit the outlet velocity to meet the specific roof exhaust requirements. AFE fans in a standard configuration utilize an extended discharge with optional stack extensions available. The heavy-duty curb cap will permit stack extensions up to 10 feet (120 inches) total height from the roof line without the need for guide wires.

For AFE performance, please use Aerovent's Fan Selection Program or contact your nearest Aerovent representative for assistance.



AFE Dimensional Data

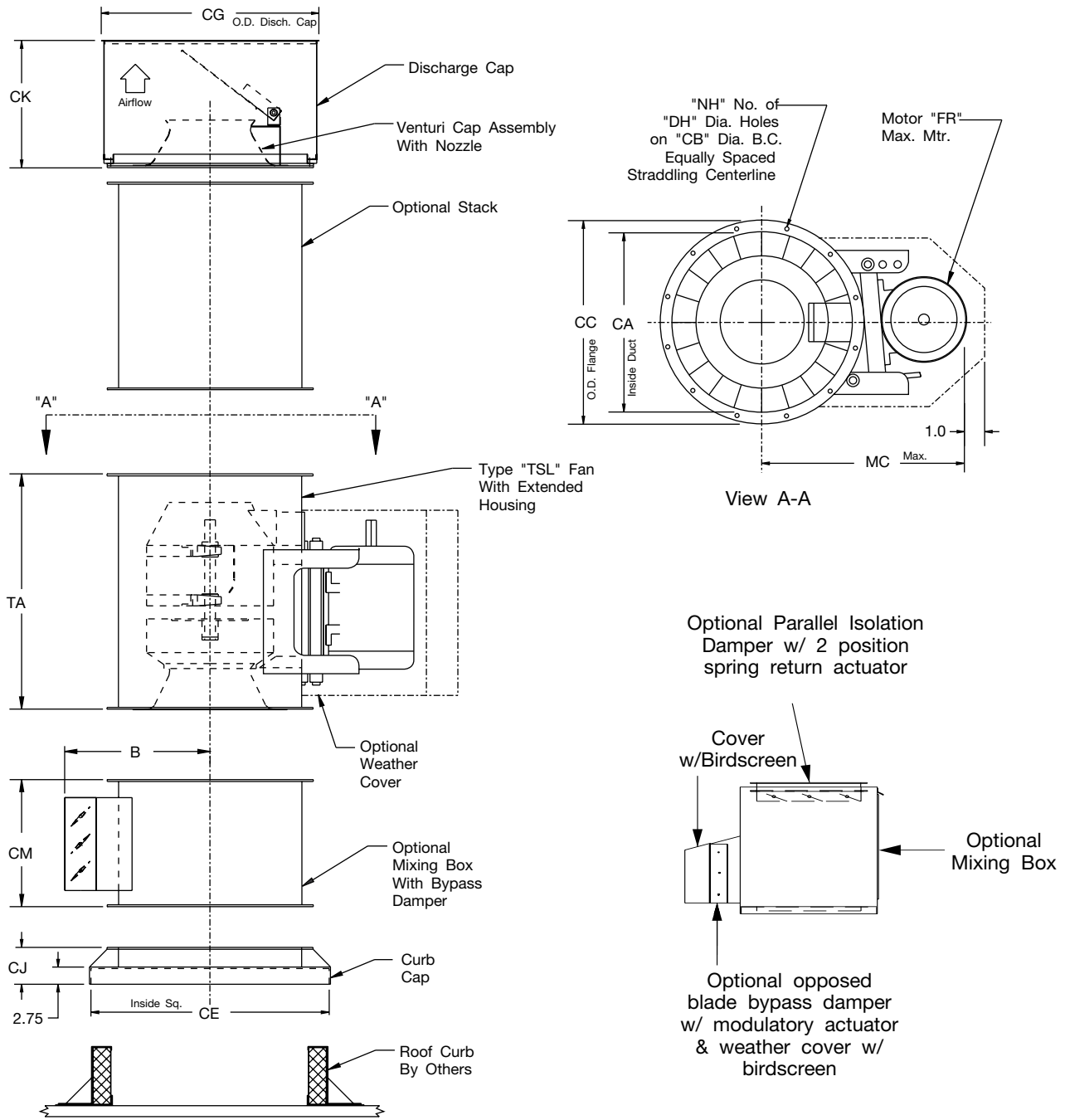

SIZE	B	CA	CB	CC	CE	CG	CJ	CK	CM	DH	FR	MC	NH	TA
122	18.38	16.56	18.50	19.75	23.75	29.00	5.50	19.25	16.50	0.56	184T	23.13	8	31.25
150	20.13	20.25	22.13	23.38	27.38	33.00	6.00	22.50	20.25	0.56	215T	25.75	8	35.75
182	22.38	24.69	26.75	28.00	34.88	37.00	6.63	27.00	24.75	0.69	256T	34.44	12	37.25
200	23.63	27.06	29.13	30.31	37.38	40.00	6.75	29.50	27.00	0.81	256T	36.25	12	40.50
222	25.13	30.06	32.13	33.38	40.38	43.00	6.75	32.50	30.00	0.81	256T	39.19	12	44.50
245	26.63	33.13	35.13	36.38	43.38	46.00	7.00	35.50	33.25	0.81	365T	43.63	12	49.75
270	28.25	36.50	38.50	39.75	46.75	50.00	7.25	38.75	36.50	0.81	365T	46.44	12	53.25
300	30.38	40.56	43.13	44.88	51.00	53.00	7.75	42.50	40.50	0.81	365T	49.38	16	58.50

AFE Typical Specifications

Type AFE Fume Hood Exhaust Fans, where indicated on drawings and schedules, shall be of the non-overloading design, and shall be of the size and capacity as indicated in the fan schedule. Fume hood exhaust fans shall be as manufactured by Aerovent, Minneapolis, Minnesota.

The ratings shown are based on tests and procedures performed in accordance with AMCA Standard 210-74 for air moving devices. Fans shall have a sharply rising pressure characteristic extending through the operating range and continuing to rise well beyond the efficiency peak to assure quiet and stable operation under all conditions. Horsepower characteristics shall be truly self-limiting and shall reach a peak in the normal selection area.

WHEELS — Wheel diameters shall be in accordance with the standard sizes adopted by AMCA Standard 2411-69 for centrifugal tubular type fans. Fan wheel sizes 182 and larger shall have die-formed airfoil blades designed for maximum efficiency and quiet operation. The wheel shall be specifically designed for inline fans to offer a higher and broader efficiency range. The backplate of the wheel shall be designed to offer lower resistance to the air leaving the wheel. Wheels shall be statically and dynamically balanced and the complete fan assembly shall be test balanced at or near operating speed at the factory prior to shipment.

HOUSINGS — Housings shall be cylindrical welded steel throughout and suitably braced to prevent vibration or pulsation. Fan inlets shall be deep spun, fully streamlined, heavy cones. Airfoil blades shall be continuously welded to the backplate and wheel cone. Housings shall be equipped with a bolted access door for inspection and cleaning of the wheel, and a shaft seal where the shaft passes through the inner cylinder.

SHAFT & BEARINGS — Bearings are to be ball or roller anti-friction type, and shall be equipped with extended lubrication lines with grease fittings outside of the fan housing. Shafts shall operate at least 30% below first critical speed to assure smooth operation.

CURB CAP — A heavy-duty, coated steel or galvanized curb cap shall be included to provide for a weathertight transition between the roof curb and the fan. The curb cap shall allow discharge height up to 10 feet from roof without the need for guy wire support.

DISCHARGE CAP — A venturi type discharge cap shall be provided to efficiently increase discharge velocities to between 2500 and 3000 FPM without significantly affecting BHP requirements. The venturi discharge shall be covered by a hinged cap to provide a tight seal when the fan is not operating and shall be guarded by an encircling wind band. An extended stack between the fan and discharge cap shall be included to provide a minimum discharge height of between 84" and 120" from roof surface.

WEATHER COVER — A raintight, easily removable weather cover shall be provided to completely enclose the motor and exposed parts of the V-belt drive.

OPTIONAL ACCESSORIES — Where required the fans shall be provided with:

- AMCA A, B, or C Spark Resistant Construction
- Disconnect Switches
- Hinged Access Door
- Wheel Backplate Fins
- Mixing Box with Bypass Damper
- Special Coatings (Epoxy, Heresite, Eisenheiss) on airstream parts or entire unit

SUBMITTALS — Submittals for approval of equipment shall include copies of outline drawings, AMCA Certified Ratings and percentage pressure-volume performance curves showing point of operation.



Additional Fume Hood Exhaust Fans

AMX Mixed Flow Fan

Mixed flow fans are becoming a popular choice on many air supply, return, general and grease-laden exhaust and laboratory exhaust applications in the HVAC industry for both constant or variable air volume systems. The efficiency and sound characteristics of the mixed flow fans are often desired in buildings such as hospitals, libraries, theaters, and general offices. The Aerovent heavy-duty construction of AMX fans also make them suitable for many industrial applications handling ambient air. Applications involving fumes, spray booth exhaust, particulate, heavy moisture content, or high temperature should be discussed with the factory for possible product modifications.

For AMX mixed flow performance, use AMX Bulletin 330 performance tables.



PB Pressure Blower

Pressure blowers provide medium pressure air for cooling, ventilating and exhaust systems handling dust, materials or corrosive fumes. Pressure blowers feature direct drive or belt driven models, wheel diameters from 8" through 12", flow capacities to 1275 CFM, static pressure to 10" w.g. and temperature to 600°F (with modifications).

For PB fume hood exhaust performance, use PB Bulletin 904 performance tables.

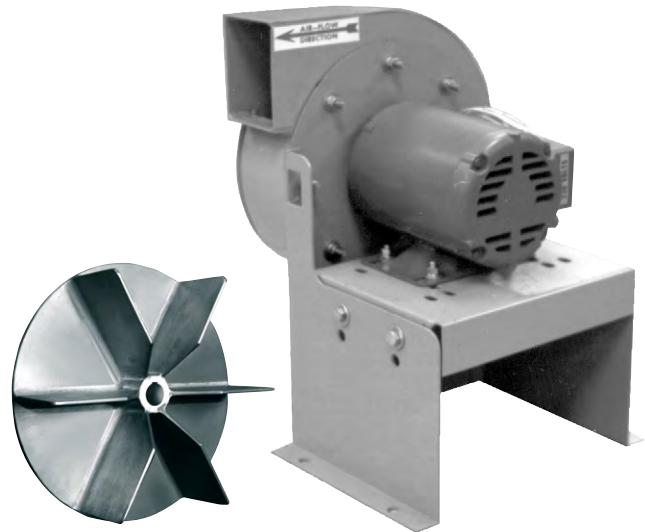

©2009 Twin City Fan Companies, Ltd., Aerovent. All rights reserved throughout the world.

Bulletin illustrations cover the general appearance of Aerovent products at the time of publication and we reserve the right to make changes in design and construction at any time without notice.

Additional Fume Hood Exhaust Fans

BIUB

Type BIUB fans utilize a backward inclined non-overloading wheel in aluminum or steel construction. The Arrangement 10 "vent set" configuration provides an efficient, compact, weatherproof, rooftop exhaust fan assembly and is available in Class I or II. It is shown here with an optional, space-saving, integral curb base-inlet box. Aerovent's BIUB fan is a rugged and versatile choice for a wide range of laboratory fume hood applications.

See Bulletin 760C for BIUB fan performance tables.



CA Cast Aluminum Blower

Aerovent's Cast Aluminum Pressure Blowers are the perfect choice for providing low volume, high pressure air for cooling, ventilating and exhaust systems which handle dust, materials or corrosive fumes. These direct drive (CA) or belt driven (CABD) blowers feature heavy duty cast aluminum housings with cast aluminum wheels for extra long life and trouble-free service.

For cast aluminum blower performance, use CA Bulletin 916 performance tables.

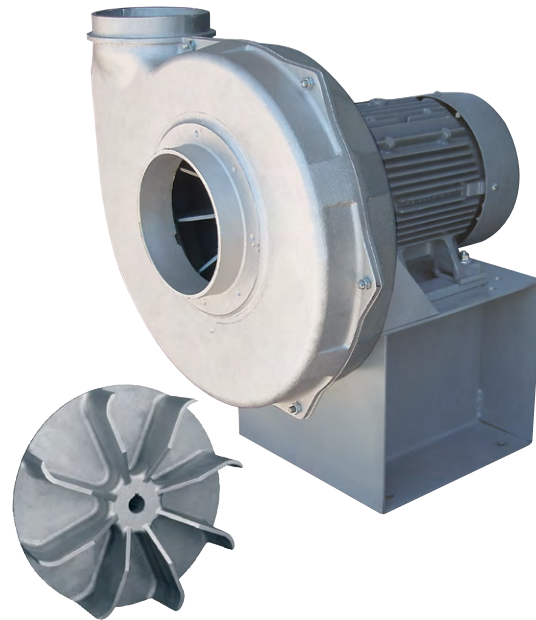

**PROPELLER FANS | TUBEAXIAL & VANEAXIAL FANS | CENTRIFUGAL FANS & BLOWERS | ROOF VENTILATORS
INDUSTRIAL AIR HANDLERS | AIR MAKE-UP | FIBERGLASS FANS | CUSTOM FANS**



AEROVENT
A Twin City Fan Company

AEROVENT 
INDUSTRIAL VENTILATION SYSTEMS

WWW.AEROVENT.COM

5959 Trenton Lane N | Minneapolis, MN 55442 | Phone: 763-551-7500 | Fax: 763-551-7501