

MIXED FLOW FANS



MODELS: AMX / AMXR / AMXSH





Arr. 9
Model AMX with
Horizontal Support Legs

Models AMX is available with the UL/cUL 705 listing for electrical, File No. E158680.



Model AMXR is UL/cUL 705 Supplement SC (formerly cULus 762) listed for the exhaust of grease-laden air as standard, File No. MH-25478.

Model AMXSH is UL/cUL listed for Smoke Control Systems as standard, File No. MH-29313, 500°F for 4 hours and 1000°F for 15 minutes.



Aerovent, a Twin City Fan Company, certifies that the Model AMX, AMXR, AMXSH Mixed Flow Fans shown herein are licensed to bear the AMCA Seal. Certified performance data may be found in Aerovent's Fan Selector software.



Scan the QR code to search Aerovent's AMCA-certified products.

Overview

AMX | AMXR | AMXSH

Benefits of Mixed Flow Fans

Aerovent Model AMX Mixed Flow Fan combines the benefits of axial flow and centrifugal flow fans. The AMX has the advantage of the compact design and straight-through airflow as well as the preferred acoustic characteristics and high pressure capability. AMX fans offer superior air and sound performance and the AMCA certified rating seal for air and sound.

Typical Applications Include

Data Center Exhaust, General HVAC, Generator Room Ventilation, Swimming Pool Exhaust, Kitchen Exhaust, Dishwasher Exhaust, Elevator Shaft Exhaust/Pressurization, Emergency Smoke Exhaust, Stairwell Pressurization

Arrangements

Available in Arrangement 4, Direct Drive (AMX) and Arrangement 9, Belt Driven (AMX, AMXR, AMXSH)

Impeller Type

Mixed Flow Airfoil

Optional Construction

Clamshell Design, Swingout Design, Special Materials, Fume Hood Design, Spark Resistant, UL 705, UL 705 Supplement SC (formerly UL 762), UL Smoke and Heat

Certifications

AMCA Sound/Air and FEI, UL 705 Listed for Electrical, Listed for Grease-Laden Air, UL Listed for Smoke Control Systems

Energy Regulations

Aerovent supports energy efficiency regulations enacted by the Department of Energy (DOE) and energy commissions of specific states. The selection and application of fan products is a significant part of these regulations. Engineers and specifiers must understand how to apply Aerovent products to their specific applications to meet efficiency requirements. Aerovent has made significant investments in product testing to assure users will receive the most efficient products available. Developments in the Fan Selector software are in place to help aid in product selection to meet the efficiency requirements as stipulated in the regulations. Visit aerovent.com for the latest on fan energy efficiency regulations.

Overview

AMX | AMXR | AMXSH

Product Applications

Mixed flow fans are becoming a popular choice on many air supply, return, general and grease-laden exhaust and laboratory exhaust applications in the HVAC industry for both constant or variable air volume systems. The efficiency and sound characteristics of the mixed flow fans are often desired in buildings such as hospitals, libraries, theaters and general offices. The heavy-duty construction of AMX fans also makes them suitable for many industrial applications handling ambient air. Applications involving fumes, spray booth exhaust, particulate, heavy moisture content or high temperature should be discussed with the factory for possible product modifications.

General HVAC Fans

AMX

18.25" to 89" impeller diameters
Airflow to 160,000 CFM
Static pressure to 8" w.g.



Restaurant Fans

AMXR

18.25" to 89" impeller diameters
Airflow to 160,000 CFM
Static pressure to 8" w.g.



Smoke & Heat Fans

AMXSH

18.25" to 89" impeller diameters
Airflow to 160,000 CFM
Static pressure to 8" w.g.



Temperature Rating

500°F for 4 Hours
1000°F for 15 Minutes



For complete product performance, drawings and available accessories, download our Fan Selector software at aerovent.com.



General HVAC (Model AMX)

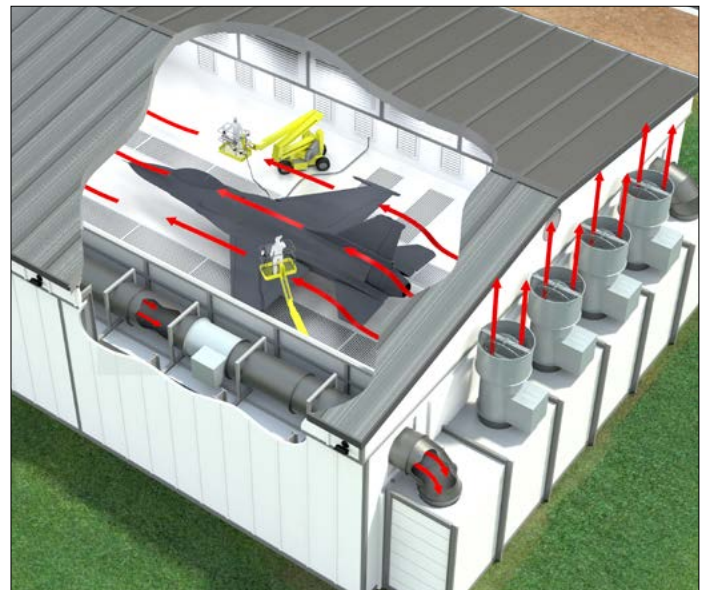

Paintbooth Application (Model AMX)

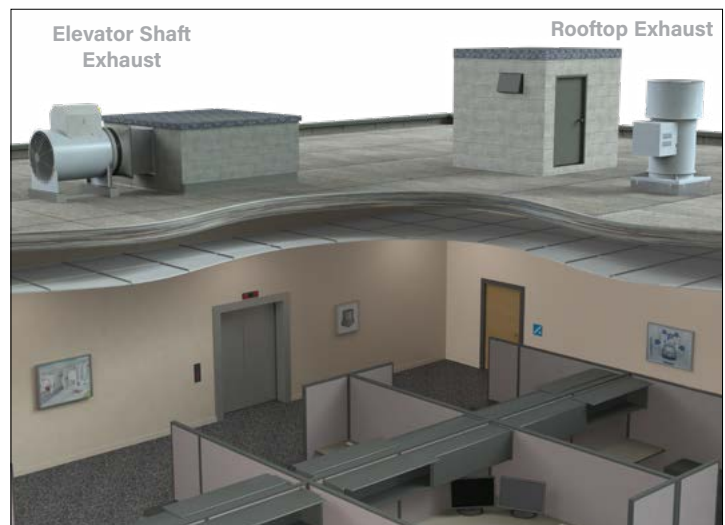

Emergency Smoke Control (Model AMXSH)

Model AMX



General HVAC

Model AMX is available in both direct drive and belt driven. The AMX mounts both vertically and horizontally, allowing for numerous applications with multiple mounting arrangements. Sizes range from 150 - 730 and performance ranges from 1,300 - 160,000 CFM. Model AMX is UL/cUL 705 listed.

Ultra Quiet

The AMCA Certified Ratings for Air and Sound applies to both inlet and outlet sound power levels. The table below displays sound and static efficiency differences between performance points for a comparable tubular centrifugal fan and a vaneaxial fan.

PERFORMANCE	SIZE	SOUND LwA (dB)		
		AMX Mixed Flow Fan	TSL Inline Centrifugal Fan	VPBD Vaneaxial Fan
5000 CFM @ 1" SP	AMX 245	72	77	79
10000 CFM @ 1" SP	AMX 330	72	81	82
25000 CFM @ 3" SP	AMX 402	86	92	98
50000 CFM @ 6" SP	AMX 490	95	102	112

Models

AMXR | AMXSH



AMXR Restaurant Fans (Belt Driven Only)

Aerovent offers a specially modified version of the AMX fan designated as "AMXR" (Mixed Flow Restaurant Exhaust) for exhausting grease-laden air from kitchens, restaurants, cooking and dishwasher hoods. AMXR is available in sizes 150 through 730.

Model AMXR is cULus 705 Supplement SC (formerly UL 762) listed for exhaust of grease-laden air. AMXR is licensed to bear the AMCA certified ratings seal for sound and air performance.

The AMXR fan is available in all configurations with the exception of vertical down (VDN, VDO and VDI).

Standard Product Features

- Belt guard, totally enclosed, ventilated (weather cover for VRM)
- Belt tube, sealed
- Two cleanout doors located 180° apart (90° from motor)
- 2" drain located 180° from motor (lowest point for horizontal) vertical at the funnel
- Cooling fins on impeller
- Housing sealed with Hi-Temp caulk



AMXSH Smoke & Heat Fans (Belt Driven Only)

Aerovent offers a specially modified version of the AMX fan designated as "AMXSH" (Mixed Flow Smoke and Heat Exhaust) for smoke control applications where temperatures can reach 1000°F. AMXSH is available in sizes 150 through 730.

Model AMXSH is cULus 705 listed and cULus listed for smoke control systems for 500°F for 4 hours or 1000°F for 15 minutes. Vertical roof mounted configuration, with stack cap, meets UL 793 Snow Load Test requirements for butterfly dampers. AMXSH is licensed to bear the AMCA certified ratings seal for sound and air performance.

The AMXSH fan is available in all configurations with the exception of vertical down (VDN, VDO and VDI).

Standard Product Features

- Belt guard, ventilated (weather cover for VRM)
- Belt tube, sealed
- Two-groove drive minimum with 2.0 SF
- Cooling fins on impeller
- Stack cap with fusible link (for VRM)
- Continuously-welded housing

Housings

All fans are constructed of heavy-gauge steel and continuously-welded for strength and rigidity. All AMX fans are provided with punched inlet and outlet flanges as standard.

Impeller

The AMX impeller is designed with true airfoil (double surface - hollow) die-formed, continuously-welded blades for a stable air performance throughout the operating range. The impeller is statically and dynamically balanced prior to assembly and rechecked for balance after assembly by Aerovent.



AMX Impeller

Belt Guard

Totally enclosed, sealed belt guard is standard on Model AMX. Totally enclosed, non-sealed belt guard is standard on Models AMXR and AMXSH.

Inner Cylinder

The inner tube is rigidly constructed to support the shaft and bearings. The removable discharge cone provides full access to the shaft, bearings and fan sheave. It is strongly recommended that an access door be provided in the ductwork adjacent to the discharge end of the fan for such service.

Bearings

Standard bearings are selected to exceed the L-10 life of 40,000 hours at the maximum operating speed.

Drives

V-belt drives or direct drive fans with motors and drives mounted by Aerovent are test run as a complete assembly and rechecked for balance.

Straightening Vanes

Straightening vanes convert tangential velocity pressure into useful static pressure, reducing turbulence and increasing efficiency. Extensive testing of various shapes and locations has resulted in the most efficient aerodynamic design of the straightening vanes.

Motor Mounting Platform

A heavy-duty motor mounting platform pivots to offer easy and positive adjustment of belt tension. The motor mounting platform is offered in eight standard locations to allow for motor accessibility and space requirements.

Shaft

Shaft diameter sized so that maximum operating speed does not exceed 70% of first critical speed.

Optional Construction

Spark Resistant Construction

Fan applications may involve the handling of fumes or vapors. Such applications require careful consideration by the system designer to insure the safe handling of such gases. Aerovent offers the following classifications of spark resistant construction per AMCA Standard 99-0401. It is the specifier's or the user's responsibility to specify the type of spark resistant construction with full recognition of the potential hazards and the degree of protection required.

Type A - All parts of the fan in contact with the airstream must be made of nonferrous material — usually aluminum and limited to 200°F.

Type B - The fan shall have a nonferrous impeller and nonferrous rub ring about the opening through which the shaft passes — usually aluminum impeller and rub ring and limited to 200°F. Consult factory for availability.

Type C - The fan is constructed so that a shift of the impeller or shaft will not permit two ferrous parts of the fan to rub or strike.

Additional Options

- Clamshell and Swingout Construction (see page 7)
- Fume Hood Design (see page 7)
- UL 705

Swingout Construction

Provides full access to the impeller and inner casing. The entire impeller/shaft/bearing assembly is mounted on a large swingout door. Ideal for systems requiring frequent cleaning without removal of ductwork. Swingout construction is available for vertical mounting only. Available on sizes 222 through 445.



Clamshell Construction (Single & Double Door)

Clamshell construction is ideal for applications needing regular cleaning. Depending on the size, one door (sizes 122-270) or two doors (sizes 300-445) are secured with quick access latches. These doors open outward and allow access to the internal components of the fan. As standard, there is an access door on the inner cylinder, allowing easy access to clean around the bearings. It is essential to follow proper safety precautions during cleaning. If bearing, shaft or impeller replacement is required, the fan should be removed from the ductwork or roof to facilitate safe replacement of parts. If replacement of these parts while ducted or on the roof is required, it is recommended to use swingout construction.

Accessories and Options

- Steel, aluminum and stainless steel construction available.
- FRP plastic inlet funnels available when aluminum is not suitable for spark resistant construction.
- Removable bearing cover plate is standard on axial swingout fans.
- Special coatings are available for corrosion resistance.
- OSHA belt guard available for all swingout and clamshell fans.



Fume Hood Exhaust Design

Aerovent offers a specially modified version of the AMX fan designated as "AFE" for laboratory fume hood exhaust applications, available in sizes 90 through 542. The Model AFE fan consists of a vertically mounted mixed flow fan with a reinforced curb cap and a modified stack cap. The stack cap includes an outlet venturi to permit the outlet velocity to meet the specific roof exhaust requirements. Model AFE fans in a standard configuration utilize an extended discharge with optional stack extensions available. The heavy-duty curb cap will permit stack extensions for outlet height of 10 feet (120 inches) from the roof line without need for guide wires.

Refer to Catalog 390 for selection and specifications.



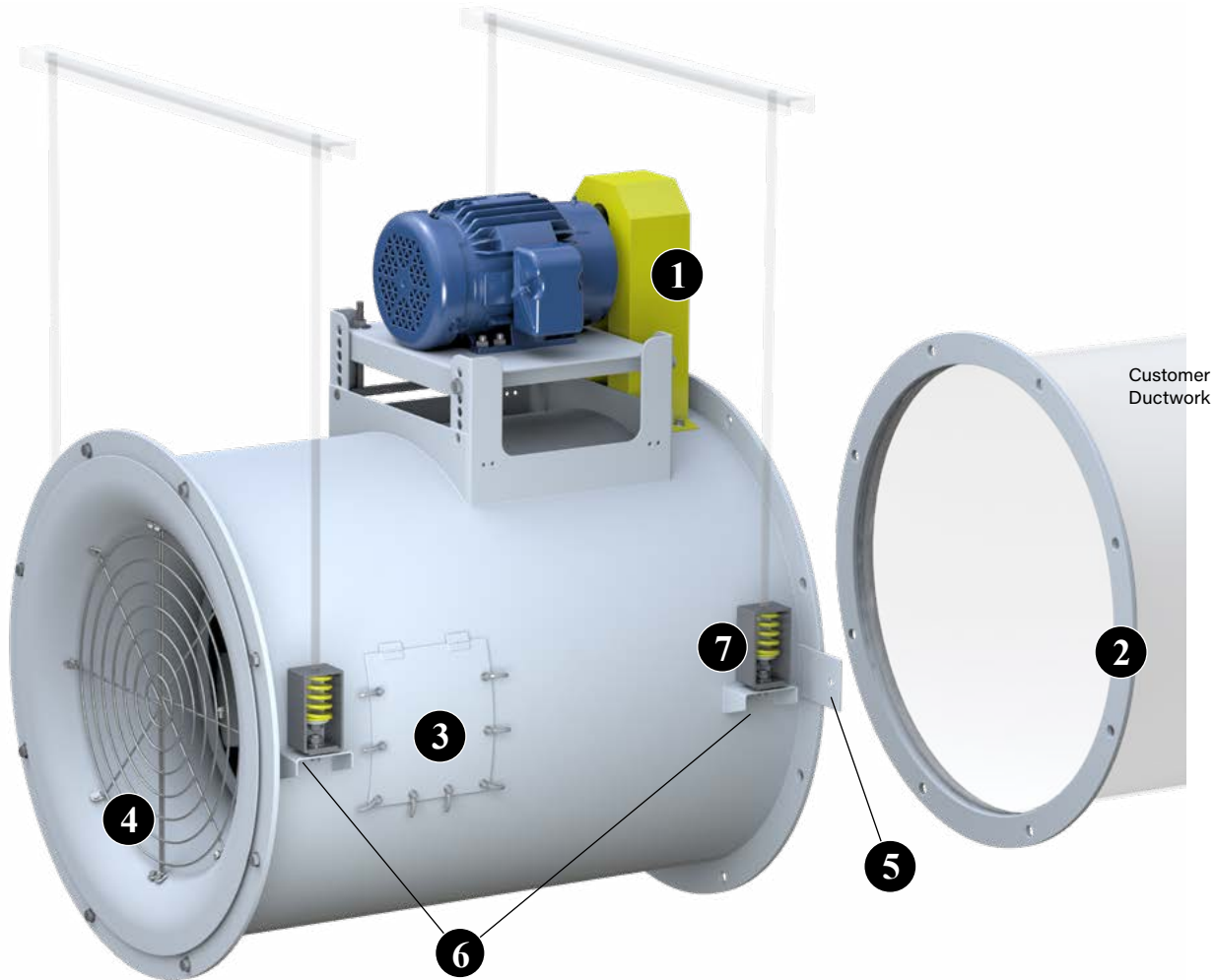

- 1 Belt Guard** Available in Arrangement 9 belt driven fans, the belt guard encloses the motor sheave and V-belts. The guard is easily removable for inspection and maintenance.
- 2 Companion Flanges** Flanges are rolled angle rings, drilled to match the fan's inlet or outlet flange.
- 3 Quick Open Access Door** For quick impeller inspection and maintenance. Access doors are specified where examination and cleaning of the fan interior is required. A bolted access door is also available.
- 4 Safety Screen** Safety screening can be provided for installation in the fan inlet, fan outlet.
- 5 Thrust Restraints** Steel brackets located near the outlet to mount thrust restraint isolators (supplied by others).
- 6 Suspension Clips** For horizontal flow with ceiling mounting, four clips of formed angle are welded to the fan housing for suspension via tie rods to the ceiling support structure.
- 7 Vibration Isolators** Spring type vibration isolation mounts are available to reduce the transmission of fan vibration in 1" or 2" deflection. Rubber-in-shear isolators are also available as an option.

Other Accessories Include:

- Hinged Weather Cover
- Insulated Roof Curb
- Magnetic Damper Latches
- Vertical Support Legs
- Piezometer Ring
- Horizontal Support Legs
- Pressure Transducers
- Insulated Enclosure
- Shaft Seal

- 1 **Stack Cap** Stack caps are designed for vertical, rooftop discharge with butterfly type dampers to seal out the weather when the fan is shut off.
- 2 **Weather Cover** For outdoor installations, the weather cover completely encloses the motor and V-belt drive from the elements. Provided with slots for ventilation. Weather covers are available for either horizontal or vertical flow fans.
- 3 **Curb Cap** Attached to the fan's inlet flange for curb mounting; used on vertical roof mounted configuration.
- 4 **Grease Box** The heavy-gauge galvanized grease box is designed to trap the grease in and allow the water to run off onto the roof.
- 5 **Vented Roof Curb** Self-flashing style curbs with ventilation louvers allow ambient air in to cool and dilute grease- or smoke-laden airstreams. (See page 10 for additional curb options.)
- 6 **Extended Copper Lube Lines** Lube lines with grease fittings are extended to the outside of the fan housing. Nylon lube lines are standard on Model AMX. Copper lube lines are standard construction on Models AMXR and AMXSH.
- 7 **NEMA 3R Disconnect Switch** AMX fans are provided with a NEMA 3R rain-tight disconnect switch, externally mounted when ODP or TEFC motors are used. Switch is available shipped loose for field mounting and wiring or factory mounted and wired.
- 8 **NEMA 4 Disconnect Switch** A NEMA 4 disconnect switch is mounted externally and is water and dust-tight. Switch is available shipped loose for field mounting and wiring or factory mounted and wired. (See page 11 for additional disconnect switch options.)

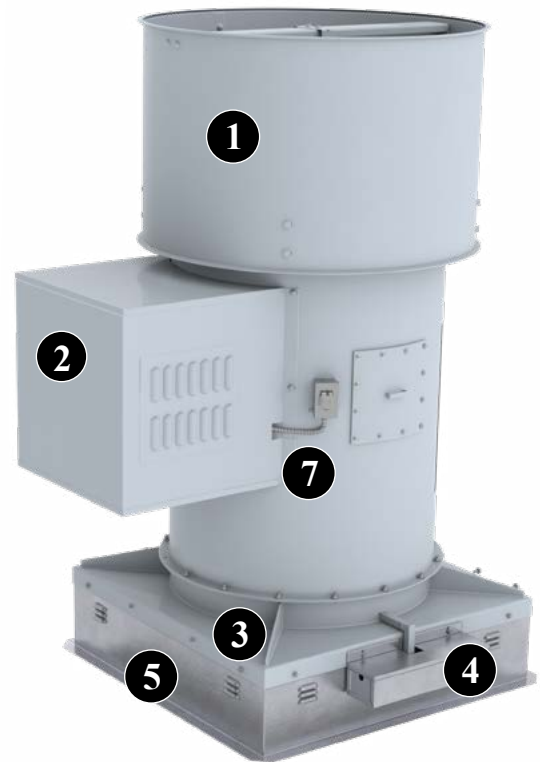

Model AMXR
(Restaurant Fan)

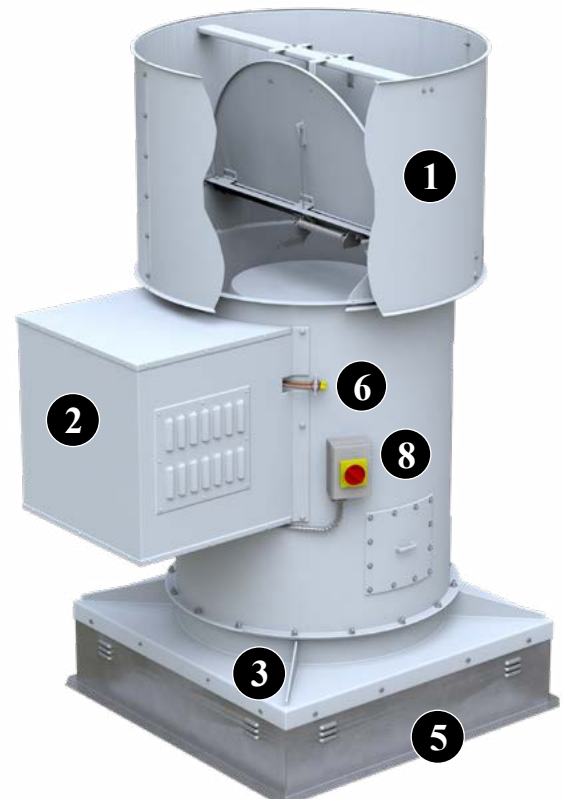

Model AMXSH
(Smoke & Heat Fan)

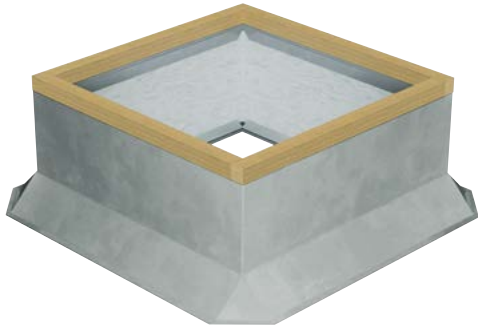

Canted Roof Curbs

- Constructed of 18-gauge galvanized steel with continuously-welded seams
- Large 3" built-in 45° cant to accommodate roofing material to top of curb. Cant is beveled at corners for better support of roofing material
- Wood nailer (1½") secured to top ledge
- Lined with 1½" fiberglass fire-resistant, sound-absorbing insulation
- Damper shelf standard
- Not available on Models AMXR and AMXSH
- Options: Aluminum (16-gauge) construction, burglar security bars, metal liner (galvanized or aluminum), special heights up to 24", single- or double-pitched curbs for sloping roofs



Self-Flashing & Straight Sided Roof Curbs

- Constructed of 18-gauge galvanized steel with continuously-welded seams
- Wide base plate (flashing) to insure watertight seal to roof
- Top ledge covered with 3/16" polystyrene gasket for weather seal and to reduce metal-to-metal conducted noise
- Lined with 1½" fiberglass fire-resistant, sound-absorbing insulation
- Damper shelf standard
- Straight-sided roof curbs are constructed with the same features as the self-flashing curbs, but are sized smaller to allow for field supplied cants and roofing material to be brought up to the top of the curb
- Not available on Models AMXR and AMXSH
- Options: Aluminum (16-gauge) construction, burglar security bars, metal liner (galvanized or aluminum), special heights up to 24", wood nailer (1½") secured to top ledge in lieu of polystyrene gasket, single- or double-pitched curbs for sloping roofs



Self-Flashing Vented Roof Curbs

For High Temperature Applications

- Completely assembled unit, easier to install and less expensive than a field constructed curb
- Constructed of 18-gauge galvanized steel with continuous welded seams and wide base flashing for watertight seal to roof
- Meets NFPA-96 code requirements
- Top ledge covered with 3/16" polystyrene gasket
- Furnished with ventilation slots



Curb Adapters

- Constructed of heavy-gauge galvanized steel with continuously-welded seams
- Top ledge covered with 3/16" polystyrene gasket to reduce metal-to-metal conducted noise and act as a weather seal
- Available in enlarger or reducer (shown) models

Disconnect switches provide positive electrical shutoff during fan cleaning or maintenance.

NEMA 1 Disconnect Switch

A NEMA 1 disconnect switch is available shipped loose for field mounting and wiring or factory mounted and wired with ODP or TEFC motors. For indoor applications.

NEMA 3R Disconnect Switch

A NEMA 3R, rain proof, disconnect is available shipped loose for field mounting and wiring or factory mounted and wired externally.

NEMA 4 Disconnect Switch

A NEMA 4, water and dust tight, disconnect is available shipped loose for field mounting and wiring or factory mounted and wired externally.

NEMA 7/9 Disconnect Switch

A NEMA 7/9 disconnect switch is recommended on fans with explosion proof motors. The NEMA 7/9 switch is designed for use with fans operating in hazardous environments. Available shipped loose for field mounting and wiring. (Not shown.)



NEMA 1
Disconnect Switch



NEMA 3R
Disconnect Switch



NEMA 4
Disconnect Switch



Installation Photos



Biofilter Exhaust



Paint Spray Booth



General HVAC

Arrangements & Mounting Configurations



FAN SIZE	ARR. 3 OVERALL LENGTH (TA)	LENGTH SAVINGS (IN.)
182	26.75	7.13
200	28.81	8.38
222	30.88	9.25
245	33.94	10.38
270	36.50	12.31
300	40.88	13.69
330	44.94	14.94
365	49.44	16.94
402	54.31	18.69
445	59.06	21.88
490	64.06	24.94
542	71.38	27.38



Arrangement 4 (Direct Drive)

The arrangement 4 AMX is constructed with the fan impeller mounted directly on the motor shaft, this fan provides premium efficiency with minimal obstructions in the airstream. Only available on Model AMX.

Arrangement 3

Where space is a premium, the AMX Arrangement 3 is available to shorten the overall fan length. The table above shows the overall savings in length versus an Arrangement 9 fan. Consult factory for further information.



Arrangement 9 (Belt Driven)

Designed for mounting the motor on outside of casing in one of the standard locations shown below. For horizontal and vertical discharge.

Mounting Configurations

Horizontal Construction

Horizontal construction is available in sizes 150 through 730.

Horizontal Base Mounted (HBM) — Support legs are provided at each end of the fan for floor mounting.

Horizontal Ceiling Hung (HCH) — For duct mounted fans, four suspension clips are welded to the fan casing to allow ceiling suspension using rod hangers.

Horizontal (HOR) — For mounting configurations where support legs and suspension clips are not required.

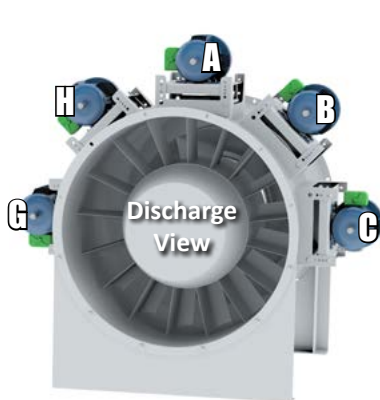
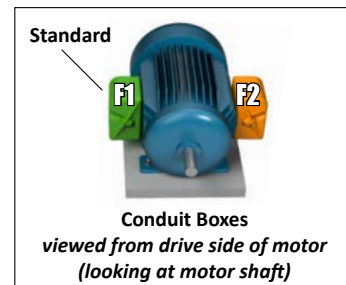

HBM
*Horizontal
Base Mounted*

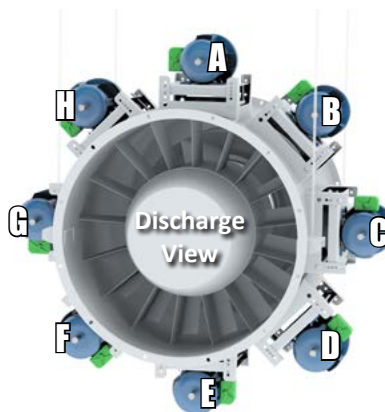

HCH
*Horizontal
Ceiling Hung*



HOR
*Horizontal
No Mounting
Brackets*

Vertical Construction

Vertical construction is available in sizes 150 through 542. Consult factory for larger sizes.

Floor or Ceiling Mounted (VUI/VUO/VDI/VDO) — Four vertical brackets are welded to either end of the fan housing. Bracket location is determined by airflow direction and support details (see below).

Roof Mounted (VRM) — A curb cap provides weathertight seal for roof curb mounted fans. A stack cap and weather cover are also available for the upblast style roof ventilator.

Vertical (VUN/VDN) — For mounting configurations where support brackets are not required.

Available Discharges by Model

AMX	AMXSH	AMXR
HBM	HBM	HBM
HCH	HCH	HCH
HOR	HOR	HOR
VDI	N/A	N/A
VDN	N/A	N/A
VDO	N/A	N/A
VUI	VUI	VUI
VUN	VUN	VUN
VUO	VUO	VUO
VRM	VRM	VRM



VRM
Vertical Roof Mounted



VUI
Vertical Discharge Up, Floor Mount Support Brackets On Inlet



VUO
Vertical Discharge Up, Ceiling Hung Support Brackets On Outlet



VUN
Vertical Up No Brackets



VDI
Vertical Discharge Down, Ceiling Hung Support Brackets On Inlet



VDO
Vertical Discharge Down, Floor Mount Support Brackets On Outlet



VDN
Vertical Down No Brackets

Table 1. Maximum RPM, Impeller Weights, and WR^2 (moment of inertia in lb-ft²)

FAN SIZE	CLASS I			CLASS II		
	MAX. RPM	WEIGHT LB	WR ² LB-FT ²	MAX. RPM	WEIGHT LB	WR ² LB-FT ²
150	2721	24	5.5	3558	28	7.1
165	2483	32	8.0	3247	36	10.3
182	2232	38	12	2918	44	15
200	2027	48	20	2650	52	23
222	1839	57	29	2405	62	34
245	1655	69	45	2165	75	52
270	1505	82	66	1968	90	76
300	1360	140	133	1779	150	145
330	1234	167	197	1613	179	215
365	1116	233	320	1459	247	347
402	1013	324	588	1325	324	588
445	915	393	883	1197	393	883
490	828	478	1321	1082	478	1321
542	752	591	1934	984	591	1934
600	680	715	2893	890	715	2893
660	615	867	4334	804	867	4334
730	558	1064	6396	730	1064	6396

Table 2. Bare Fan Weights (lb)

FAN SIZE	ARRANGEMENT 9	
	CLASS I	CLASS II
150	168	175
165	202	210
182	215	227
200	257	267
222	303	315
245	367	377
270	434	450
300	660	690
330	802	821
365	1019	1048
402	1332	1357
445	1595	1627
490	1992	2008
542	2504	2537
600	3006	3034
660	3880	3979
730	4719	4758

Table 3. Temperature and Altitude Density Ratios

AIR TEMP °F	ALTITUDE IN FEET ABOVE SEA LEVEL											
	0	1000	2000	3000	4000	5000	6000	7000	8000	9000	10000	15000
	BAROMETRIC PRESSURE IN INCHES OF MERCURY											
	29.92	28.86	27.82	26.82	25.84	24.9	23.98	23.09	22.22	21.39	20.58	16.89
-50	1.293	1.247	1.201	1.159	1.116	1.076	1.036	0.997	0.960	0.924	0.889	0.729
0	1.152	1.111	1.071	1.032	0.995	0.959	0.923	0.889	0.856	0.824	0.792	0.650
70	1.000	0.964	0.930	0.896	0.864	0.832	0.801	0.772	0.743	0.714	0.688	0.564
100	0.946	0.912	0.880	0.848	0.818	0.787	0.758	0.730	0.703	0.676	0.651	0.534
150	0.869	0.838	0.808	0.770	0.751	0.723	0.696	0.671	0.646	0.620	0.598	0.490
200	0.803	0.774	0.747	0.720	0.694	0.668	0.643	0.620	0.596	0.573	0.552	0.453

Table 4. Bearing Specifications

FAN SIZE	CLASS I			CLASS II		
	SHAFT DIA. (IN.)	HORIZ.	VERT.	SHAFT DIA. (IN.)	HORIZ.	VERT.
150	1.000	SDB	SDB	1.187	SDB	SDB
165	1.000	SDB	SDB	1.437	SDB	SDB
182	1.000	SDB	SDB	1.437	HDB	HDB
200	1.187	SDB	SDB	1.437	HDB	HDB
222	1.187	SDB	SDB	1.437	HDB	HDB
245	1.437	SDB	SDB	1.687	HDB	HDB
270	1.437	SDB	SDB	1.687	HDB	RB
300	1.437	HDB	HDB	1.937	HDB	RB
330	1.687	HDB	HDB	2.187	HDB	RB
365	1.937	HDB	HDB	2.187	RB	RB
402	1.937	HDB	RB	2.187	RB	RB
445	1.937	HDB	RB	2.437	RB	RB
490	2.187	HDB	RB	2.437	RB	RB
542	2.437	HDB	RB	2.687	RB	RB
600	2.687	HDB	—	2.937	RB	—
660	2.937	HDB	—	3.437	RB	—
730	2.937	HDB	—	3.937	RB	—

NOTES:

- BEARINGS CODES:
 SDB — Standard-Duty Ball such as Dodge SCAH or SKF SY Series
 HDB — Heavy-Duty Ball such as Dodge SCMAH or SKF SYM Series
 RB — Roller Bearing such as Dodge S2000 or SKF SYR Series
- Standard bearings are selected to exceed L-10 life of 40,000 hours at the maximum operating speed.

Table 5. Minimum CFM Required to Open Stack Cap

FAN SIZE	CFM
150	1051
165	1707
182	2532
200	3527
222	3527
245	4693
270	6574
300	7605
330	8712
365	11158
402	15891
445	15891
490	20904
542	26613

NOTE: The terminal velocity of rain is approximately 2,000 feet per minute. Selections below this point are not recommended if rain entry into the building is a concern.

Models AMX, AMXR & AMXSH

Arr. 9, Horizontal

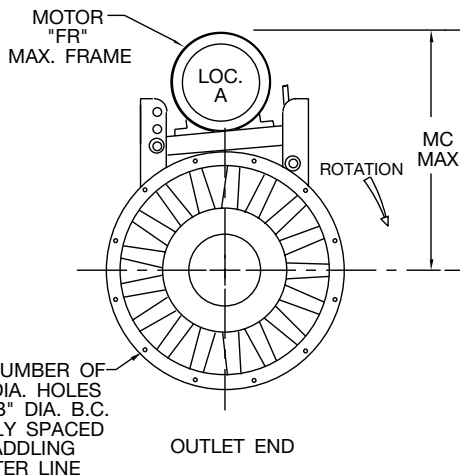
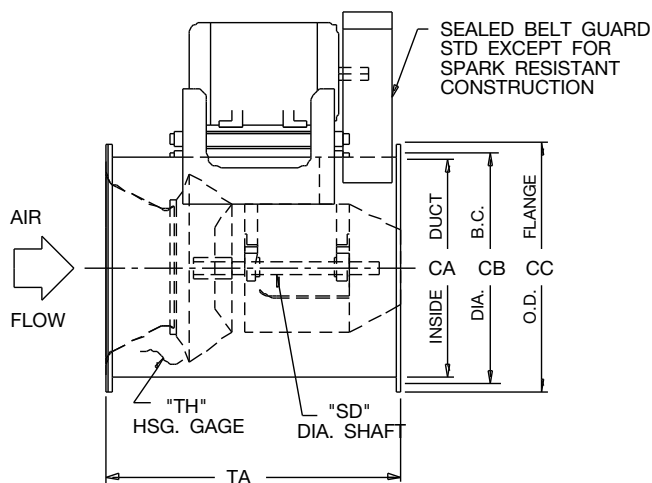

TYPE "AMX" HORIZONTAL DISCHARGE

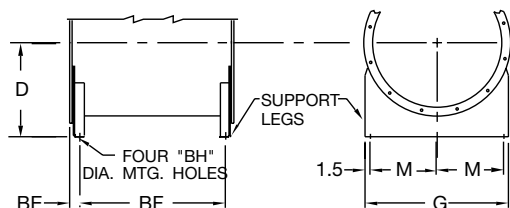

HBM HORIZONTAL BASE MOUNTED

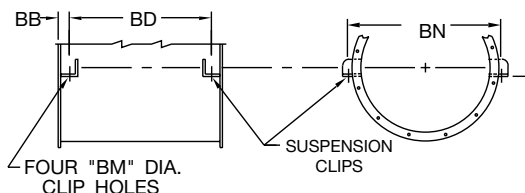

HCH HORIZONTAL CEILING HUNG

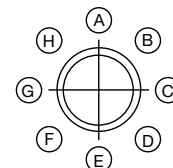

MOTOR LOCATION

VIEWED FROM OUTLET END

SIZE	BB	BD	BE	BF	BH	BM	BN	BT	CA	CB	CC	D	DH	FR	G	M	MC	NH	SD		TA	TH
																			CL I	CL II		
150	1.00	25.78	1.06	25.65	0.44	0.56	23.50	6.50	20.25	22.13	23.38	14.00	0.56	215T	23.38	10.19	25.73	8	1.000	1.187	27.78	10
165	1.00	28.63	1.06	28.50	0.44	0.56	25.88	6.50	22.25	24.38	25.75	15.00	0.69	256T	25.75	11.25	27.79	8	1.000	1.437	30.62	10
182	1.50	30.89	1.06	31.76	0.44	0.56	27.75	6.50	24.69	26.75	28.00	16.00	0.69	256T	28.00	12.50	34.45	12	1.000	1.437	33.89	12
200	1.50	34.18	1.06	35.05	0.56	0.56	30.13	7.25	27.06	29.13	30.31	18.00	0.81	256T	30.31	13.66	36.20	12	1.187	1.437	37.18	12
222	1.50	37.19	1.31	37.57	0.56	0.56	33.13	8.00	30.06	32.13	33.38	20.00	0.81	256T	33.38	15.19	37.65	12	1.187	1.437	40.19	12
245	1.50	41.31	1.31	41.69	0.56	0.81	36.25	8.93	33.13	35.13	36.38	21.00	0.81	286T	36.38	16.69	37.8	12	1.437	1.687	44.31	12
270	1.50	45.83	1.31	46.20	0.56	0.81	39.63	9.75	36.50	39.75	38.50	23.00	0.81	286T	39.75	18.38	42.16	12	1.437	1.687	48.83	12
300	1.50	51.52	1.31	51.89	0.56	0.81	43.75	10.93	40.56	43.13	44.88	25.00	0.81	326T	44.88	20.94	45.13	16	1.437	1.937	54.52	10
330	1.50	56.90	1.31	57.28	0.56	0.81	47.88	12.00	44.63	47.25	49.00	27.00	0.81	326T	49.00	23.00	46.56	16	1.687	2.187	59.90	10
365	2.00	62.37	1.56	63.25	0.81	0.81	52.56	13.25	49.38	52.00	53.75	29.00	0.81	365T	53.75	25.38	51.50	16	1.937	2.187	66.37	10
402	2.00	69.00	1.69	69.63	0.81	0.81	57.56	14.75	54.38	57.50	59.75	33.00	0.81	365T	59.75	28.38	59.77	16	1.937	2.187	73.00	10
445	2.00	76.92	1.69	77.54	0.81	0.81	63.38	16.25	60.19	63.25	65.50	36.00	0.81	405T	65.50	31.25	62.22	16	1.937	2.437	80.92	10
490	2.00	84.99	1.69	85.62	0.81	0.81	69.44	18.00	66.25	69.38	71.63	39.00	0.81	405T	71.63	34.31	67.68	24	2.187	2.437	88.99	10
542	2.00	94.71	2.44	93.84	0.81	1.06	76.56	19.88	73.38	77.00	79.75	43.00	0.81	445T	79.75	38.38	71.57	24	2.437	2.687	98.71	10
600	2.50	103.74	2.44	103.87	0.81	1.06	85.38	22.13	81.19	84.75	87.50	47.00	0.81	445T	87.50	42.25	78.47	24	2.687	2.937	108.74	10
660	2.50	115.11	2.44	115.24	1.06	1.06	93.56	24.25	89.31	92.88	95.63	52.00	0.81	445T	95.63	46.37	82.77	24	2.937	3.437	120.11	10
730	2.50	127.71	2.44	127.84	1.06	1.06	102.94	26.88	98.75	104.38	107.13	57.00	0.81	445T	107.13	52.06	87.75	24	2.937	3.937	132.77	10

AMX-R-1002527-A
AMXR-R-1002671
AMXSH-R-1002674

DIMENSIONS ARE SUBJECT TO CHANGE. CERTIFIED DRAWINGS AVAILABLE ON REQUEST.

Models AMX, AMXR & AMXSH Arr. 9, Vertical

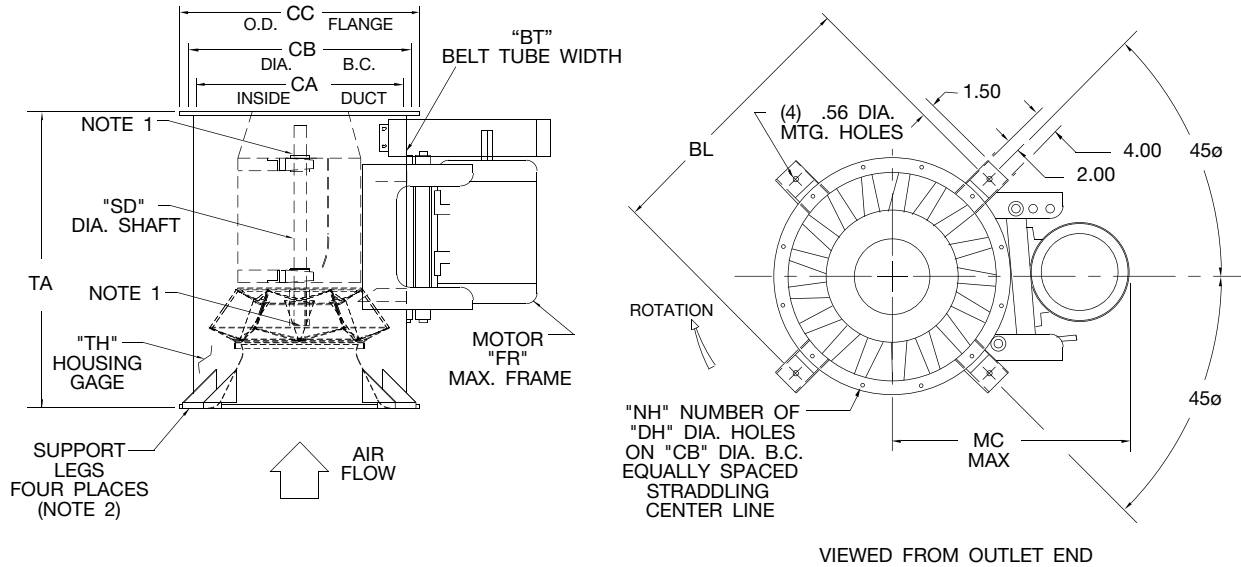

TYPE "AMX" VERTICAL UP DISCHARGE WITH FLOOR MOUNT SUPPORT LEGS

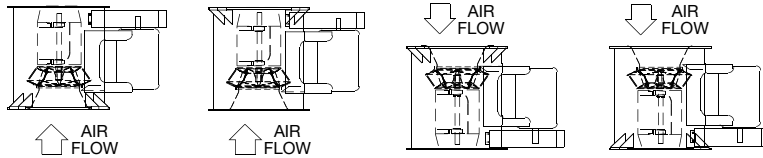

NOTES:

1. One locking collar and impeller hub cap included to prevent shifting of components.
2. Support legs shown are provided as an accessory.

VUI DISCHARGE UP FLOOR MOUNT
 VUO DISCHARGE UP CEILING HUNG
 VDI DISCH. DOWN CEILING HUNG
 VDO DISCH. DOWN FLOOR MOUNT

SIZE	BL	BT	CA	CB	CC	DH	FR	MC	NH	SD		TA	TH
										CLI	CLII		
150	25.38	6.50	20.25	22.13	23.38	0.56	215T	25.73	8	1.000	1.187	27.75	10
165	27.94	6.50	22.25	24.38	25.75	0.69	256T	27.73	8	1.000	1.437	30.36	10
182	33.00	6.50	24.69	26.75	28.00	0.69	256T	34.45	12	1.000	1.437	33.88	12
200	35.38	7.25	27.06	29.13	30.31	0.81	256T	36.20	12	1.187	1.437	37.19	12
222	38.00	8.00	30.06	32.13	33.38	0.81	256T	37.65	12	1.187	1.437	40.19	12
245	41.38	8.93	33.13	35.13	36.38	0.81	286T	37.86	12	1.437	1.687	44.31	12
270	44.75	9.75	36.50	38.50	39.75	0.81	286T	42.16	12	1.437	1.687	48.81	12
300	49.88	10.93	40.56	43.13	44.88	0.81	326T	45.13	16	1.437	1.937	54.56	10
330	54.00	12.00	44.63	47.25	49.00	0.81	326T	46.56	16	1.687	2.187	59.88	10
365	58.75	13.25	49.38	52.00	53.75	0.81	365T	51.50	16	1.937	2.187	66.38	10
402	64.75	14.75	54.38	57.50	59.75	0.81	365T	59.77	16	1.937	2.187	73.00	10
445	70.50	16.25	60.19	63.25	65.50	0.81	405T	62.22	16	1.937	2.437	80.94	10
490	76.63	18.00	66.25	69.38	71.63	0.81	405T	67.68	24	2.187	2.437	88.00	10
542	84.75	19.88	73.38	77.00	79.75	0.81	445T	71.51	24	2.437	2.687	98.69	10

AMX-R-1002528-C
 AMXR-R-1002672-C
 AMXSH-R-1002675-C

DIMENSIONS ARE SUBJECT TO CHANGE. CERTIFIED DRAWINGS AVAILABLE ON REQUEST.

Models AMX, AMXR & AMXSH Arr. 9, Vertical Roof

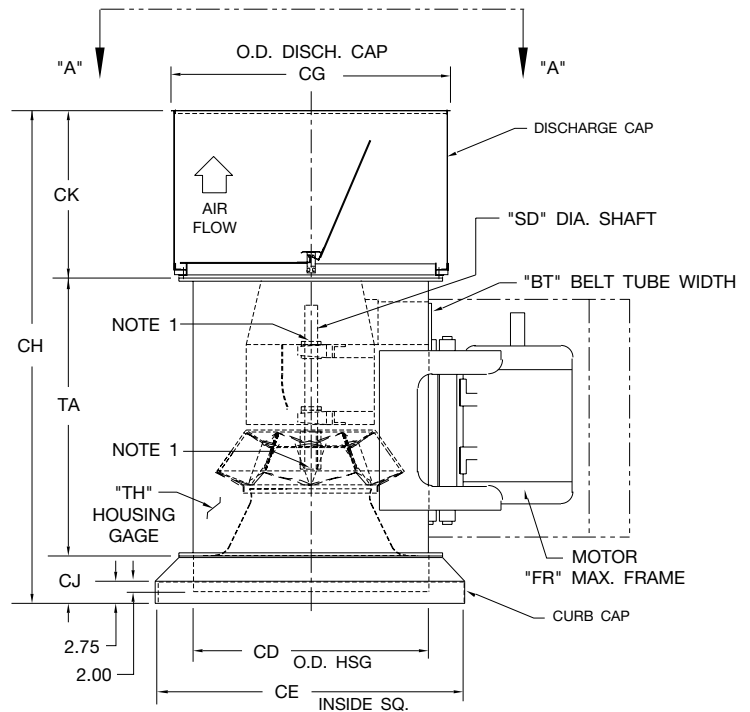
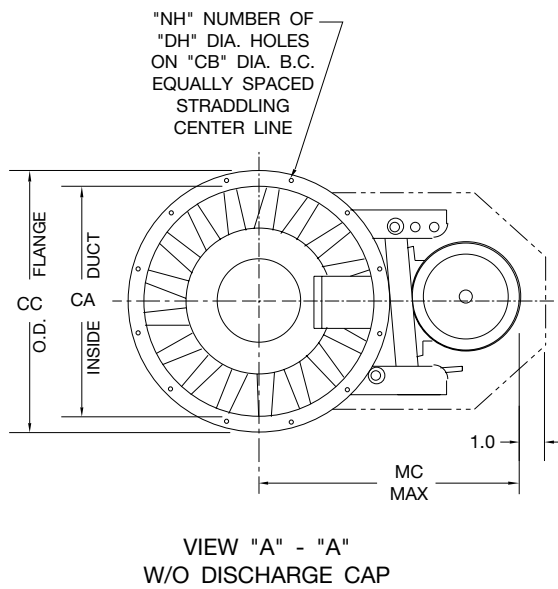

TYPE "AMX" VERTICAL DISCHARGE WITH DISCHARGE CAP AND CURB CAP

NOTES:

1. One locking collar and impeller hub cap included to prevent shifting of components.
2. Stack cap and curb cap are optional accessories.

SIZE	BL	BT	CA	CB	CC	CD	CE	CG	CH	CJ	CK	DH	FR	MC	NH	SD		TA	TH
																CLI	CLII		
150	25.38	6.50	20.25	22.13	23.38	20.50	27.38	30.00	48.75	6.00	15.00	0.56	215T	25.73	8	1.000	1.187	27.75	10
165	27.94	6.50	22.25	24.38	25.75	22.56	30.88	32.00	54.94	6.31	18.00	0.69	256T	27.73	8	1.000	1.437	30.36	10
182	33.00	6.50	24.69	26.75	28.00	24.88	34.88	34.00	58.50	6.63	18.00	0.69	256T	34.45	12	1.000	1.437	33.88	12
200	35.38	7.25	27.06	29.13	30.31	27.25	37.38	40.00	64.94	6.75	21.00	0.81	256T	36.20	12	1.187	1.437	37.19	12
222	38.00	8.00	30.06	32.13	33.38	30.25	40.38	40.00	67.94	6.75	21.00	0.81	256T	37.65	12	1.187	1.437	40.19	12
245	41.38	8.93	33.13	35.13	36.38	33.31	43.38	46.00	75.31	7.00	24.00	0.81	286T	37.86	12	1.437	1.687	44.31	12
270	44.75	9.75	36.50	38.50	39.75	36.69	46.75	46.00	80.06	7.25	24.00	0.81	286T	42.16	12	1.437	1.687	48.81	12
300	49.88	10.93	40.56	43.13	44.88	40.81	51.00	53.00	89.31	7.75	27.00	0.81	326T	45.13	16	1.437	1.937	54.56	10
330	54.00	12.00	44.63	47.25	49.00	44.88	55.13	59.00	97.63	7.75	30.00	0.81	326T	46.56	16	1.687	2.187	59.88	10
365	58.75	13.25	49.38	52.00	53.75	49.63	59.88	60.00	104.13	7.75	30.00	0.81	365T	51.50	16	1.937	2.187	66.38	10
402	64.75	14.75	54.38	57.50	59.75	54.63	64.88	67.00	114.00	8.00	33.00	0.81	365T	59.77	16	1.937	2.187	73.00	10
445	70.50	16.25	60.19	63.25	65.50	60.44	69.63	73.00	125.44	8.50	36.00	0.81	405T	62.22	16	1.937	2.437	80.94	10
490	76.63	18.00	66.25	69.38	71.63	66.50	78.00	80.00	138.00	9.00	40.00	0.81	405T	67.68	24	2.187	2.437	88.00	10
542	84.75	19.88	73.38	77.00	79.75	73.63	88.75	86.50	157.56	9.25	49.63	0.81	445T	71.51	24	2.437	2.687	98.69	10

AMX-R-1002529-B
AMXR-R-1002673-A
AMXSH-R-1002676-A

DIMENSIONS ARE SUBJECT TO CHANGE. CERTIFIED DRAWINGS AVAILABLE ON REQUEST.

Model AMX Arr. 4, Horizontal

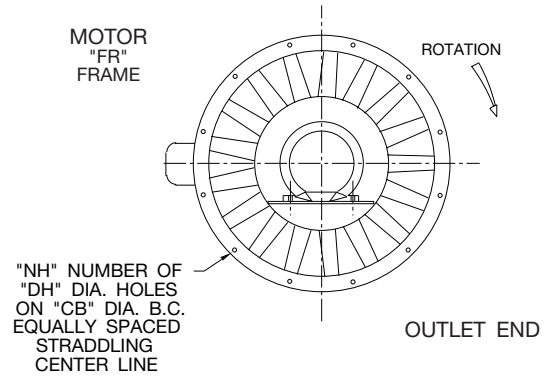
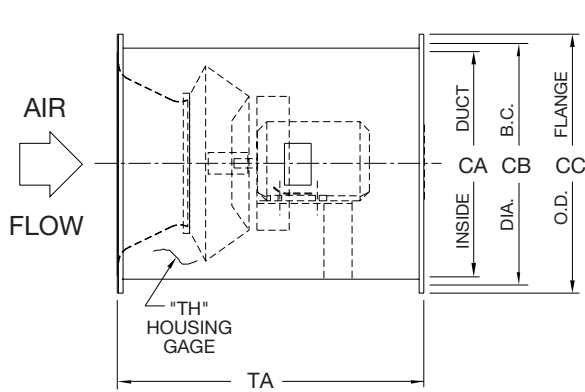

TYPE "AMX" HORIZONTAL DISCHARGE

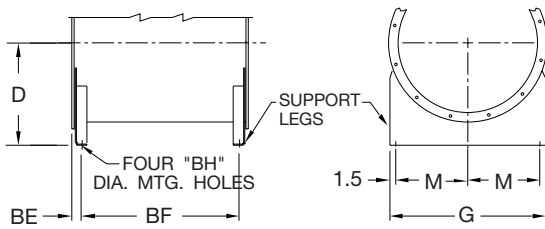

HBM HORIZONTAL BASE MOUNTED

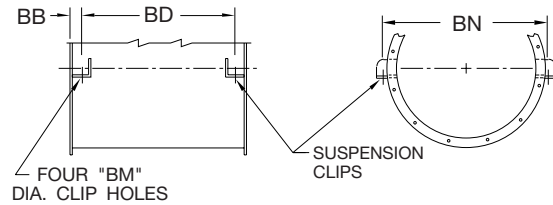

HCH HORIZONTAL CEILING HUNG

SIZE	BB	BD	BE	BF	BH	BM	BN	CA	CB	CC	D	DH	FR		G	M	NH	TA	TH
													MIN.	MAX.					
150	1.00	25.75	1.06	25.63	0.44	0.56	23.50	20.25	22.13	23.38	14.00	0.56	56	145T	23.38	10.19	8	27.75	10
165	1.00	28.63	1.06	28.50	0.44	0.56	25.88	22.25	24.38	25.75	15.00	0.69	56	184T	25.75	11.25	8	30.63	10
182	1.50	30.88	1.06	31.75	0.44	0.56	27.75	24.69	26.75	28.00	16.00	0.69	56	215T	28.00	12.50	12	33.88	12
200	1.50	34.19	1.06	35.06	0.56	0.56	30.13	27.06	29.13	30.31	18.00	0.81	56	254T	30.31	13.66	12	37.19	12
222	1.50	37.19	1.31	37.56	0.56	0.56	33.13	30.06	32.13	33.38	20.00	0.81	56	256T	33.38	15.19	12	40.19	12
245	1.50	41.31	1.31	41.69	0.56	0.81	36.25	33.13	35.13	36.38	21.00	0.81	56	286T	36.38	16.69	12	44.31	12
270	1.50	45.81	1.31	46.19	0.56	0.81	39.63	36.50	38.50	39.75	23.00	0.81	143T	286T	39.75	18.38	12	48.81	12
300	1.50	51.56	1.31	51.94	0.56	0.81	43.75	40.56	43.13	44.88	25.00	0.81	182T	326T	44.88	20.94	16	54.56	10
330	1.50	56.88	1.31	57.25	0.56	0.81	47.88	44.63	47.25	49.00	27.00	0.81	184T	326T	49.00	23.00	16	59.88	10
365	2.00	62.38	1.56	63.25	0.56	0.81	52.56	49.38	52.00	53.75	29.00	0.81	184T	405T	53.75	25.38	16	66.38	10
402	2.00	69.00	1.69	69.63	0.81	0.81	57.56	54.38	57.50	59.75	33.00	0.81	213T	405T	59.75	28.38	16	73.00	10
445	2.00	76.94	1.69	77.56	0.81	0.81	63.38	60.19	63.25	65.50	36.00	0.81	215T	445T	65.50	31.25	16	80.94	10
490	2.00	85.00	1.69	85.63	0.81	0.81	69.44	66.25	69.38	71.63	39.00	0.81	254T	445T	71.63	34.31	24	89.00	10
542	2.00	94.69	2.44	93.81	0.81	1.06	76.56	73.38	77.00	79.75	43.00	0.81	256T	445T	79.75	38.38	24	98.69	10
600	2.50	103.75	2.44	103.88	0.81	1.06	85.38	81.19	84.75	87.50	47.00	0.81	284T	445T	87.50	42.25	24	108.75	10
660	2.50	115.13	2.44	115.25	1.06	1.06	93.56	89.31	92.88	95.63	52.00	0.81	324T	445T	95.63	46.31	24	120.13	10
730	2.50	127.69	2.44	127.81	1.06	1.06	102.94	98.75	104.38	107.13	57.00	0.81	326T	445T	107.13	52.06	24	132.69	10

AMX-AC1002376A

DIMENSIONS ARE SUBJECT TO CHANGE. CERTIFIED DRAWINGS AVAILABLE ON REQUEST.

Model AMX Arr. 4, Vertical

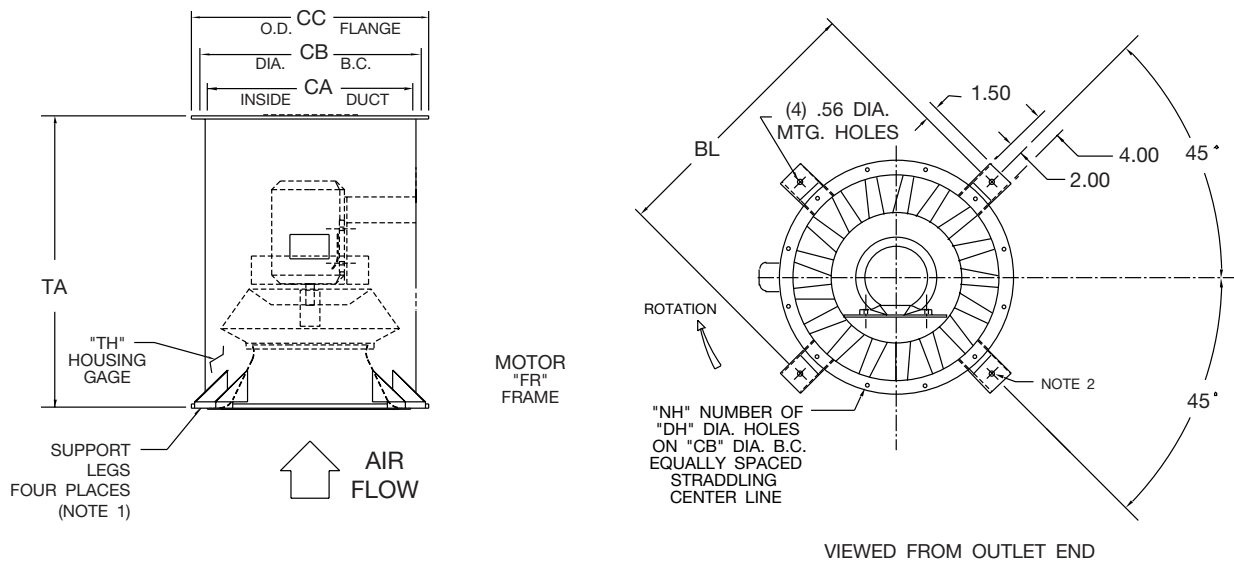

TYPE "AMX" VERTICAL UP DISCHARGE WITH FLOOR MOUNT SUPPORT LEGS (NOTE 1)

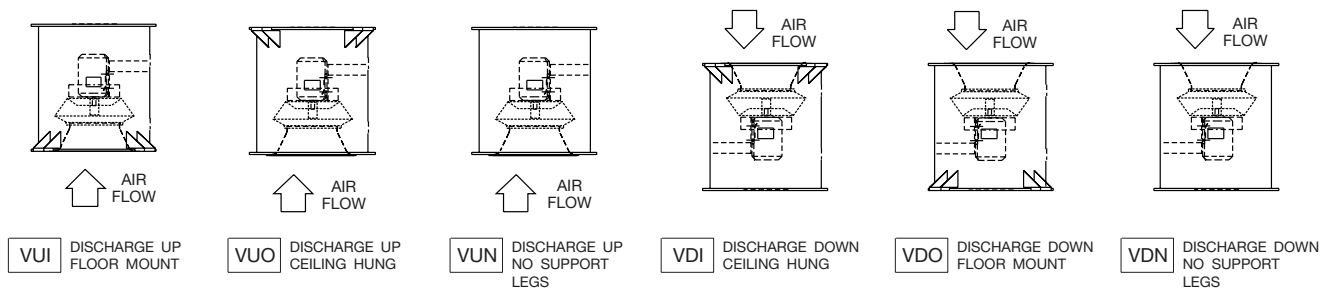

NOTE:

1. Support legs shown are provided as an accessory.

SIZE	BL	CA	CB	CC	DH	FR		NH	TA	TH
						MIN.	MAX.			
150	25.38	20.25	22.13	23.38	0.56	56	145T	8	27.75	10
165	27.94	22.25	24.38	25.75	0.69	56	184T	8	30.63	10
182	33.00	24.69	26.75	28.00	0.69	56	215T	12	33.88	12
200	35.38	27.06	29.13	30.31	0.81	56	254T	12	37.19	12
222	38.00	30.06	32.13	33.38	0.81	56	256T	12	40.19	12
245	41.38	33.13	35.13	36.38	0.81	56	286T	12	44.31	12
270	44.75	36.50	38.50	39.75	0.81	143T	286T	12	48.81	12
300	49.88	40.56	43.13	44.88	0.81	182T	326T	16	54.56	10
330	54.00	44.63	47.25	49.00	0.81	184T	326T	16	59.88	10
365	58.75	49.38	52.00	53.75	0.81	184T	405T	16	66.38	10
402	64.75	54.38	57.50	59.75	0.81	213T	405T	16	73.00	10
445	70.50	60.19	63.25	65.50	0.81	215T	445T	16	80.94	10
490	76.63	66.25	69.38	71.63	0.81	254T	445T	24	89.00	10
542	84.75	73.38	77.00	79.75	0.81	256T	445T	24	98.69	10

AMX-AC1002377B

DIMENSIONS ARE SUBJECT TO CHANGE. CERTIFIED DRAWINGS AVAILABLE ON REQUEST.



Model AMX

Fans shall be Model AMX (standard mixed flow) of the non-overloading design, as manufactured by Aerovent, Minneapolis, Minnesota.

PERFORMANCE — Performance ratings shall conform to AMCA Standard 208 (fan energy index), 211 (air performance) and 311 (sound performance). Fans shall be tested in accordance with ANSI/AMCA Standard 210 (air performance) and 300 (sound performance) in an AMCA accredited laboratory. Fans shall be licensed to bear the AMCA certified ratings seal for both sound and air and fan energy index (FEI). Sound certification shall apply to both inlet and outlet sound power levels.

Fans shall be designed for maximum efficiency. Fans shall have a sharply rising pressure characteristic extending through the operating range and continuing to rise well beyond the efficiency peak to assure quiet and stable operation under all conditions. Horsepower characteristics shall be truly self-limiting and shall reach a peak in the normal selection area.

Model AMX shall be available UL 705 listed. Fans shall bear a permanently attached nameplate displaying model and serial number of the unit for future identification.

HOUSING — Housings shall be cylindrical and welded steel throughout. Inlets shall be fully streamlined. Housings shall be suitably braced to prevent vibration or pulsation. Totally enclosed belt guard shall enclose motor sheave and V-belt drives. Punched inlet and outlet flanges shall be equipped for duct mounting. Extended lube lines shall be provided for ease of lubrication. Model AMX shall include bolted access door for inspection and maintenance of impeller.

IMPELLER — Fan impellers shall have die-formed hollow airfoil blades designed for maximum efficiency, and quiet and stable operation. Blades shall be continuously-welded to the back plate and impeller cone. Impellers shall be statically and dynamically balanced and the complete fan assembly including motor and drive shall be test balanced at or near the operating speed at the factory prior to shipment.

SHAFT (Arr. 9 Only) — Shafts shall be AISI 1040 or 1045 hot rolled steel, accurately turned, ground, polished and ring-gauged for accuracy. Shafts shall be sized for the first critical speed of at least 1.43 times the maximum speed.

BEARINGS (Arr. 9 Only) — Bearings shall be heavy-duty, grease lubricated, anti-friction ball or roller, self-aligning, pillow block type and selected for a minimum L-10 life of 40,000 hours at the maximum fan RPM. Bearings shall be equipped with extended lubrication lines with grease fittings outside of the fan housing.

DRIVE (Arr. 9 Only) — Motor sheaves shall be cast iron, variable pitch on applications 10 HP and smaller, and fixed pitch on 15 HP and larger.

FINISH AND COATING — The entire fan assembly, excluding the shaft, shall be properly washed and pretreated before application of a rust-preventative primer, if called out on the order. After the fan is completely assembled, a finish coat of paint shall be applied to the entire assembly, if called out on the order. The fan shaft shall be coated with a petroleum-based rust protectant. Aluminum components shall be unpainted.

FACTORY RUN TEST — All fans with motors and drives mounted by Aerovent shall be completely assembled and test run as a unit at the specified operating speed prior to shipment. Each impeller shall be statically and dynamically balanced in accordance with ANSI/AMCA 204-96 "Balance Quality and Vibration Levels for Fans" to Fan Application Category BV-3, Balance Quality Grade G6.3. Balance readings shall be taken by electronic type equipment in the axial, vertical and horizontal directions on each of the bearings. Records shall be maintained and a written copy shall be available upon request.

GUARANTEE — The manufacturer shall guarantee the workmanship and materials for its AMX Mixed Flow Fans for at least one (1) year from startup or eighteen (18) months from shipment, whichever occurs first.

Model

AMXR



Fans shall be Model AMXR (restaurant) of the non-overloading design, as manufactured by Aerovent, Minneapolis, Minnesota.

PERFORMANCE — Performance ratings shall conform to AMCA Standard 208 (fan energy index), 211 (air performance) and 311 (sound performance). Fans shall be tested in accordance with ANSI/AMCA Standard 210 (air performance) and 300 (sound performance) in an AMCA accredited laboratory. Fans shall be licensed to bear the AMCA certified ratings seal for both sound and air and fan energy index (FEI). Sound certification shall apply to both inlet and outlet sound power levels.

Fans shall be designed for maximum efficiency. Fans shall have a sharply rising pressure characteristic extending through the operating range and continuing to rise well beyond the efficiency peak to assure quiet and stable operation under all conditions. Horsepower characteristics shall be truly self-limiting and shall reach a peak in the normal selection area.

Model AMXR shall be UL 705 Supplement SC (formerly UL 762) listed for the exhaust of grease-laden air. Fans shall bear a permanently attached nameplate displaying model and serial number of the unit for future identification.

HOUSING — Housings shall be cylindrical and welded steel throughout. Inlets shall be fully streamlined. Housings shall be suitably braced to prevent vibration or pulsation. Totally enclosed belt guard shall enclose motor sheave and V-belt drives. Punched inlet and outlet flanges shall be equipped for duct mounting. Extended lube lines shall be provided for ease of lubrication. Model AMXR shall include a belt tube, 2 impeller cleanout doors (located 180° apart) for inspection and maintenance of the impeller and a 2" drain.

IMPELLER — Fan impellers shall have die-formed hollow airfoil blades designed for maximum efficiency, and quiet and stable operation. Blades shall be continuously-welded to the back plate and impeller cone. Impellers shall be statically and dynamically balanced and the complete fan assembly including motor and drive shall be test balanced at or near the operating speed at the factory prior to shipment. Impellers on model AMXR shall have cooling fins to draw cool air over shaft and bearings.

SHAFT — Shafts shall be AISI 1040 or 1045 hot rolled steel, accurately turned, ground, polished and ring-gauged for accuracy. Shafts shall be sized for the first critical speed of at least 1.43 times the maximum speed.

BEARINGS — Bearings shall be heavy-duty, grease lubricated, anti-friction ball or roller, self-aligning, pillow block type and selected for a minimum L-10 life of 40,000 hours at the maximum fan RPM. Bearings shall be equipped with extended lubrication lines with grease fittings outside of the fan housing.

DRIVE — Motor sheaves shall be cast iron, variable pitch on applications 10 HP and smaller, and fixed pitch on 15 HP and larger.

FINISH AND COATING — The entire fan assembly, excluding the shaft, shall be properly washed and pretreated before application of a rust-preventative primer, if called out on the order. After the fan is completely assembled, a finish coat of paint shall be applied to the entire assembly, if called out on the order. The fan shaft shall be coated with a petroleum-based rust protectant. Aluminum components shall be unpainted.

FACTORY RUN TEST — All fans with motors and drives mounted by Aerovent shall be completely assembled and test run as a unit at the specified operating speed prior to shipment. Each impeller shall be statically and dynamically balanced in accordance with ANSI/AMCA 204-96 "Balance Quality and Vibration Levels for Fans" to Fan Application Category BV-3, Balance Quality Grade G6.3. Balance readings shall be taken by electronic type equipment in the axial, vertical and horizontal directions on each of the bearings. Records shall be maintained and a written copy shall be available upon request.

GUARANTEE— The manufacturer shall guarantee the workmanship and materials for its AMXR Mixed Flow Fans for at least one (1) year from startup or eighteen (18) months from shipment, whichever occurs first.



Model AMXSH

Fans shall be Model AMXSH (smoke and heat) of the non-overloading design, as manufactured by Aerovent, Minneapolis, Minnesota.

PERFORMANCE — Performance ratings shall conform to AMCA Standard 208 (fan energy index), 211 (air performance) and 311 (sound performance). Fans shall be tested in accordance with ANSI/AMCA Standard 210 (air performance) and 300 (sound performance) in an AMCA accredited laboratory. Fans shall be licensed to bear the AMCA certified ratings seal for both sound and air and fan energy index (FEI). Sound certification shall apply to both inlet and outlet sound power levels.

Fans shall be designed for maximum efficiency. Fans shall have a sharply rising pressure characteristic extending through the operating range and continuing to rise well beyond the efficiency peak to assure quiet and stable operation under all conditions. Horsepower characteristics shall be truly self-limiting and shall reach a peak in the normal selection area.

Model AMXSH shall be UL listed for Smoke Control Systems (500°F for 4 hours and 1000°F for 15 minutes). Fans shall bear a permanently attached nameplate displaying model and serial number of the unit for future identification.

HOUSING — Housings shall be cylindrical and welded steel throughout. Inlets shall be fully streamlined. Housings shall be suitably braced to prevent vibration or pulsation. Totally enclosed belt guard shall enclose motor sheave and V-belt drives. Punched inlet and outlet flanges shall be equipped for duct mounting. Extended lube lines shall be provided for ease of lubrication. Model AMXSH shall include a belt tube for the protection of belts and drive components from the airstream and bolted access door.

IMPELLER — Fan impellers shall have die-formed hollow airfoil blades designed for maximum efficiency, and quiet and stable operation. Blades shall be continuously-welded to the back plate and impeller cone. Impellers shall be statically and dynamically balanced and the complete fan assembly including motor and drive shall be test balanced at or near the operating speed at the factory prior to shipment. Impellers on Model AMXSH shall have cooling fins to draw cool air over shaft and bearings.

SHAFT — Shafts shall be AISI 1040 or 1045 hot rolled steel, accurately turned, ground, polished and ring-gauged for accuracy. Shafts shall be sized for the first critical speed of at least 1.43 times the maximum speed.

BEARINGS — Bearings shall be heavy-duty, grease lubricated, anti-friction ball or roller, self-aligning, pillow block type and selected for a minimum L-10 life of 40,000 hours at the maximum fan RPM. Bearings shall be equipped with extended lubrication lines with grease fittings outside of the fan housing.

DRIVE — Motor sheaves shall be cast iron, variable pitch on applications 10 HP and smaller, and fixed pitch on 15 HP and larger. Model AMXSH shall be equipped with a two-groove drive minimum.

FINISH AND COATING — The entire fan assembly, excluding the shaft, shall be properly washed and pretreated before application of a rust-preventative primer, if called out on the order. After the fan is completely assembled, a finish coat of paint shall be applied to the entire assembly, if called out on the order. The fan shaft shall be coated with a petroleum-based rust protectant. Aluminum components shall be unpainted.

FACTORY RUN TEST — All fans with motors and drives mounted by Aerovent shall be completely assembled and test run as a unit at the specified operating speed prior to shipment. Each impeller shall be statically and dynamically balanced in accordance with ANSI/AMCA 204-96 "Balance Quality and Vibration Levels for Fans" to Fan Application Category BV-3, Balance Quality Grade G6.3. Balance readings shall be taken by electronic type equipment in the axial, vertical and horizontal directions on each of the bearings. Records shall be maintained and a written copy shall be available upon request.

GUARANTEE — The manufacturer shall guarantee the workmanship and materials for its AMXSH Mixed Flow Fans for at least one (1) year from startup or eighteen (18) months from shipment, whichever occurs first.



WALL MOUNTED FANS | TUBEAXIAL & VANEAXIAL FANS | CENTRIFUGAL FANS & BLOWERS
ROOF VENTILATORS | AIR HEATERS & COOLERS | AIR MAKE-UP | FIBERGLASS FANS | CUSTOM FANS

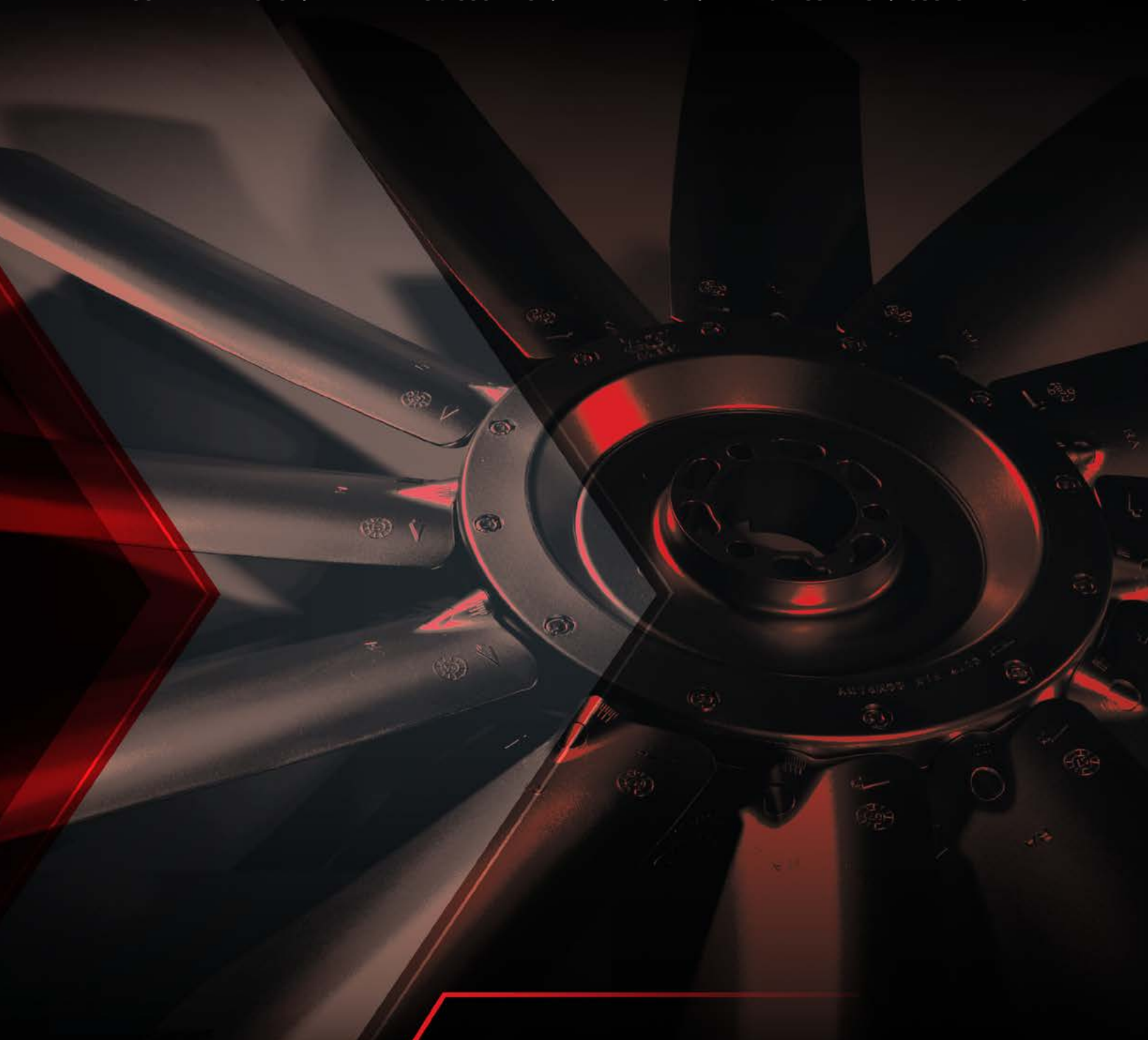

AEROVENT 
INDUSTRIAL VENTILATION SYSTEMS

AEROVENT.COM

5959 Trenton Lane N. | Minneapolis, MN 55442 | Phone: 763-551-7500 | Fax: 763-551-7501

©2006-2024 Aerovent, Minneapolis, MN. All rights reserved. Catalog illustrations cover the general appearance of Aerovent products at the time of publication and we reserve the right to make changes in design and construction at any time without notice.