



Electronic commutation (EC) is the latest motor technology to be used in direct drive fans. Also known in the industry as Brush Free or Brushless DC, the EC motors utilize an electronic circuit board to control the functionality of the motor. The motor operates off of 115V or 208/230V AC single-phase power or 208/230V or 460 three-phase power, which is converted to DC power within the motor's circuitry. The result is a highly efficient motor with an expanded speed control range and a variety of speed control options from which to choose.



*Model PCU  
with EC motor*



### REVIEW AMCA BULLETIN 410 AND PRODUCT I&M PRIOR TO INSTALLATION

This manual has been prepared to guide the users of electronically commutated motors in the proper installation, operation and maintenance procedures to ensure maximum equipment life with trouble-free operation. For safe installation, startup and operational life of this equipment, it is important that all involved with the equipment be well versed in proper fan safety practices and read this manual. It is the user's responsibility to make sure that all requirements of good safety practices and any applicable safety codes are strictly adhered to. Because of the wide variety of equipment covered in this manual, the instructions given here are general in nature. Additional product and engineering information is available at [www.aerovent.com](http://www.aerovent.com).

### SAFETY NOTICE

Refer to the safety section(s) in the product installation and maintenance manuals prior to installing or servicing the EC motor. The most current version of this installation and maintenance manual can be found on our website at [www.aerovent.com/resources/im-manuals](http://www.aerovent.com/resources/im-manuals).

### TABLE OF CONTENTS

Electrical Connection .....	2
Speed Control Options: ODP & TENV Motors .....	2-7
Speed Control Options: TEFC Motors .....	8-9
Speed Control Options: OP Motors .....	10
Maintenance .....	11
Troubleshooting .....	11

**ELECTRICAL CONNECTION**

1. Connect supply wiring to the disconnect switch (non-fused standard).
2. The motor is factory set at the voltage marked on the fan nameplate. Check the line voltage with the nameplate voltage.
3. The main power wiring should be sized for the ampacity shown on the nameplate. Size wires in accordance with the ampacity tables in Article 310 of the National Electrical Code. If long wires are required, it may be necessary to increase wire size to prevent excessive voltage drop. Wires should be sized for a maximum of 3% voltage drop.
4. Disconnect switches are not fused. The power leads must be protected at the point of distribution in accordance with the fan nameplate.
5. All units must be electrically grounded in accordance with local codes or, in the absence of local codes, with the latest edition of the National Electrical Code (ANSI/NFPA 70). A ground lug is provided as standard in the unit terminal box. Size grounding conductor in accordance with Table 250-95 of the National Electrical Code. DO NOT use the ground lug for connecting a neutral conductor.
6. Supply voltage to the power ventilator should not vary by more than 10% of the value indicated on the unit nameplate. Phase unbalance must not exceed 2%.

**CAUTION**

1. Use copper conductors only.
2. Protect wiring from sharp edges. Leave some slack in the line to prevent damage. Do not allow the power or speed control cables to kink or come in contact with oil, grease, hot surfaces or chemicals. If damaged, discontinue use immediately and have cord replaced. Use proper strain relief.

**SPEED CONTROL OPTIONS: ODP & TENV MOTORS**

The following speed control options are available for the Aerovent EC motor. Coming standard with the motor is both a motor mounted dial, for speed adjustment at the fan and a 0-10V DC control lead. The 0-10V DC control lead can be used with a remote speed control, either field supplied or supplied by Aerovent. See table to the right for available control methods and applicable sections. See Maximum RPM tables on page 7 for maximum allowable RPM for fan/motor combinations.

HP	Voltage	Encl.	RPM Range	Control Method	Motor Part Nmbrs.	Options	Page
1/8	115/230	ODP	200-1800	GridPoint/0-10V/RMD	500027447	2,3,4	2-4
1/6	115	ODP	300-1800	MMD/0-10V/RMD	67001008	1,2,4	2-4
	115/230	ODP	200-1800	GridPoint/0-10V/RMD	500027446	2,3,4	2-4
1/4	115	ODP	300-1800	MMD/0-10V/RMD	67001001	1,2,4	2-4
1/4	208-230	TENV	300-1800	MMD/0-10V/RMD	67002101	1,2,4	2-4
1/4	115/230	ODP	200-1800	GridPoint/0-10V/RMD	67001701	2,3,4	2-4
1/2	115	ODP	300-1800	MMD/0-10V/RMD	67001003	1,2,4	2-4
1/2	208-230	ODP	350-1800	MMD/0-10V/RMD	67001103	1,2,4	2-4
1/2	115/230	ODP	200-1800	GridPoint/0-10V/RMD	67001703	2,3,4	2-4
3/4	115	ODP	300-1800	MMD/0-10V/RMD	67001004	1,2,4	2-4
3/4	208-230	ODP	350-1800	MMD/0-10V/RMD	67001104	1,2,4	2-4
3/4	115/230	ODP	200-1800	GridPoint/0-10V/RMD	67001704	2,3,4	2-4
1	115	ODP	300-1800	MMD/0-10V/RMD	67001005	1,2,4	2-4
1	208-230	ODP	350-1800	MMD/0-10V/RMD	67001015	1,2,4	2-4
1	115/230	ODP	200-1800	GridPoint/0-10V/RMD	67001705	2,3,4	2-4
1	115	ODP	350-1200	MMD/0-10V/RMD	67001105	1,2,4	2-4
1	208-230	ODP	350-1200	MMD/0-10V/RMD	67001115	1,2,4	2-4
1	115	TEFC	200-1800	MMD/0-10V	67002205	Fig. 6, 7	8-9
2	208-230	TEFC	200-1800	MMD/0-10V	67002107	Fig. 6, 7	8-9
1	460	OPEN	300-1800	0-10V	67003405	Fig. 9	10
1-1/2	460	OPEN	300-1800	0-10V	67003406	Fig. 9	10
2	460	OPEN	300-1800	0-10V	67003407	Fig. 9	10
3	460	OPEN	300-1800	0-10V	67003409	Fig. 9	10



**1. Motor Mounted Dial, MMD (Standard Feature)**  
 – A potentiometer is mounted to the motor housing offering full speed control range. Speed adjustment is made with a small flat head screwdriver. With this option, the motor's 0-10V DC control leads are terminated in a standard 2x4 junction box from the factory and can remain there if not required by the end user.



**2. 0-10V DC Lead (Standard Feature)** – A 36" long control lead is prewired from the motor, which accepts a 0-10V DC signal and can be wired into building control systems or field supplied controls. With this option, the control leads are terminated in a standard 2x4 junction box from the factory.

**CAUTION**

Always disconnect power before inspection or maintenance. Although motor may be off and not running when a 0-1.9V DC signal is present, high voltage will still be present at the motor.

**SPEED CONTROL OPTIONS: ODP & TENV MOTORS (CONT.)**

Field supplied controllers should be provided and installed by others and send the motor a 0-10V DC signal. A 24V AC or DC source is also required to power the controls in the motor. Note that the motor mounted dial or the GridPoint Controller acts as a speed reference for this option. In order to have the full speed control range available for a given fan/motor combination, the motor mounted dial must be turned all the way in the CW direction or to the maximum RPM allowable for the fan/motor combination (see Max RPM tables on page 7). The motor operates off of a 2-10V DC signal while the motor will be off when a 0-1.9V DC signal is present. See table below for speed reference charts. **It is the responsibility of the installer/controls engineer to ensure that any field supplied controls are compatible and functional with this motor technology. Aerovent is not responsible for field supplied or customer designed fan or motor controls.**

DC Input	Description	Motor Part Numbers
0 – 1.9V	Motor is Off	67001701, 67001703,
2.0V	Motor is On, at 200 RPM	67001704, 67001705,
2.0V – 8.5V	Motor is On, speed linear between 200 RPM and maximum speed (set by GridPoint Controller)	67001715, 500027446,
8.5V – 10V	Motor is On, at maximum speed	500027447

DC Input	Description	Motor Part Numbers
0 – 1.9V	Motor is Off	67001001, 67001003,
2.0V	Motor is On, at low RPM	67001004, 67001005,
2.0V – 8.5V	Motor is On, speed linear between low and maximum speed	67001008, 67001015,
8.5V – 10V	Motor is On, at maximum speed	67001103, 67001104,
		67001105, 67001115,
		67002101

3. **GridPoint Controller** – The motor will be factory set and labeled at the RPM specified by the customer. A 36" long control lead with a three-pin connector is prewired from the motor. The three-pin connector attaches to the GridPoint Controller, a hand held device that can set the motor to a specific RPM.  
*Note: More than one fan can be controlled by a single GridPoint Controller.*



**Instructions**

1. Fan must be running when the controller is used.
2. Turn the controller on and plug it into the motor. It will automatically connect.
3. The display will show the current speed. Power, Connect and Direction LEDs will be on.
4. If the Up arrow is pressed, the display will show E000 (no error), max speed, constant speed, d000 (direction) and C000 (motor operation mode 0).
5. To set the maximum speed:
  - a. Press 'SET' for 2s.
  - b. Press the Up or Down arrow to display P000.
  - c. Press 'OK'. This will display the current maximum speed.
  - d. Press the Up or Down arrow to change the digit. To move to the next digit, press and hold the Up arrow until the next digit flashes. Keep changing values until the desired speed is reached.
  - e. Press 'OK' to save the value. Press 'OK' again to go back to the first display.
  - f. Press 'O' for 2s to send the command to the motor.
6. To set the speed for Constant speed operation:
  - a. Press 'SET' for 2s.
  - b. Press Up or Down arrow to select P001.
  - c. Press 'OK'. The default value is '0'. Change to desired speed by following steps 5d and 5e.
  - d. Press 'M' for 2s to send the command to the motor.
7. To set motor operation mode:
  - a. Press 'SET' for 2s.
  - b. Press the Up or Down arrow to display P008.
  - c. Press 'OK'.
  - d. Arrow Up or Down to select desired mode. (See Parameters section above for functionality.)
  - e. Press 'OK' to save the value.
  - f. Press 'M' for 2s to send the command to the motor.
8. Once programming is complete, move to the next fan or store the GridPoint Controller in a safe location for future adjustments.

**SPEED CONTROL OPTIONS: ODP & TENV MOTORS (CONT.)**

4. **Remote Mounted Dial, RMD (Optional Feature)** – A wall mounted dial allows the fan to be controlled from within the building by sending the motor a 0-10V DC option. This option includes a 115V or 230V (depending upon the motor voltage selected) to 24V AC transformer mounted in the NEMA electrical enclosure. On models PC, PCU, ACXD, ATD/R and ATDW/R the junction box for the transformer will be located within the fan motor enclosure/weather cover. On model SCDD, the junction box for the transformer will be located on the exterior of the fan.



With this option a three-wire control cable must be field supplied and wired from the 24V AC transformer box to the remote location of the controller. In addition, a standard 2x4 single gang electrical junction box (by others) is required to mount the controller. The maximum distance from the remote mounted controller to the motor is 100 feet. Distances greater than this could cause a loss of the signal to the motor and result in unstable motor performance.

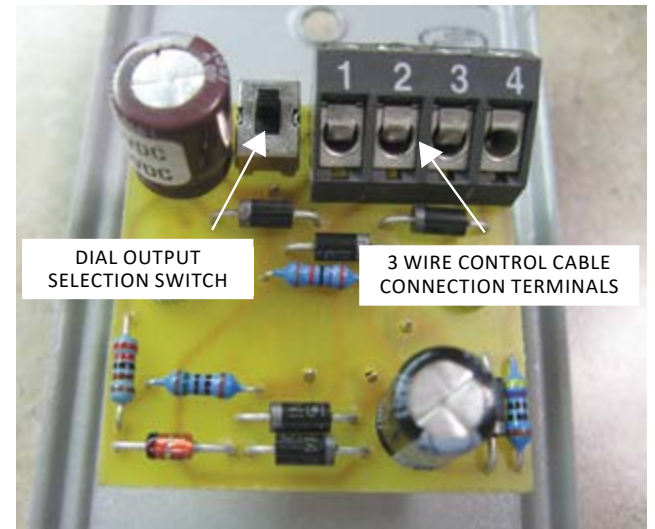

**CAUTION**

Always disconnect power before inspection or maintenance. Although motor may be off and not running when a 0-1.9V DC signal is present, high voltage will still be present at the motor.

**Note:** This section refers to motors 67001001, 67001003, 67001004, 67001005, 67001008, 67001015, 67001103, 67001104, 67001105, 6700115, 67001701, 67001703, 67001704, 67001705, 67001715, 67002101, 67002107, 67002205, 500027446, 500027447.



On the back of the remote mounted dial there is a small switch that will allow the user to change the output of the remote mounted dial. The settings of the switch are 0-10V or 2-10V. A label on the rear of the controller's printed circuit board describes the settings. The motor will run regardless of which setting the dial is at, but because the motor operates off of a 2-10V DC signal, it will be off when a 0-1.9V DC signal is present. If the user requires the remote mounted dial to turn off the motor, the dial should be set at 0-10V DC.

The field supplied three-wire control cable connections from the transformer box to the remote mounted dial must be made as shown in table to the right:

Connection in Transformer Box	Description	Terminal on Back of Dial
Yellow/White	Common	1
Blue/Black	24V AC	2
Red	0-10V DC	3

The user should verify that the dial is properly working by adjusting the dial and checking that the motor speed changes accordingly. The voltage at the dial should also be verified. 24V AC should be present across terminal 1 and 2. Terminals 1 and 3 should have a DC voltage in the range of 0-10V DC, which should vary as the dial is adjusted.

Note that the motor mounted dial acts as a speed reference for this option. In order to have the full speed control range available for a given fan/motor combination, the motor mounted dial must be turned all the way in the CW direction or to the maximum RPM available.

Refer to motor part numbers in Figures 1, 2 and 3 for detailed wiring diagrams for the Remote Mounted Dial option.

Figure 1. Remote Mounted Dial Wiring Diagram — 115VAC Single-Phase

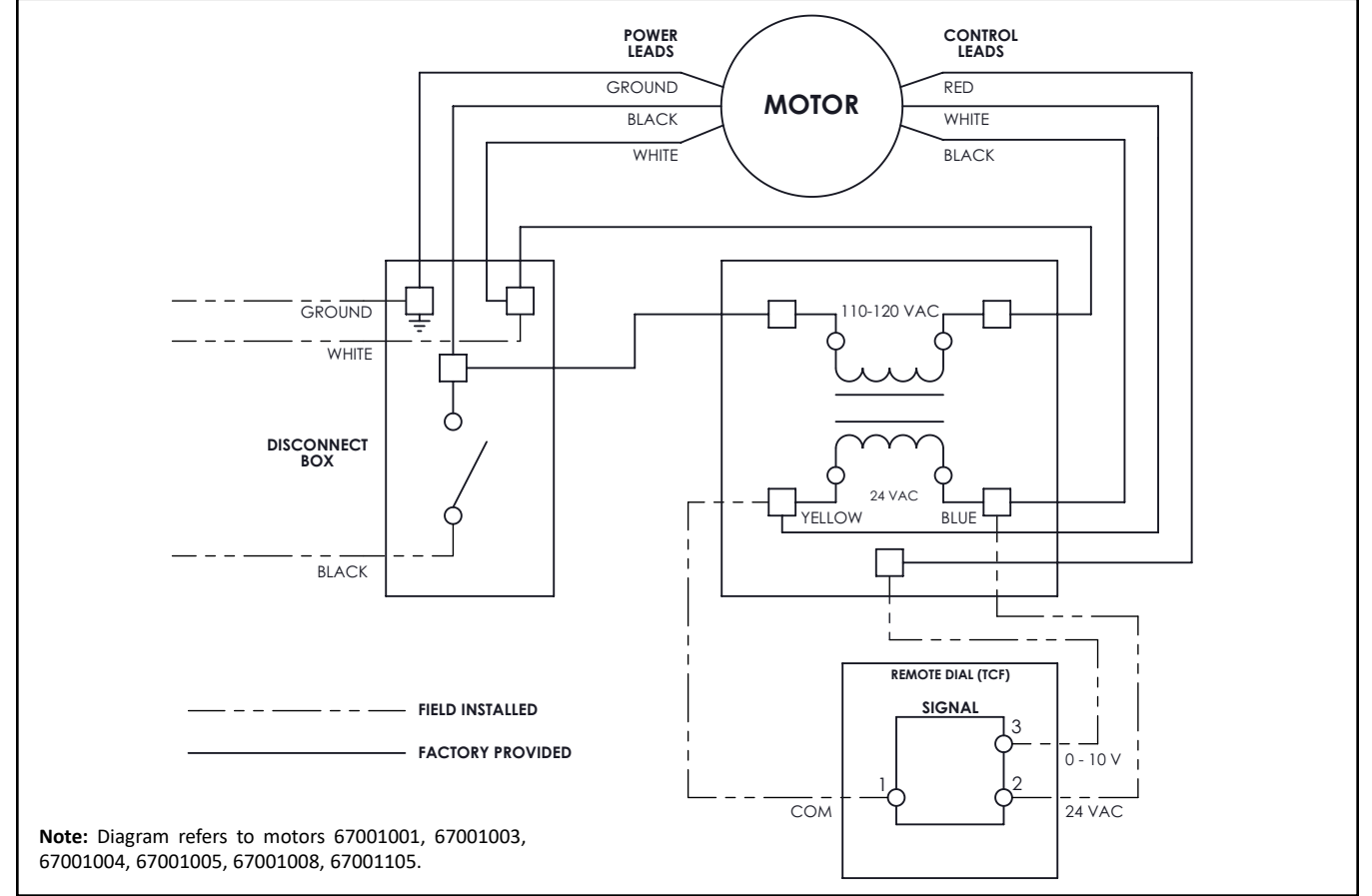

Figure 2. Remote Mounted Dial Wiring Diagram — 208-230VAC Single-Phase

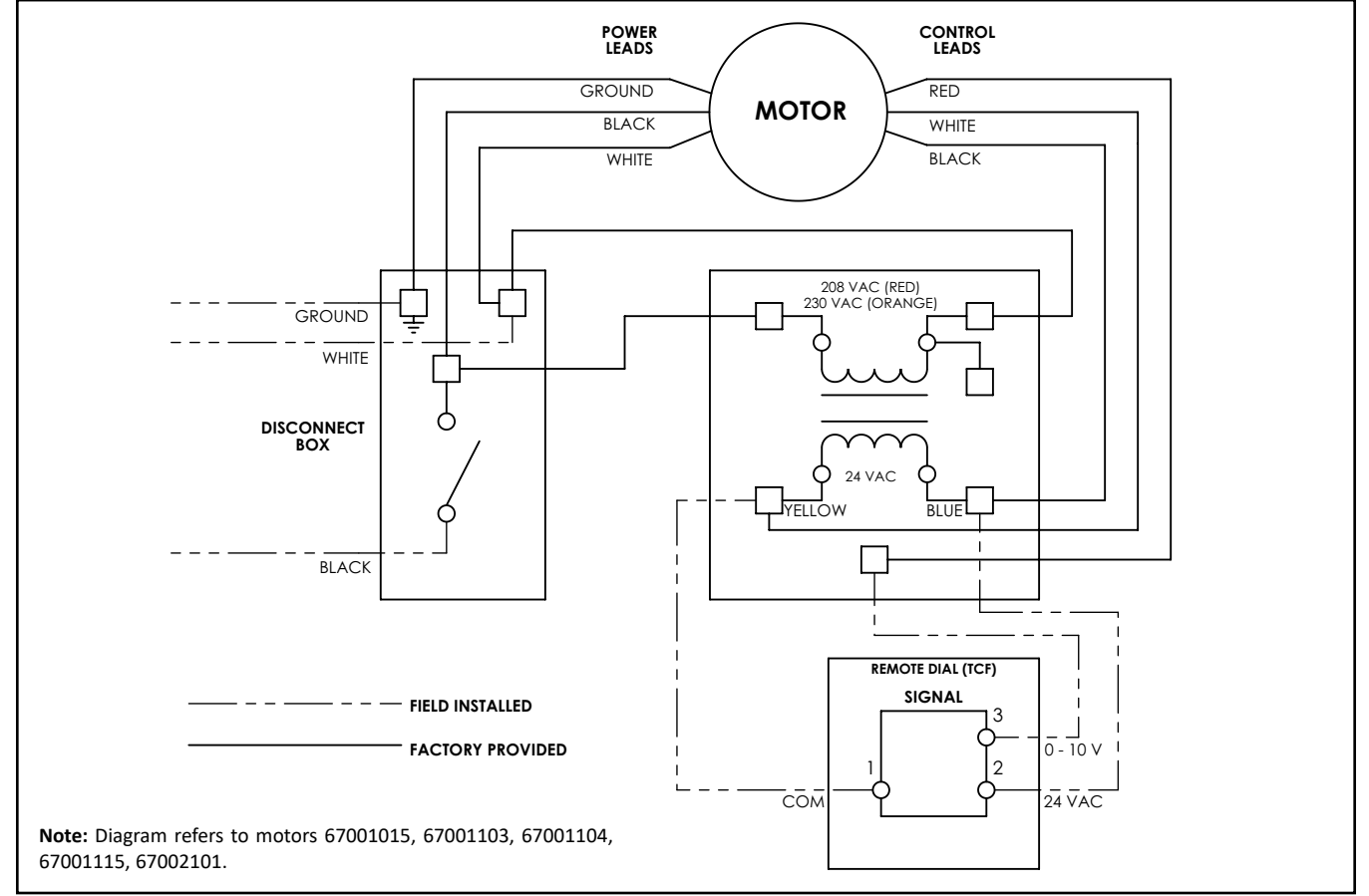
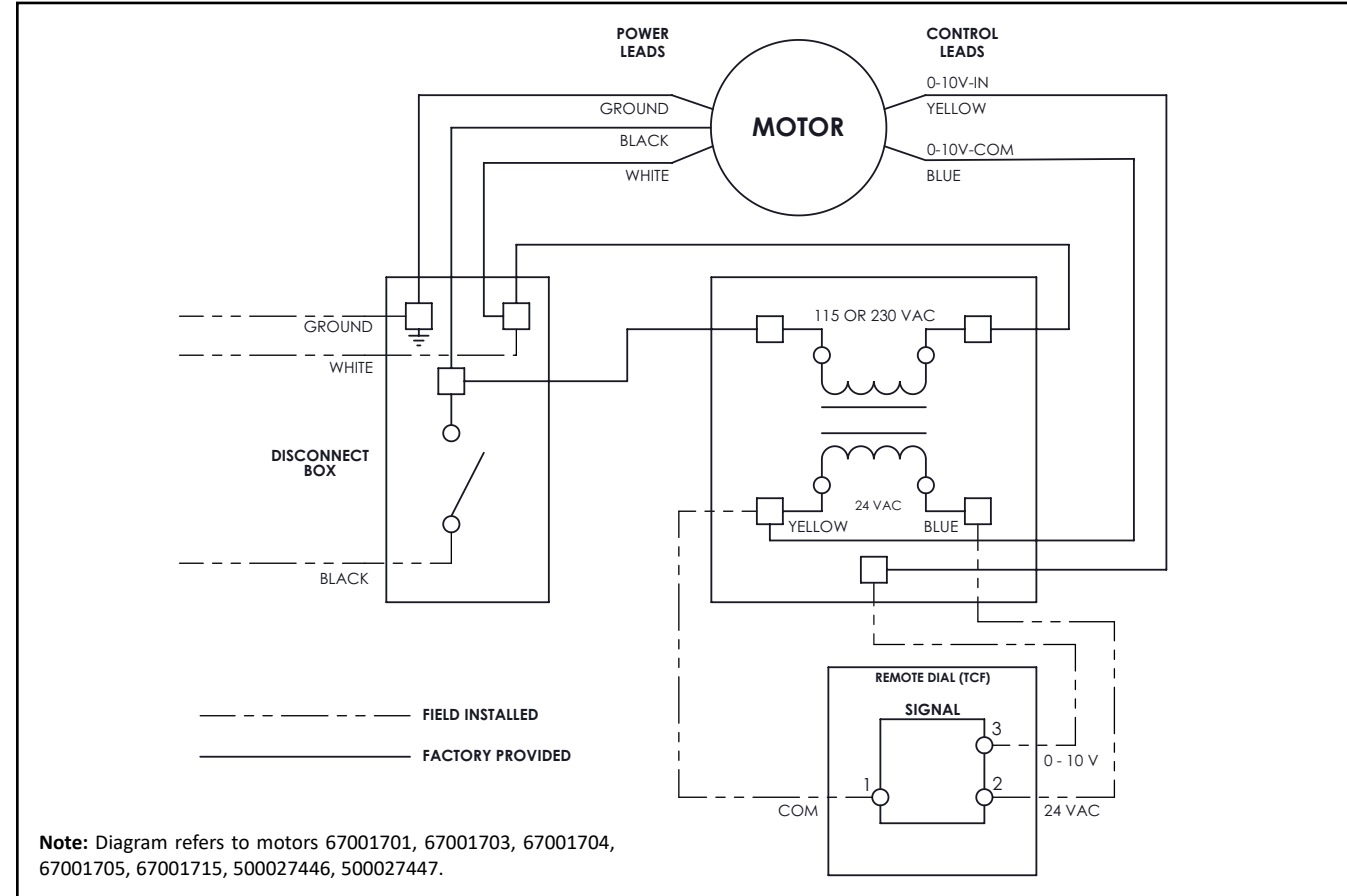

Figure 3. Remote Mounted Dial Wiring Diagram — 115 or 230VAC Single-Phase



Maximum RPM Tables

SCDD			
Size	Motor HP	Motor RPM	Max Fan RPM
080AE	1/4	1800	1800
090AE	1/4	1800	1800
100AE	1/2	1800	1800
120AE	3/4	1800	1800
135AE	1	1800	1800
150AE	1	1200	1200
165AE	1	1200	1200
135ANE	3/4	1800	1800
150ANE	1	1800	1800
165ANE	1	1200	1200

ATD			
Size	Motor HP	Motor RPM	Max Fan RPM
073BE	1/4	1800	1800
083BE	1/4	1800	1800
093BE	1/4	1800	1800
110BE	1/2	1800	1800
120BE	3/4	1800	1800
140BE	1	1800	1800
160BE	1	1200	1200
180BE	1	1200	1200

ACXD			
Size	Motor HP	Motor RPM	Max Fan RPM
060BE	1/4	1800	1800
070BE	1/4	1800	1800
080BE	1/4	1800	1800
085BE	1/4	1800	1800
090BE	1/4	1800	1800
095BE	1/4	1800	1800
100BE	1/4	1800	1800
120BE	1/2	1800	1800
130BE	3/4	1800	1800
140BE	3/4	1800	1800
150BE	1	1800	1400
150BE	1	1200	1200
160BE	1	1200	1200
170BE	1	1200	1200
180BE	1	1200	1200

PC			
Size	Motor HP	Motor RPM	Max Fan RPM
077	1/4	1800	1800
083	1/4	1800	1800
085	1/8	1800	1800
	1/6	1800	1800
089	1/4	1800	1800
	1/8	1800	1800
089	1/6	1800	1800
	1/2	1800	1800
098	1/8	1800	1800
	1/6	1800	1800
112	1/2	1800	1800
	1/2	1800	1800

PCU			
Size	Motor HP	Motor RPM	Max Fan RPM
085	1/8	1800	1800
	1/6	1800	1800
089	1/4	1800	1800
	1/8	1800	1800
098	1/6	1800	1800
	1/4	1800	1800
110	1/4	1800	1800
112	1/4	1800	1800
122	1/2	1800	2205
124	1/2	1800	1800
135	3/4	1800	1800
140	3/4	1800	1800
150	1	1800	1800
157	1	1800	1800
165	1	1800	1800
177	1	1200	1800
182	1	1200	1800
197	1	1200	1800

### SPEED CONTROL OPTIONS: TEFC MOTORS

This section covers the motors listed in the chart on the right.

#### Installation

1. Connect the motor to AC power and ground the external speed control. Follow Figures 4 and 5 below for appropriate voltage. Use appropriate strain relief (not provided) and branch protection.

Motor Part Numbers	HP	Voltage/Phase
67002205	1	115/208-230/1
67002107	2	208-230/1

**CAUTION**

Do not remove conduit box cover for at least five (5) minutes after AC power is disconnected to allow capacitors to discharge. Dangerous voltages are present inside the equipment even when the motor is not rotating. Electrical shock can cause serious or fatal injury.

#### AC power

Connect it to the motor control as follows:

- a. Connect 115VAC (Black) to L1.
- b. Connect Neutral (White) to N.
- c. Connect Ground to Ⓢ.

Use only Copper Wire for all wiring, minimum 75°C.

**CAUTION**

Connection of 115VAC power to "N" will damage the unit.

Figure 4. 115VAC Power Connection to Motor Speed Controller

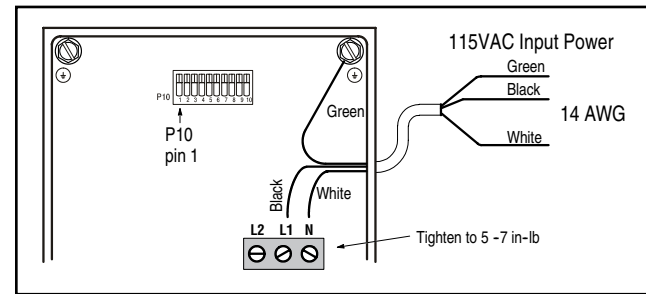

#### AC power

Connect it to the motor control as follows:

- a. Connect 230V (White) to L1.
- b. Connect 230V (Black) to L2.
- c. Connect Ground to Ⓢ.

Use only Copper Wire for all wiring, minimum 75°C.

**CAUTION**

Connection of 230VAC power to "N" will damage the unit.

Figure 5. 230VAC Power Connection to Motor Speed Controller

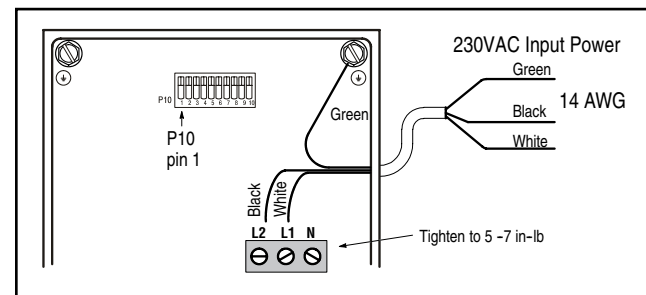

Table 1. Single-Phase Power Requirements

Nominal AC Voltage	Minimum AC Volts	Maximum AC Volts	HP	Input A <sub>RMS</sub>	Output A <sub>RMS</sub>
115	103	126	1.0	12.0	2.83
			1.0	6.0	2.83
230	200	264	2.0	12.0	5.29

**Note:** Internally, the Speed Controller provides 240VAC 3 phase at 8kHz switching frequency to the motor.

Table 2. Branch Protection

Motor Assembly	Fuses				Maximum UL Listed Circuit Breaker
	Fast-Acting		Time-Delay		
	Class	Max Rating	Class	Max Rating	
All (1HP-2HP)	RK1	20A	RK5	20A	20A

**Note:** A different fuse Class may be used as an alternative to the Class shown, provided it is of the same or lesser rating and has equivalent (or better) clearing time and peak let-through characteristics (i.e. Class H, K1, J, T, etc.)

### SPEED CONTROL OPTIONS: TEFC MOTORS (CONT.)

2. Connect the motor to the appropriate speed control option. The motor can accommodate 1 of 2 methods for speed control. The first method is a potentiometer (also known as a remote speed control or motor mounted dial). This is an analog dial that controls the speed of the motor by sending a variable 0-10V DC signal to the motor. CW rotation of the potentiometer increases the speed and CCW rotation decreases the speed (all the way CCW turns the motor off). Note that the motor will run between 2-10V and will shut off from 0-1.9V. See Figure 6 below for details on wiring a potentiometer if required.

Connect the Speed Control Potentiometer to the motor control as follows:

- a. Connect one end of Potentiometer to P10-1 (12V DC).
- b. Connect center (wiper) of Potentiometer to P10-2 (Analog Input)
- c. Connect other end of Potentiometer to P10-3 (DGND)

Use only Copper Wire for all wiring.



Figure 6. Motor Speed Controlled by a Remote Speed Control Dial (Potentiometer)

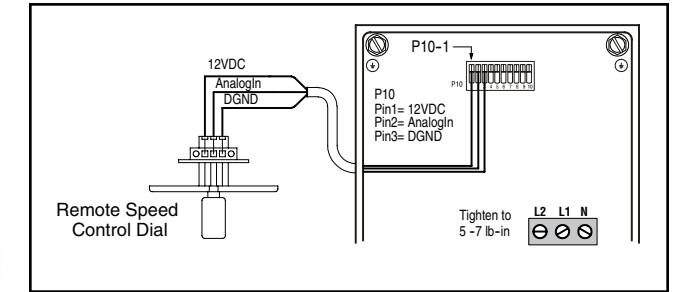

The second speed control method is to send the motor a 0-10V DC control signal. From the factory, a two-wire harness is provided for field connections. Note that the motor does not require a 24V power source to operate in this mode. See Figure 7.

Connect the Control Signal Harness to the motor control as follows:

- a. Connect a positive voltage source to pin P10-2 (Analog Input)
- b. Connect source common to P10-3 (DGND)

Use only Copper Wire for all wiring.

Description	Wire Color
0-10V DC (Analog Input)	Red
Ground (DGND)	White



Figure 7. Motor Speed Controlled by 0-10V DC Control Signal

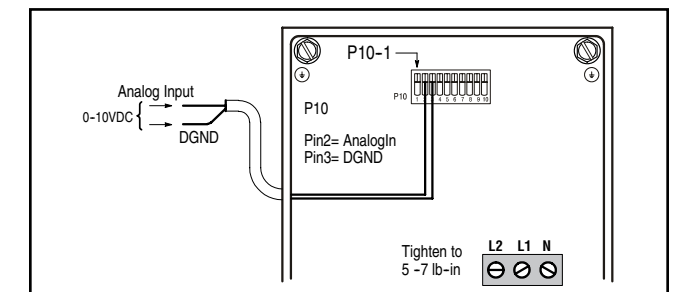

**It is the responsibility of the installer/controls engineer to ensure that any field supplied controls are compatible and functional with this motor technology. Aerovent is not responsible for field supplied or customer designed fan or motor controls.**

3. Verify rotation of motor is correct by energizing the motor and checking that the rotation matches the fan rotation label. This can also be done before any speed controls are wired in by placing a jumper wire between terminals Pin 1 and Pin 2. This will send 10 volts into the motor and cause it to run at full speed. To change the rotation of the motor, swap the T1 (Black) and T2 (Blue) leads (as shown on the right). Note that the motor and fan warranty are void if the motor is rotating in the incorrect direction. Also verify that the motor speed control is functioning properly.



### SPEED CONTROL OPTIONS: OP MOTORS

#### Connections

This motor is designed to be connected to the three-phase supply mains at all times. Motor operation is controlled by an analog DC voltage signal. The motor is shipped with all necessary internal connections made for signal, power and ground connections. The three-phase AC lines are labeled “L1”, “L2” and “L3” and the earth ground line is a green and yellow wire. The customer is required to connect the three-phase AC lines and earth ground to their supply.

Figure 8. Connections for signal and power leads

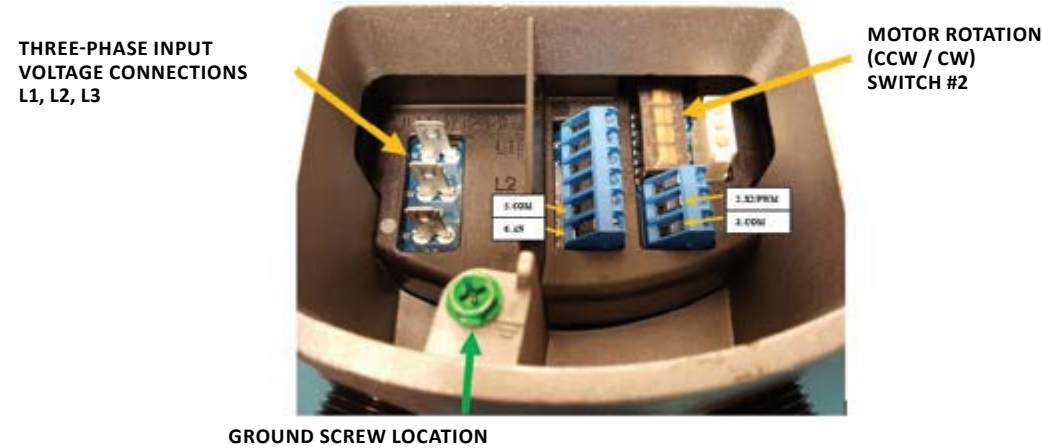

Figure 9. Connection label supplied on cover plate

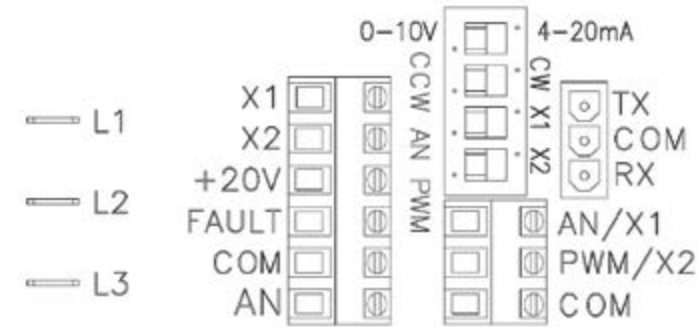

Table 3. Symax motors covered in this section

Motor Part Numbers	HP	Voltage/Phase
67003305	1	208 - 230/3
67003306	1½	208 - 230/3
67003307	2	208 - 230/3
67003309	3	208 - 230/3
67003405	1	460/3
67003406	1½	460/3
67003407	2	460/3
67003409	3	460/3

#### Operation Method

This engineering sample is setup for constant speed operation. The analog DC control voltage controls the target speed to maintain. Speed maximum setting (10V) has been set for 1750 RPM. Speed minimum setting has been set for 200 RPM with a turn on speed of 250 RPM at ~1.6V. The torque to speed relationship is dependent on the load on the motor.

#### Control Method

The default motor control method is 0-10V DC where 0V is off and 10V is full speed. DC signal should be applied per Figure 8. +V DC line attached where shown (AN). DC common line should be attached per Figure 9 where shown (COM).

### MAINTENANCE

These motors use brushless technology with sealed bearings so no maintenance is required other than keeping the motors dry and free of dirt, dust and debris. Always keep records of the maintenance that is performed.

### TROUBLESHOOTING

#### Remote Dial does not vary the motor speed (all motor types, except OP)

- Verify that correct connections are made (refer to pages 5-6).
- Make sure that the connections are solid.
- Check control input voltage at connection (inside transformer box).
- Make sure that the dial on the motor is opened CW.

#### Speed control does not vary the motor speed

- Check voltage to ensure the motor is receiving the correct input voltage.
- Check voltage at the remote dial. 12V AC should be present across the 12V and COM terminals and 0-10V DC should be present between the 0-10V and COM terminals.
- Verify that the potentiometer or 0-10V DC lead is properly wired to the control board according to the diagram.
- Verify that all of the connections inside of the fan and motor are secure.

#### GridPoint Controller does not connect to motor

- Check that cable connections are secure between the motor and the GridPoint controller.

#### Motor does not operate (TEFC motors: 67002107, 67002205)

- Check that the motor is wired for the correct supply voltage.
- Verify the Status LED is solid red.
- Verify that the jumper wire is present between terminals 9 and 10 on the low voltage terminal board because this is required for the motor to operate.
- Verify that the yellow wires are present on terminals 5 and 6 on the low voltage terminal board.

#### Fault indication (TEFC motors: 67002107, 67002205)

A red LED is located either on the control board or on the side of the conduit box to provide diagnostic assistance of motor faults. When a fault occurs, the LED will blink a specific number of times to identify the fault that has occurred. See the table to the right for fault indications.

When a fault occurs, the LED will blink the number of times corresponding to the fault, pause and then repeat blinking. Count the number of blinks multiple times to ensure that the proper fault has been identified. With most of the faults, the motor will restart automatically. If the motor experiences an overload fault over 10 times within an hour, the motor will shut down to protect itself and the power will need to be reset.

TEFC Motors (67002107 and 67002205)	
No. of Blinks	Indicated Fault
2	Overcurrent
3	Overvoltage
4	Undervoltage
5	Communication Error
6	Sync Loss
7	Spin Fault
8	3 Sec/60 Sec Motor Overload
9	Motor Over-Temperature



[WWW.AEROVENT.COM](http://WWW.AEROVENT.COM)

5959 TRENTON LANE N | MINNEAPOLIS, MN 55442 | PHONE: 763-551-7500 | FAX: 763-551-7501

© 2017-2023 TWIN CITY FAN COMPANIES, LTD.