

## TUBEAXIAL FANS ADJUSTABLE PITCH AIRFOIL DESIGN



Model ATA  
Direct Drive

**MODEL: ATA**



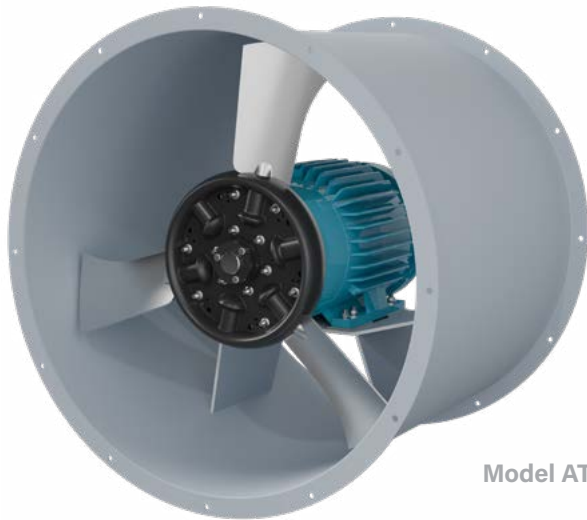

Model ATA

## Overview

### ATA

The Model ATA adjustable pitch tubeaxial fan is designed for clean air applications that permit the location of the motor in the airstream. The ATA features a unique blade design that maximizes energy transfer to the airstream with minimum noise. The blade pitch can be individually manually adjusted while the fan is stopped. This feature allows the user to balance the present system while affording the flexibility of further possible pitch adjustment in the future.

### Typical Applications Include

Data Center Exhaust, General HVAC, Generator Room Ventilation, Swimming Pool Exhaust, Kitchen Exhaust, Dishwasher Exhaust, Elevator Shaft Exhaust/Pressurization, Emergency Smoke Exhaust, Stairwell Pressurization

### Configurations

Direct Drive – vertical and horizontal mount configurations

### Impeller Type

Cast Aluminum

### Optional Construction

Clamshell Construction, Swingout Construction, Aluminum Housing, Hot Dip Galvanized Housing, 304SS Housing, 316SS Housing

### Certifications

AMCA Sound/Air and FEI

## Energy Regulations

Aerovent supports energy efficiency regulations enacted by the U.S. Department of Energy (DOE) and specific states. The selection and application of fan products is a significant part of these regulations. Engineers and specifiers must understand how to apply Aerovent products to their specific applications to meet applicable DOE and state regulatory requirements. Aerovent has made significant investments in product testing and development to provide efficient products. Developments in Aerovent's Fan Selector software are in place to aid your decision in product selection to assist with meeting the efficiency requirements as stipulated in the applicable regulations.



Aerovent, a Twin City Fan Company, certifies that the Model ATA shown herein are licensed to bear the AMCA Seal. Certified performance data may be found in Aerovent's Fan Selector software.



Scan the QR code to search Aerovent's AMCA-certified products.



For complete product performance, drawings and available accessories, download our Fan Selector software at [aerovent.com](http://aerovent.com).

## Overview

**ATA**

Standard fan/motor configuration is suitable for maximum air temperature of 104°F. Special motors are available for higher temperature applications. Please consult the factory for assistance.

### Model ATA

#### Arrangement 4 - Direct Drive

#### Sizes

Available in ten sizes from 13.65" to 48.78" in diameter.

#### Performance

Airflow to 75,600 CFM

Static pressure to 4.5" w.g.

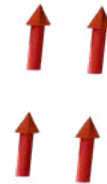

Paper Mill Application

## Design Innovation

The Model ATA fan blades have an ever-increasing airfoil chord length from the blade root to the blade tip. The additional chord length is placed at the leading edge rather than the trailing edge of the blade so that when set at an angle, the widest part of the airfoil is at maximum rotational speed in close proximity to the fan casing. This very wide blade tip area allows the Model ATA to maximize energy transfer to the airstream and minimize noise generation.

The blade pitch can be individually manually adjusted while the fan is stopped. This feature allows the user to balance the present system while affording the flexibility of further possible pitch adjustment in the future.

## Impeller Construction

The blades are made of permanent mold aluminum alloy castings for high strength and precision. Retaining bolts hold the root of the blade casting in position in a spherical pocket between two stamped carbon steel hub plates. The hub center boss is made of cast iron and is straight bored and keyed for direct attachment to motor or fan shafts or, in fans of 24" diameter and larger, is fitted with a taperlock bushing.



## Housing

Model ATA housings are made of continuously-welded, heavy-gauge carbon steel with integrally rolled inlet and outlet flanges. Integral flanges are provided with bolt holes for bolting to fan accessories or ductwork. Housings can be supported by bolting the integral flanges directly to ductwork or can be provided with bolted support legs or welded clips for mounting in a horizontal or vertical position.

When motor bearings require regreasing, extended grease fittings and grease leads are standardly furnished to permit relubrication of the motor bearings at the exterior of the fan housing. Motor leads are extended through liquid-tight conduit to the exterior of the fan housing to facilitate wiring.

Standard NEMA foot-mounted motors, of open drip-proof, totally enclosed or explosion-proof design are used on direct drive fans. Motors are squirrel cage induction, single speed, single winding, variable torque type for continuous-duty operation.

**AEROVENT**   
INDUSTRIAL VENTILATION SYSTEMS

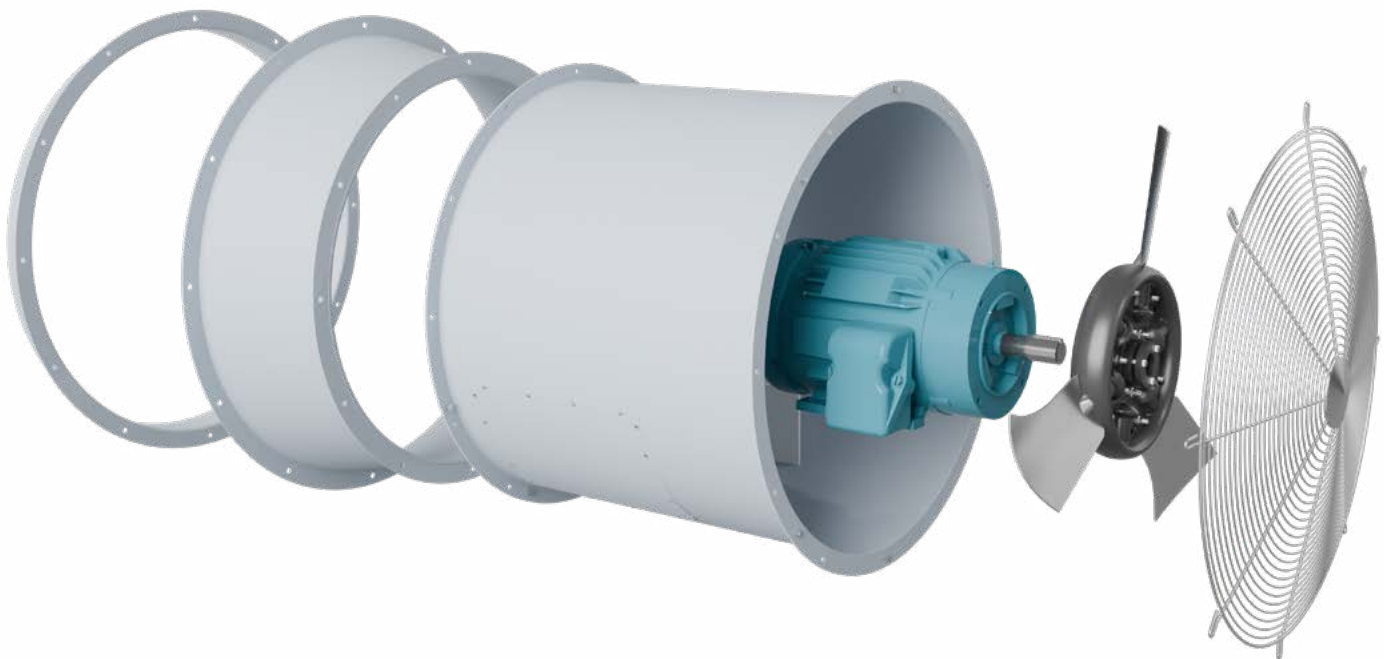



## Swingout Construction

Swingout construction provides easy access to the fan for cleaning and general maintenance without removing it from the ductwork. When quickopen clamp latches are released, the door swings out on heavy-duty hinges to provide out of the airstream access to the impeller for cleaning. For additional access to the shaft and bearings, a split inner cylinder is provided. Available in sizes 063-125.



Swingout Construction

## Clamshell Construction

Clamshell construction is ideal for applications needing regular cleaning. Depending on the size, one door (sizes 035-090) or two doors (sizes 100-125) are secured with quick access latches. These doors open outward and allow access to the internal components of the fan. It is essential to follow proper safety precautions during cleaning. If bearing, shaft or impeller replacement is required, the fan should be removed from the ductwork or roof to facilitate safe replacement of parts. If replacement of these parts while ducted or on the roof is required, it is recommended to use swingout construction.

## Corrosion Resistant Construction

For handling corrosive fumes, etc. Fan casings can be constructed of hot dipped galvanized steel, stainless steel, aluminum or protected with a wide variety of suitable protective coatings.



Clamshell Construction

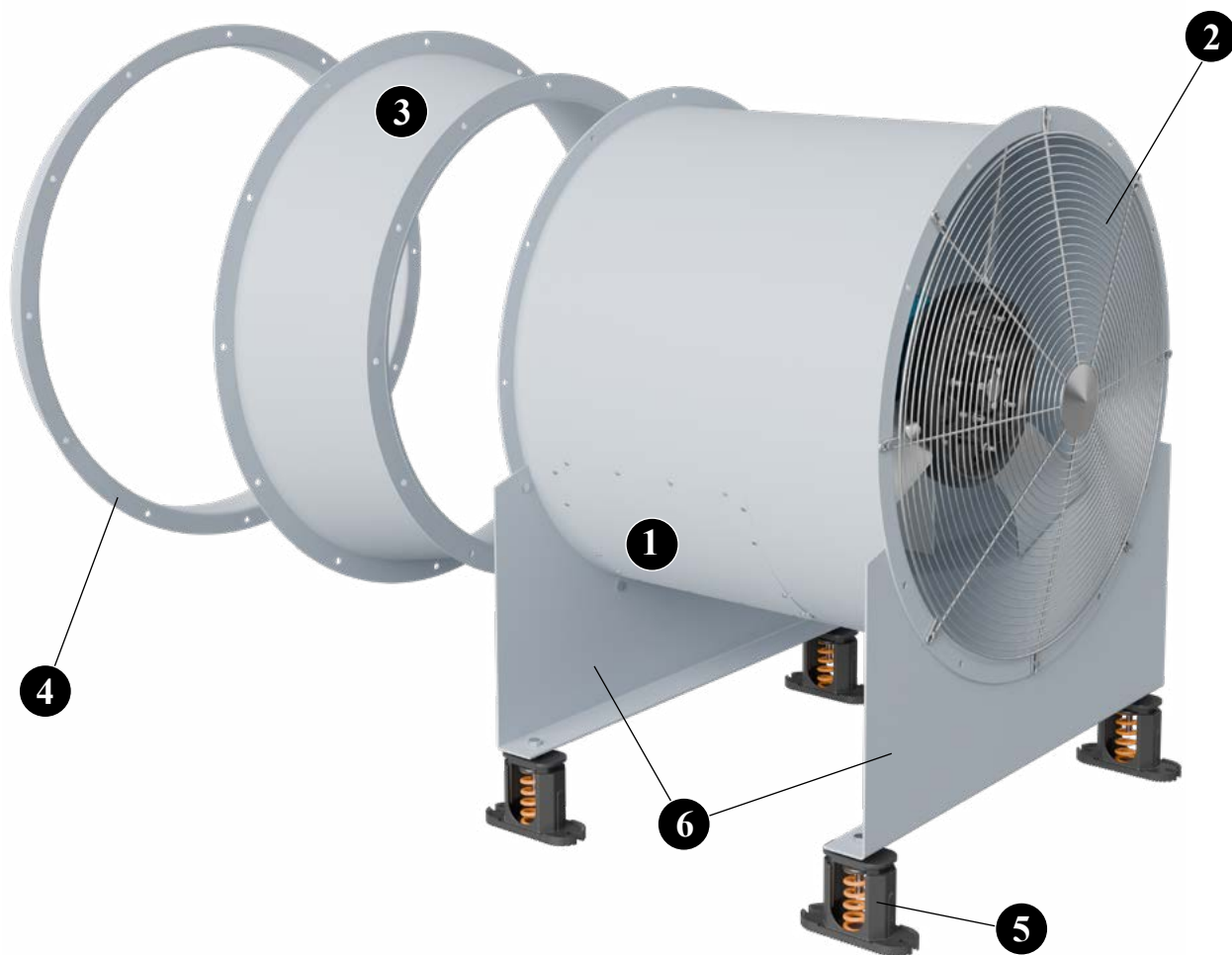

**1 Access Door** For quick impeller inspection and maintenance. Access doors are specified where examination and cleaning of the fan interior is required.

**2 Safety Screens** Available for mounting in the fan inlet or outlet in non-ducted applications.

**3 Inlet Cone** Heavy-gauge and spun to match the impeller intake rim to insure smooth airflow. Inlet cone flange is prepunched for mounting. Inlet cones are shipped loose as standard.

**4 Companion Flange** Companion flanges are commonly connected to a user's duct for easy installation of flexible connections between the fan and duct. Companion flanges and flex connectors are punched to match the fan's inlet or outlet punching.

**5 Vibration Isolators** Spring type vibration isolation mounts are available to dampen vibration and noise transmission in floor mounted installations. Also available in rubber-in-shear type construction.

**6 Support Legs, Horizontal** For horizontal flow with floor mounting, support legs are welded to the fan flange with bolt holes aligned for connection of ductwork.

## Other Accessories Include:

- Inlet Bell
- Vibration Isolators (Ceiling Hung)
- Shaft Seal
- Support Legs (Brackets)
- Outlet Cone
- Suspension Clips Horizontal Ceiling Hung

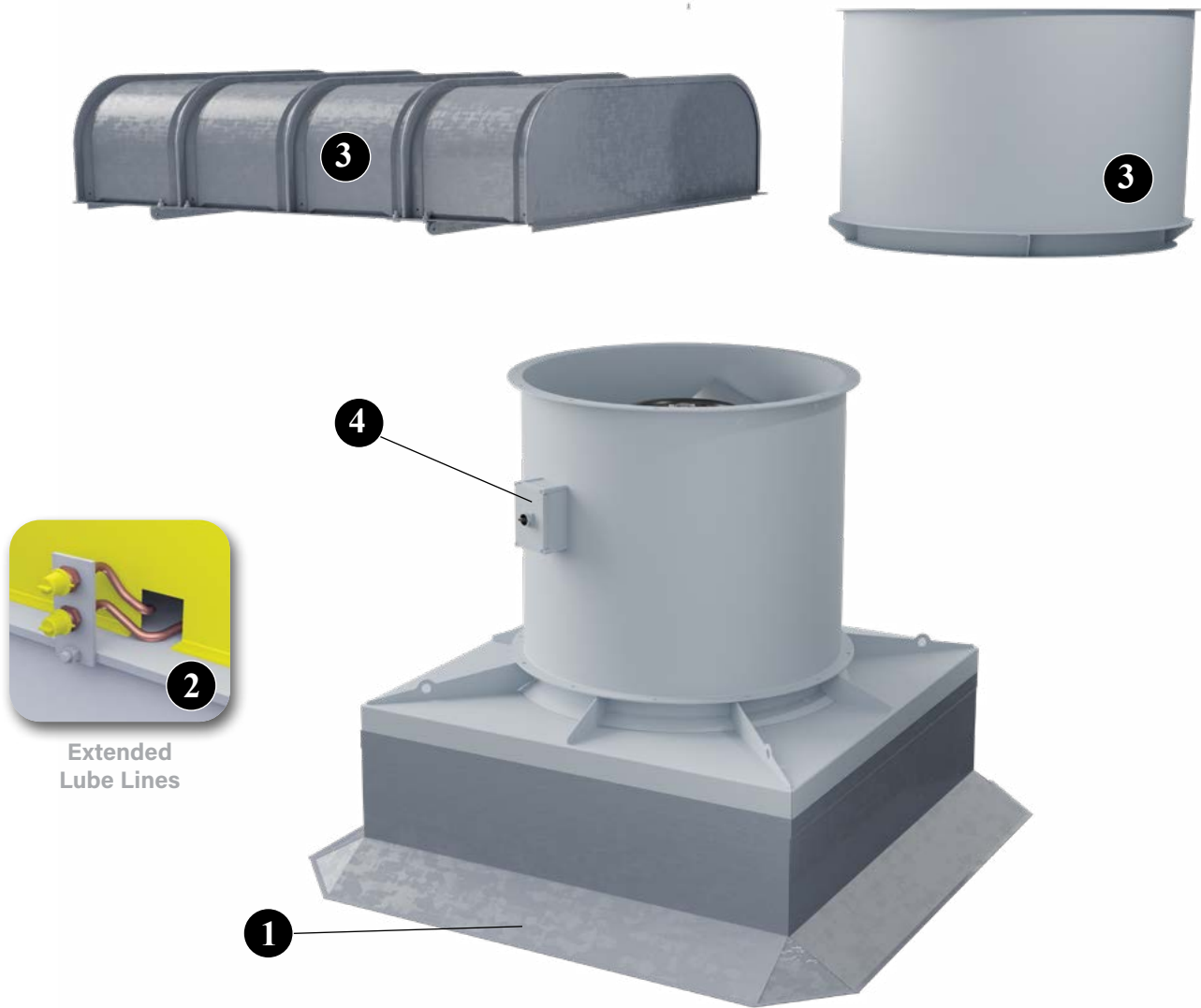

- 1 Canted Roof Curb** Prefabricated roof curbs are available in heavy-duty galvanized steel or aluminum construction, in heights of 8", 12" or 18". The canted curb is provided with a factory installed wood nailer. Curbs are provided with 1.5" of insulation as standard and feature continuously-welded seams for added rigidity and moisture protection. Prefabricated curbs are also available in raised cant, pitched and peak models. Refer to Catalog PRC-110 for complete details on roof curb options. Minimum 12" high curbs are recommended for use with motorized dampers.
- 2 Extended Lube Lines** When the motor requires re-greasing, lube lines with grease fittings are extended to the outside of the fan housing. Typically for frame sizes 280TS or 320T and larger.
- 3 Stack Cap & Hood** Stack caps are provided as a standard accessory on vertical roof mounted configurations. Stack caps feature butterfly type dampers that seal out weather when the fan is shut off. Filtered hood options available. Hoods are designed for either exhaust or supply airflow and can be fitted with filters to remove particulate from the supply airstream.
- 4 NEMA 3R Disconnect Switch** Disconnect switches offer superior environmental protection. From waterproofing to hazardous environments, know that you and your equipment are safe. Positive electrical shutoff during fan cleaning or maintenance provides additional safety and peace of mind. For more information about disconnect switches, see page 10.

# Mounting Arrangements

## Horizontal Construction

**Horizontal Base Mounted (HBM)** — Support legs are provided at each end of the fan for floor mounting.

**Horizontal Ceiling Hung (HCH)** — For duct mounted fans, four suspension clips are welded to the fan casing to allow ceiling suspension using rod hangers.

**Horizontal (HOR)** — For mounting configurations where support legs and suspension clips are not required.

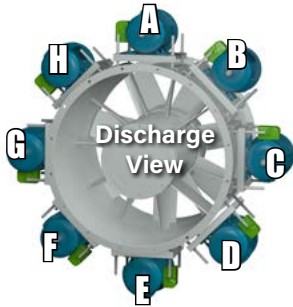

**HCH**  
Horizontal  
Ceiling Hung

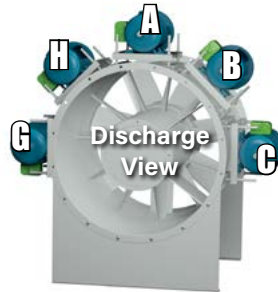

**HBM**  
Horizontal Base  
Mounted



**HOR**  
Horizontal  
Flange Mounted

## Vertical Construction

**Floor or Ceiling Mounted (VUI/VUO/VDI/VDO)** — Four vertical brackets are welded to either end of the fan housing. Bracket location is determined by airflow direction and support details (see below).

**Roof Mounted (VRM)** — A curb cap provides weathertight seal for roof curb mounted fans. A stack cap and weather cover are also available for the upblast style roof ventilator.

**Vertical (VUN/VDN)** — For mounting configurations where support brackets are not required.



**VUS**  
Vertical Upblast  
with Stack Cap



**VUH**  
Vertical Upblast  
with Hood and  
Curb Cap



**VDH**  
Vertical Downblast  
with Hood and  
Curb Cap



**VUI**  
Vertical Discharge Up,  
Floor Mount Support  
Brackets On Inlet



**VUO**  
Vertical Discharge Up,  
Ceiling Hung Support  
Brackets On Outlet



**VUN**  
Vertical Up  
No Brackets



**VDI**  
Vertical Discharge Down,  
Ceiling Hung Support  
Brackets On Inlet



**VDO**  
Vertical Discharge Down, Floor  
Mount Support  
Brackets On Outlet



**VDN**  
Vertical Down  
No Brackets



## Canted Roof Curbs

- Constructed of galvanized steel with continuously-welded seams
- Large 3" built-in 45° cant to accommodate roofing material to top of curb. Cant is beveled at corners for better support of roofing material
- Wood nailer (1½") secured to top ledge
- Lined with 1½" fiberglass fire-resistant, sound-absorbing insulation
- Damper shelf standard
- Options: Aluminum construction, burglar security bars, metal liner (galvanized or aluminum), special heights up to 24".



## Self-Flashing & Straight-Sided Roof Curbs

- Constructed of galvanized steel with continuously-welded seams
- Wide base plate (flashing) to ensure watertight seal to roof
- Top ledge covered with 3/16" polystyrene gasket (self-flashing) for weather seal and to reduce metal-to-metal conducted noise
- Wood nailer secured to top ledge (straight-sided)
- Lined with 1½" fiberglass fire-resistant, sound-absorbing insulation
- Damper shelf standard
- Straight-sided roof curbs are constructed with the same features as the self-flashing curbs, but are one dimensional to allow for field supplied cants and roofing material to be brought up to the top of the curb
- Options: Aluminum construction, burglar security bars, metal liner (galvanized or aluminum), special heights up to 24", single- or double-pitched curbs for sloping roofs



## Self-Flashing Vented Roof Curbs

### For High Temperature Applications

- Completely assembled unit, easier to install and less expensive than a field constructed curb
- Constructed of galvanized steel with continuously-welded seams and wide base flashing for watertight seal to roof
- Meets NFPA-96 code requirements
- Top ledge covered with 3/16" polystyrene gasket
- Furnished with ventilation slots



## Curb Adapters

- Constructed of galvanized steel with continuously-welded seams
- Top ledge covered with 3/16" polystyrene gasket to reduce metal-to-metal conducted noise and act as a weather seal
- Available in enlarger or reducer (shown) models





**NEMA 1**  
Disconnect Switch



**NEMA 3R**  
Disconnect Switch



**NEMA 4**  
Disconnect Switch

Disconnect switches provide positive electrical shutoff during fan cleaning or maintenance.

### **NEMA 1 Disconnect Switch**

A NEMA 1 disconnect switch is available shipped loose for field mounting and wiring or factory mounted and wired with ODP or TEFC motors.

### **NEMA 3R Disconnect Switch**

A NEMA 3R, rain proof, disconnect is available shipped loose for field mounting and wiring or factory mounted and wired externally.

### **NEMA 4 Disconnect Switch**

A NEMA 4, water and dust tight, disconnect is available shipped loose for field mounting and wiring or factory mounted and wired externally.

### **NEMA 7/9 Disconnect Switch**

A NEMA 7/9 disconnect switch is recommended on fans with explosion proof motors. The NEMA 7/9 switch is designed for use with fans operating in hazardous environments. Available shipped loose for field mounting and wiring. (Not shown.)



## Inlet Bell

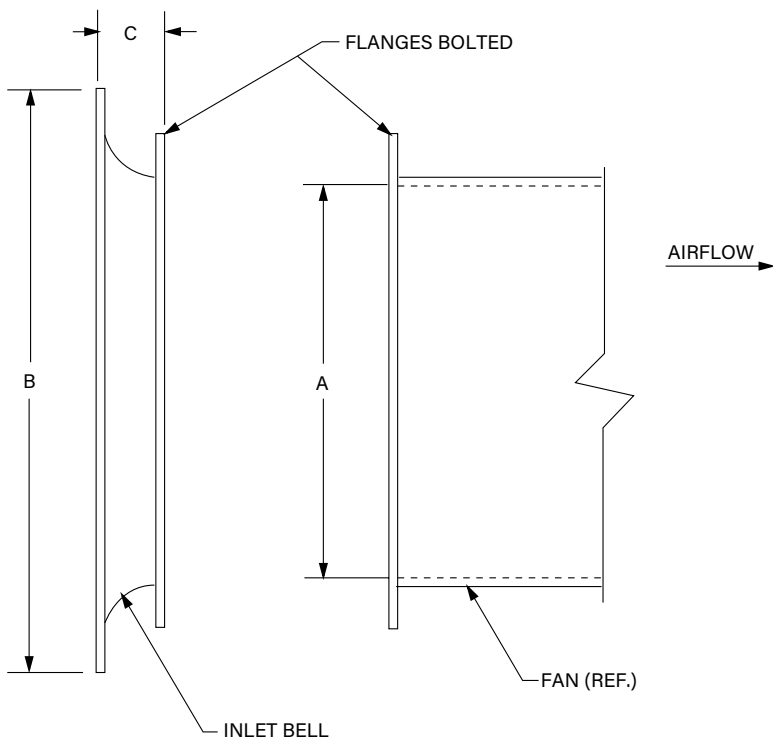

FAN SIZE	A	B	C	WT.
035	13.78	N/A	N/A	N/A
040	15.75	23.75	4.00	10
050	19.68	27.68	4.00	13
063	24.80	32.80	4.00	14
071	27.95	38.00	5.00	19
080	31.50	41.50	5.00	20
090	35.43	45.40	5.00	24
100	39.37	49.40	5.00	28
112	44.09	54.10	5.00	38
125	49.21	63.20	7.00	48

32254

## Inlet & Outlet Cone

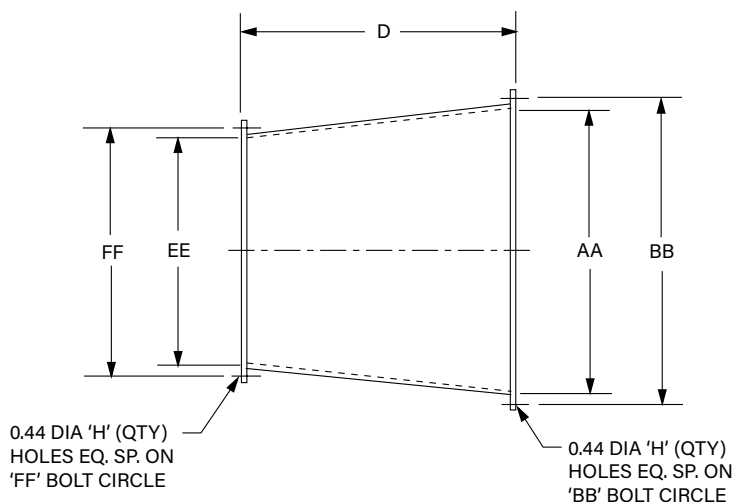

FAN SIZE	AA	BB	D	EE	FF	H	GA.	WT.
035	18.00	19.13	8.50	13.78	15.31	8	18	16
040	20.00	21.13	8.50	15.75	17.38	8	18	19
050	24.00	25.13	8.50	19.68	21.31	8	18	22
063	32.00	33.50	13.00	24.80	26.68	8	18	32
071	36.00	37.50	14.00	27.95	29.85	12	18	37
080	40.00	41.50	16.00	31.50	33.38	12	18	45
090	44.00	45.50	18.00	35.43	37.31	12	18	53
100	50.00	51.50	20.00	39.37	41.25	12	16	63
112	56.00	57.50	22.00	44.09	46.00	16	16	75
125	62.00	63.50	25.00	49.21	51.09	16	14	90

32253-B

## Model ATA, Arrangement 4 - Direct Drive

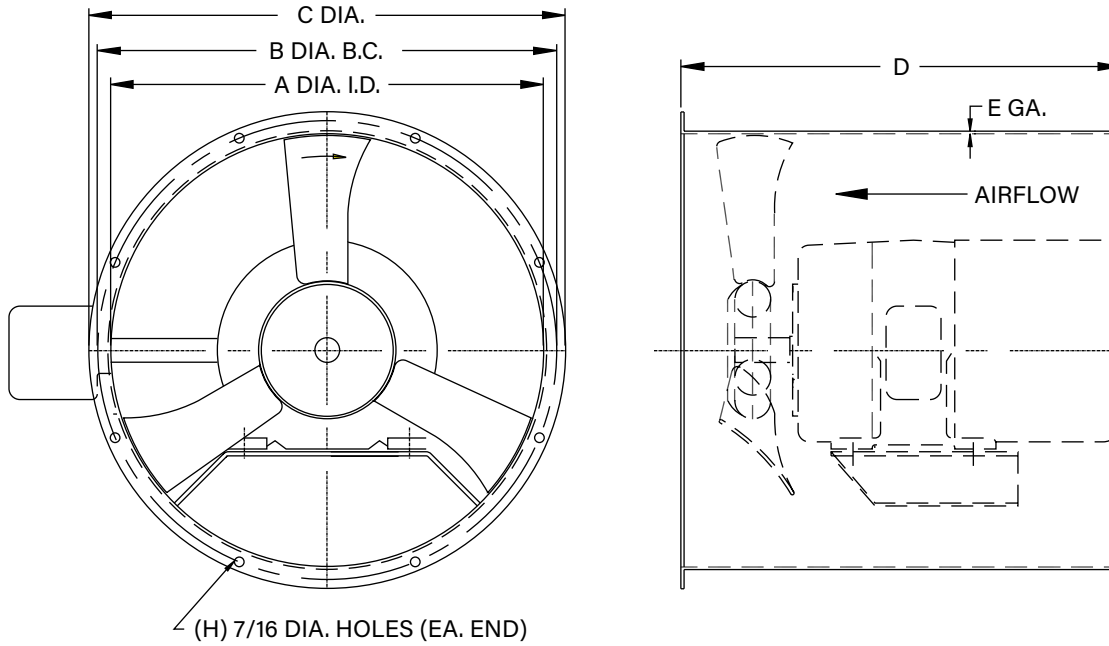

FAN SIZE	A	B	C	D	E (GA.)	G	MAX MOTOR FRAME	WEIGHT (LBS.)*
035	13 <sup>25</sup> / <sub>32</sub>	15 <sup>5</sup> / <sub>16</sub>	16 <sup>25</sup> / <sub>32</sub>	18	14	8	145T/U	25
040	15 <sup>3</sup> / <sub>4</sub>	17 <sup>3</sup> / <sub>8</sub>	18 <sup>3</sup> / <sub>4</sub>	18	12	8	145T/U	37
050	19 <sup>11</sup> / <sub>16</sub>	21 <sup>5</sup> / <sub>16</sub>	22 <sup>11</sup> / <sub>16</sub>	20	12	8	184T/U	51
063	24 <sup>13</sup> / <sub>16</sub>	26 <sup>11</sup> / <sub>16</sub>	28 <sup>5</sup> / <sub>16</sub>	24	10	8	215T/U	104
071	27 <sup>31</sup> / <sub>32</sub>	29 <sup>7</sup> / <sub>8</sub>	31 <sup>15</sup> / <sub>32</sub>	28	10	12	254T/U	127
080	31 <sup>1</sup> / <sub>2</sub>	33 <sup>3</sup> / <sub>8</sub>	34 <sup>1</sup> / <sub>2</sub>	28	7	12	254T/U	191
090	35 <sup>7</sup> / <sub>16</sub>	37 <sup>5</sup> / <sub>16</sub>	38 <sup>7</sup> / <sub>16</sub>	36	7	12	326T/U	275
100	39 <sup>3</sup> / <sub>8</sub>	41 <sup>1</sup> / <sub>4</sub>	42 <sup>3</sup> / <sub>8</sub>	36	7	12	326T/U	353
112	44 <sup>3</sup> / <sub>32</sub>	45 <sup>31</sup> / <sub>32</sub>	47 <sup>3</sup> / <sub>32</sub>	38	7	16	326T/U	394
125	49 <sup>7</sup> / <sub>32</sub>	51 <sup>3</sup> / <sub>32</sub>	52 <sup>7</sup> / <sub>32</sub>	40	7	16	365T/U	465

\*LESS MOTOR

31925-B





## Model

### ATA



Fans, where indicated on drawings and schedules, shall be Model ATA, Arrangement 4, direct drive, axial flow type with fan blades being capable of individual manual pitch adjustment while the fan is stopped. Fans shall be as manufactured by Aerovent, Minneapolis, Minnesota, and shall be of the size and capacity as indicated in the fan schedules.

**PERFORMANCE** — Model ATA fans shall be tested in an AMCA registered laboratory in accordance with AMCA 210 and AMCA 300 test codes and are licensed to bear the AMCA certified ratings seal for both air and sound, and fan energy index (FEI). In addition each unit shall be factory run tested and final trim balanced prior to shipment.

**CONSTRUCTION** — Fan casings shall be welded of low carbon, commercial quality hot rolled steel. Inlet and outlet flanges shall be integrally rolled mechanically from fan casing sheet steel to insure concentricity and alignment. Accuracy and uniformity of the fan casing shall be insured through the use of welding jigs and fixtures. A fabricated steel motor support base of minimum  $\frac{3}{16}$ " thick plate steel shall be welded into the inlet end of the fan casing.

**IMPELLERS** — Fan blades shall be permanent mold aluminum precision alloy castings. Fan center hub boss shall be cast iron bolted to stamped steel hub halves coated by electrodeposition. Blade tip clearance shall be within tolerance to meet certified performance. Fan blade pitch angle shall be individually manually adjustable when fan is stopped. The fan impeller shall be secured directly to the motor shaft with knurled cup point set screws in all sizes to 20" diameter and split taper lock bushings in all larger sizes. The motor and impeller assembly shall be enclosed entirely within the fan casing.

**BALANCING** — The fan impeller assembly shall be statically and dynamically balanced in accordance with ANSI/AMCA 204-96 "Balance Quality and Vibration Levels for Fans" to Fan Application Category BV-3, Balance Quality Grade G6.3. In addition, direct drive fan impellers shall be balanced on the motor shaft after final assembly in the fan casing, in the manufacturing facility to the following peak velocity values, filter-in, at the fan test speed:

Fan Application Category	Rigidly Mounted (In/Sec)	Flexibly Mounted (In/Sec)
BV-3	0.15	0.20

Final test room vibration levels in the axial, vertical and horizontal planes shall be recorded and a written copy shall be available upon request.

**MOTORS** — Fan motors shall be manufactured in accordance with current applicable standards of IEEE and NEMA. They shall be foot-mounted, NEMA standard, open drip-proof (ODP), continuous-duty, ball bearing with class "B" insulation. External grease fittings with extended grease leads shall be supplied for lubrication of the motor bearings on all motors that provide grease fittings. Motor bearings shall have a minimum L-10 life as defined by AFBMA of at least 40,000 hours (200,000 hours average life).

**FINISH** — The entire fan assembly, excluding the impeller and shaft, shall be properly washed and pretreated before application of a rust-preventative primer, if called out on the order. After the fan is completely assembled, a finish coat of paint shall be applied to the entire assembly, if called out on the order. The fan shaft shall be coated with a petroleum-based rust protectant.

---

**WALL MOUNTED FANS | TUBEAXIAL & VANEAXIAL FANS | CENTRIFUGAL FANS & BLOWERS**  
**ROOF VENTILATORS | AIR HEATERS & COOLERS | AIR MAKE-UP | FIBERGLASS FANS | CUSTOM FANS**

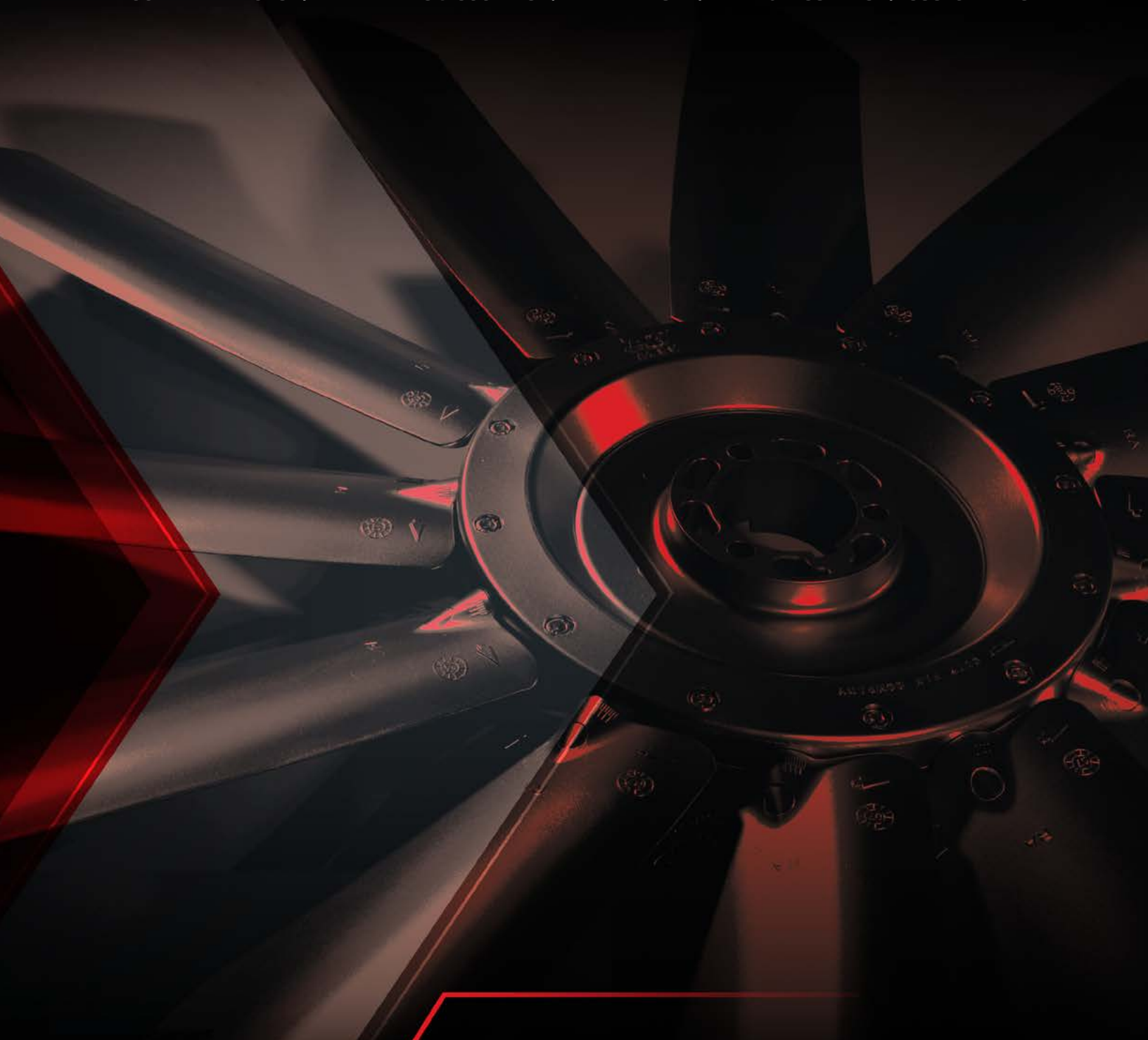

---

**AEROVENT**   
INDUSTRIAL VENTILATION SYSTEMS

**AEROVENT.COM**

---

**5959 Trenton Lane N. | Minneapolis, MN 55442 | Phone: 763-551-7500 | Fax: 763-551-7501**

©1999-2024 Aerovent, Minneapolis, MN. All rights reserved. Catalog illustrations cover the general appearance of Aerovent products at the time of publication and we reserve the right to make changes in design and construction at any time without notice.