

HOUSED CENTRIFUGAL HIGH PRESSURE FANS

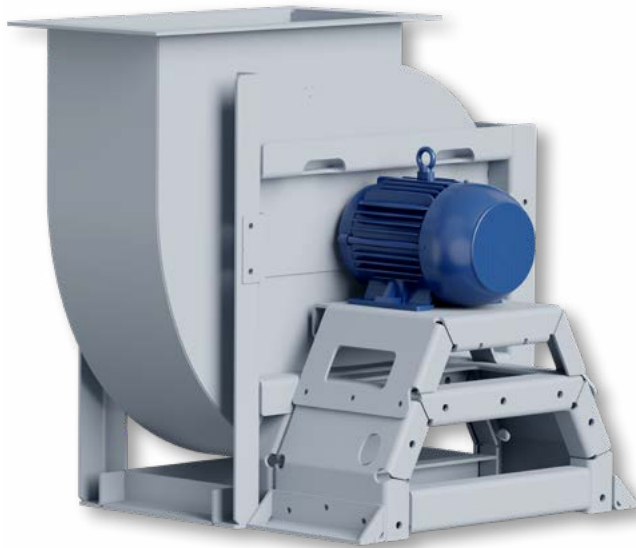

MODEL: CHF



Overview

CHF

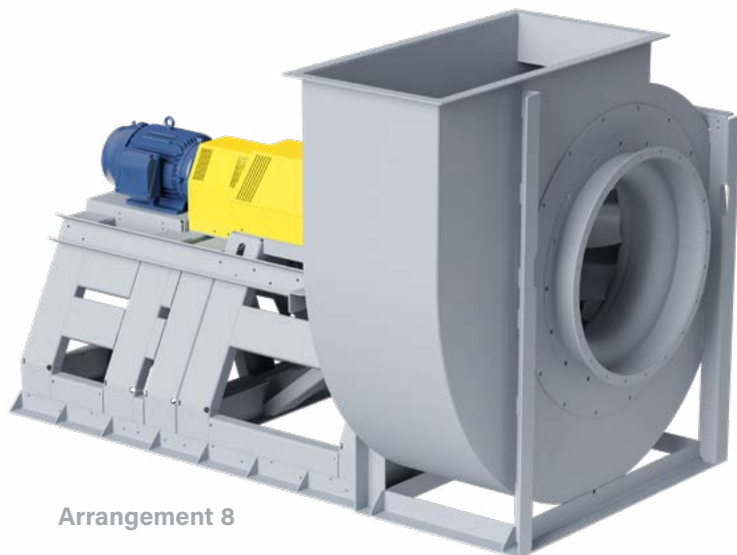

Arrangement 8

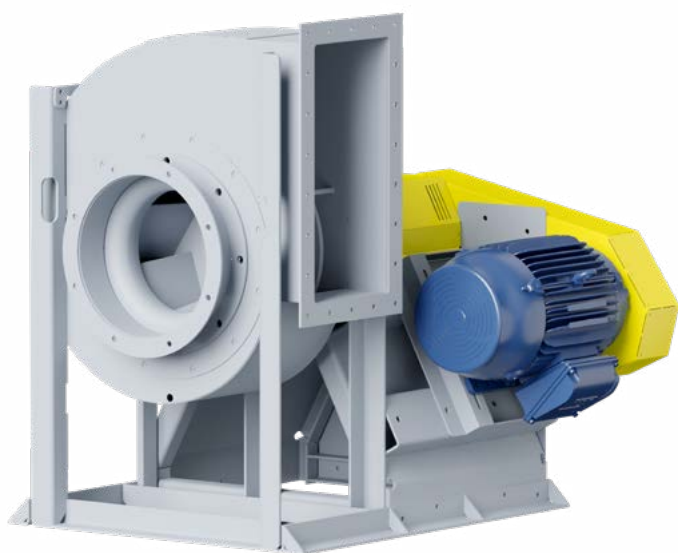

Arrangement 9

The Model CHF fan from Aerovent is a high efficiency backward curved industrial fan designed for handling relatively clean air in high pressure applications. The single-thickness, dihedral backward curved blade on the impeller is designed to move air in a highly efficient manner. The airfoil blade is even more efficient than the backward curved blade and should target applications where power needs to be optimized and noise minimized. Typical industries include general HVAC (exhaust, filtration, return and supply, air of commercial buildings), automotive, air pollution, fertilizer, metal and mineral processing, pulp and paper, petrochemical, pharmaceutical, power, water and wastewater treatment.

The aerodynamically designed impeller and housing of the Model CHF fan produces a high volume of air at a lower velocity, eliminating the need for an expansion easé.

Model CHF fans are available with a variety of construction options and accessories, offering the versatility and flexibility required in today's commercial and industrial applications.

Typical Applications Include

Agricultural, Air Pollution Control (including filtration and dust collection), Chemical/Corrosive Process, Combustion Air Drying Process Exhaust, Forced Draft on Fluid Bed Boilers, General HVAC, General Manufacturing, High Temperature Applications, Induced Draft After Baghouse and Other Process, Moisture Blow-Off, Product Cooling, Water Treatment

Impeller Types

Backward Curved and Airfoil

Configurations

Available in direct and belt driven Arrangements 1, 4, 8, 9 and 10

Optional Construction

High Temperature, Spark Resistant, X-Split Housings

Certification

AMCA Sound/Air, FEI



Aerovent certifies that the Model CHF shown herein is licensed to bear the AMCA Seal. Certified performance data may be found in Aerovent's Fan Selector software.



Scan the QR code to search Aerovent's AMCA-certified products.



For complete product performance, drawings and available accessories, download our Fan Selector software at aerovent.com.

Overview

CHF

Sizes and Performance

12" to 63" (305 mm to 1,600 mm)
impeller diameters
Airflow to 138,400 CFM (235,100 m³/hour)
Static pressure to 20.6" w.g. (5,120 Pa)
Airstream temperatures to 800°F

Construction

Available with AMCA Class I through III
Construction



Paint Booth Application with Model CHF



Energy Regulations

Aerovent supports energy efficiency regulations enacted by the U.S. Department of Energy (DOE) and specific states. The selection and application of fan products is a significant part of these regulations. Engineers and specifiers must understand how to apply Aerovent products to their specific applications to meet applicable DOE and state regulatory requirements. Aerovent has made significant investments in product testing and development to provide efficient products. Developments in Aerovent's Fan Selector software are in place to aid your decision in product selection to assist with meeting the efficiency requirements as stipulated in the applicable regulations.



Dust Collection Application with Model CHF

Housings

Heavy-gauge, reinforced, continuously-welded housings provide strength and durability for extended service life – a necessity in all commercial and industrial installations.

Inlet and outlet flanges are standard for duct connections. Housings are reinforced with rigid bracing to increase structural integrity. Lifting lugs are also standard on all fans. Precisely positioned cutoff plates and aerodynamically-engineered inlet cones provide high efficiency and smooth airflow through the fan.

Shaft

Shafts are AISI Grade 1040 or 1045 hot-rolled steel accurately turned, ground, polished and ring-gauged for accuracy. Shafts are generously sized for first critical speed of at least 1.43 times the maximum speed for the class.

Bearings

Bearings are heavy-duty, grease-lubricated, anti-friction ball or roller, self-aligning, pillow block type and are selected for minimum average bearing life (ABMA L-50) in excess of 200,000 hours at the maximum fan RPM.

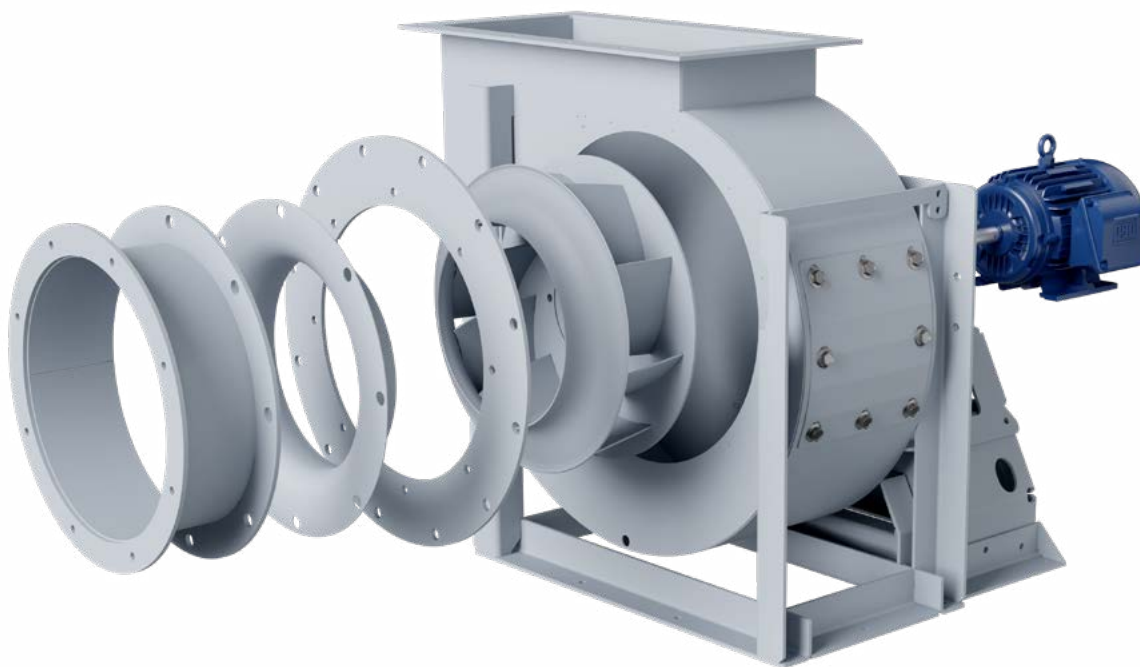

Impeller Design

The CHF impellers features heavy-gauge steel or aluminum construction and a non-overloading impeller design, suitable for applications requiring large volumes of air at moderate to high pressures.

The high efficiency impeller features backward curved or airfoil blades of single thickness, welded to the rim and back plate. The backward curved impeller is available in both clockwise and counter-clockwise rotations, whereas the airfoil impeller is offered in a counter-clockwise rotation only.

A conical shroud (rim) makes Model CHF fans less susceptible to the performance losses associated with poor inlet conditions.

All CHF impellers are statically and dynamically balanced to grade G6.3 per ANSI S2.19 for smooth operation prior to assembly of the fan, followed by a final balance of the entire rotating assembly.



Backward Curved



Airfoil

X-Split Housing

X-Split housing is a quartered-flanged housing that allows the removal of the impeller without disturbing the ductwork.

Spark Resistant Construction

Fan applications may involve the handling of potentially explosive or flammable particles, fumes or vapors. Such applications require careful consideration by the system designer to insure the safe handling of such gases. Aerovent offers the following classifications of spark resistant construction per AMCA Standard 99. It is the specifier's or the user's responsibility to specify the type of spark resistant construction with full recognition of the potential hazards and the degree of protection required.

- Type A: All parts of the fan in contact with the air or gas being handled shall be made of nonferrous material — usually aluminum and limited to 250°F.
- Type B: The fan shall have a nonferrous impeller or impeller and nonferrous rub ring about the opening through which the shaft passes — typically aluminum impeller and rub ring and limited to 250°F.
- Type C: The fan shall be constructed so that a shift of the impeller or impeller or shaft will not permit two ferrous parts of the fan to rub or strike.

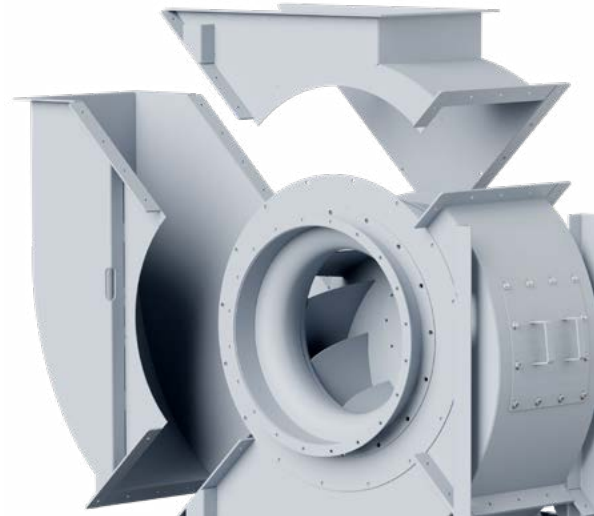

X-Split Housings

High Temperature Construction

Standard fan design options are available to handle airstream temperatures to 800°F. Consult your Aerovent sales representative for applications over 800°F or when aluminum (spark resistant) or stainless steel construction is required. The fan bearings should be kept outside of the hot airstream and below 130°F ambient. High temperature operating limits, available arrangements and necessary modifications are shown in Table 1.

Table 1. High Temperature Construction Requirements

TEMPERATURE (° F)	LUBRICATION	OTHER REQUIREMENTS	AVAILABLE ARRANGEMENTS
-22° to 300°	Grease	Standard Fan	1, 4*, 8, 9, 10**
301° to 500°	High Temp. Grease	Shaft Cooler, Shaft Seal, Expansion & Non-Expansion Bearings	1, 8, 9
501° to 800°	High Temp. Grease	Same as 301° to 500° With Addition of High Temp. Paint	1, 8
801° to 1000°	High Temp. Grease	Same as 501° to 800° With Addition of Stainless Airstream Components	1, 8

* Arrangement 4 limited to 180° F
 ** Arrangement 10 limited to 250° F

Nomenclature

CHF - 490 - BC - C

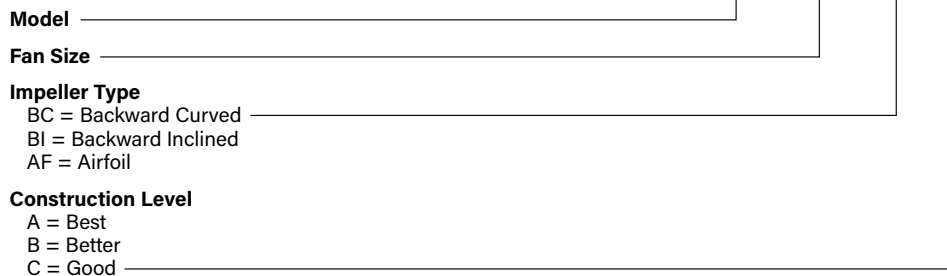

Arrangement 1

Arrangement 1 is typically belt driven. The impeller is overhung on the shaft, i.e., mounted at the end of the shaft. The motor can be mounted in any of the four AMCA standard motor positions shown on page 10. The two fan bearings are mounted on the bearing pedestal, out of the airstream, which makes them ideal for high temperature or contaminated air applications. Belt driven configurations offer performance flexibility.

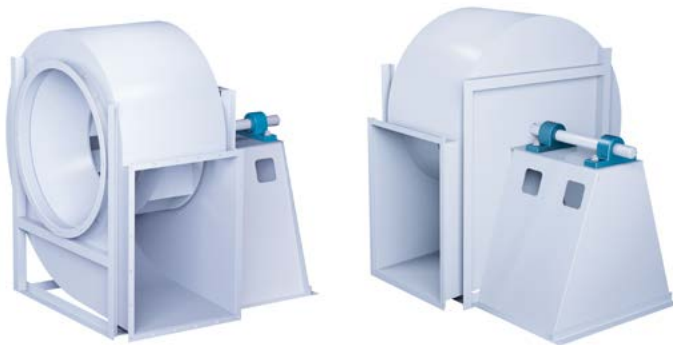

Arrangement 4

Arrangement 4 is a direct drive fan. The impeller is mounted directly to the motor shaft with the motor mounted to a pedestal. Arrangement 4 offers low maintenance since there are no fan bearings, fan shaft or drive parts to maintain. Arrangement 4 fans are typically limited up to size 365.



Arrangement 8

Arrangement 8 is a modified version of Arrangement 1 used for direct drive. The Arrangement 1 bearing pedestal is extended to accommodate the motor. A flexible coupling connects the fan and motor shaft.



Arrangement 9

Arrangement 9 is available as belt driven only. A motor slide base is mounted on the side of the bearing pedestal. This arrangement permits the unit to ship as a complete assembly with the motor and drive mounted. Typically, the motor is mounted on the left side of the pedestal for CW rotation fans and on the right side for CCW rotation fans.

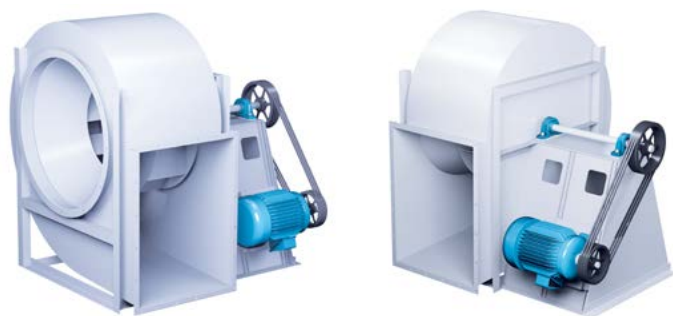

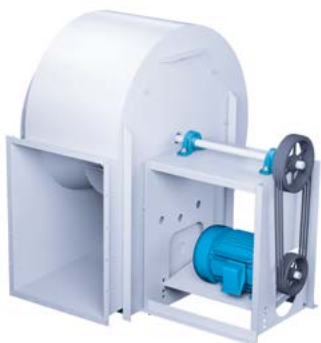

Sizes 122-365
(Vent Sets)



Sizes 402-600, Class I & II

Arrangement 10 SWSI – Single Width, Single Inlet

Arrangement 10 is available as belt driven only. For Class I and II fans, sizes 122 through 365, Arrangement 10 units are commonly referred to as Ventilating Sets. (Refer to Catalog 760 for more details.) Arrangement 10 units have adjustable motor bases mounted inside the bearing pedestal. This arrangement offers a more compact design than the Arrangement 9 and is suitable for roof or outdoor installations when supplied with the optional weather cover.

Inlet Boxes

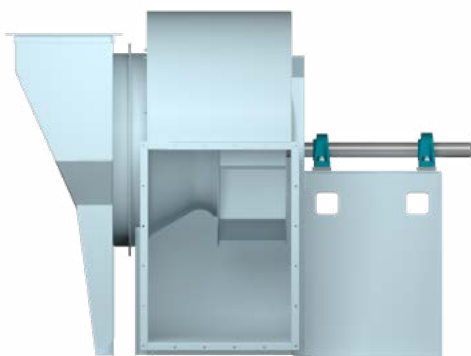

DETACHED INLET BOX
(BOLT ON)

Inlet Box Positions for Centrifugal Fans

INLET BOX POSITIONS AND DESCRIPTIONS	
45	Angular Down Intake
90	Horizontal Intake
135	Angular Up Intake
180	Bottom Up Intake
225	Angular Up Intake
270	Horizontal Intake
315	Angular Down Intake
360	Top Down Intake

Reference line is the Top Vertical Axis through center of fan shaft.

Position of inlet box and air entry to inlet box is determined from drive side of fan.

Position of inlet box is designated in degrees clockwise from Top Vertical Axis as shown.

Positions 135° to 225° may interfere with floor structures in some cases.

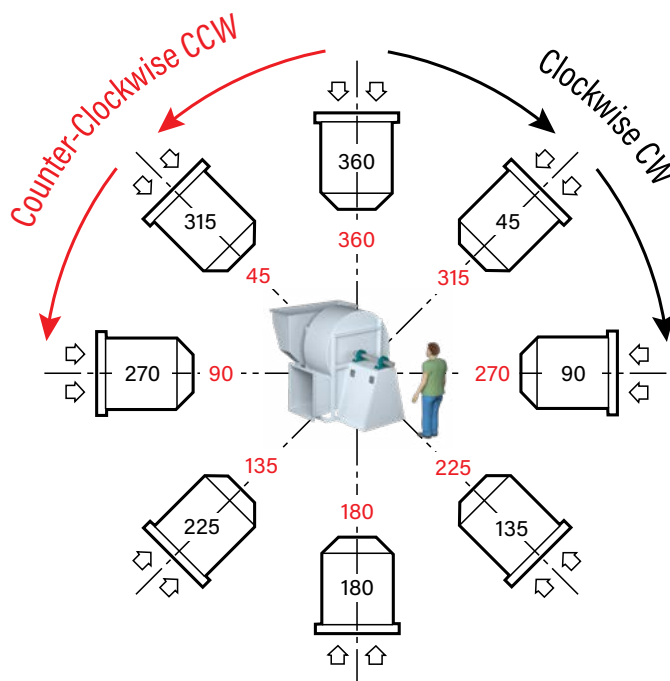

Inlet box positions **determined from Drive Side.**

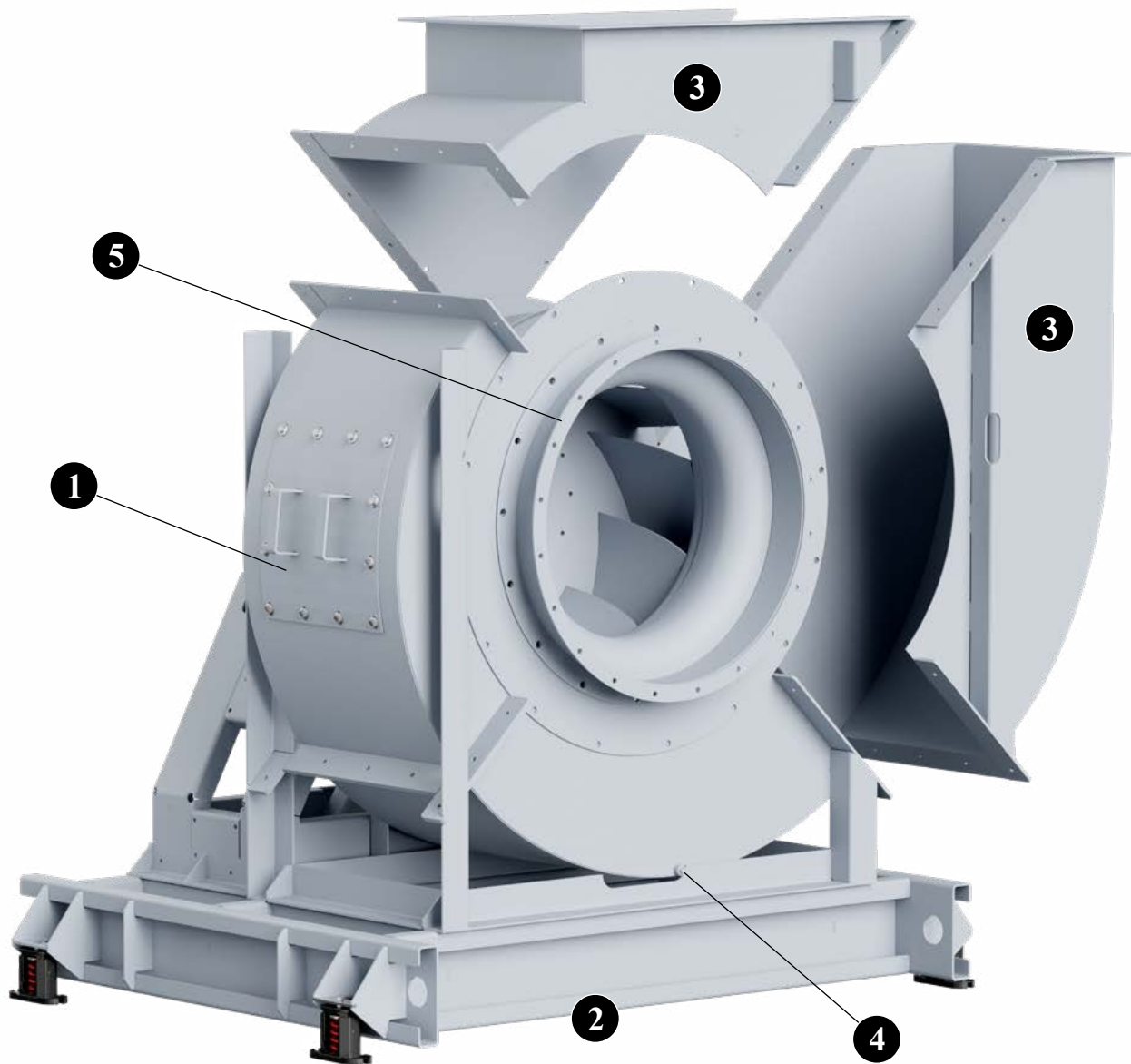

1 Bolted Access Door for impeller inspection and maintenance.

2 Isolation Base See description on page 11.

3 X-Split Housing All sizes are designed to permit impeller removal through the fan inlet. X-split housing is optional on sizes 300-402 and required on sizes 445 and larger. This style of flanged housing allows the impeller and shaft to be removed for either maintenance or replacement without disconnecting ductwork.

4 Drain w/ Plug Threaded pipe coupling welded to the lowest point in the housing scroll. All fans come with a weep hole in the bottom of the housing as standard.

5 Punched Flanged Inlet/Outlet Punched inlet flanges are available for duct mounting. Punched outlet flanges are welded to the fan outlet.

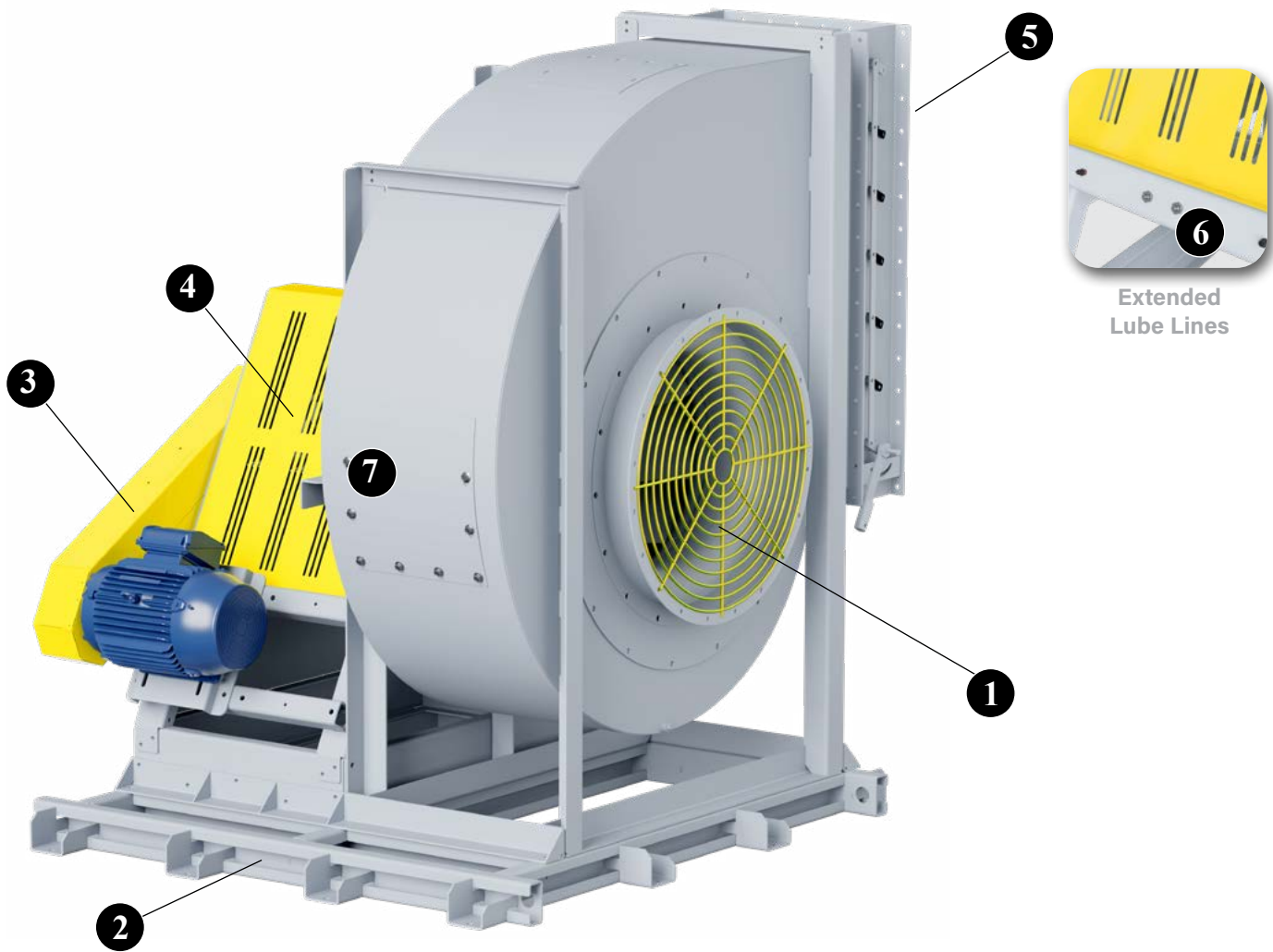

- 1 Inlet Safety Screens** Available for mounting in the fan inlet or outlet in non-ducted applications.
- 2 Unitary Base** See description on page 11.
- 3 Belt Guard** Belt guard protects personnel from the moving drive parts. OSHA and quick access guards are available.
- 4 Shaft & Bearing Guard** Sheet metal guard cover shaft and bearings. An exposed bearing shaft guard spanning the shaft between the bearings is available to provide open access to bearings for lubrication and vibration or temperature monitoring.
- 5 Outlet Dampers** Double surface airfoil blades are available in either parallel or opposed blade design.

- 6 Lube Lines** Allow for easy lubrication of bearings on belt driven units without disassembly by extending lubrication lines from fan bearings to exterior of pedestal.
- 7 Quick Access Door** For quick impeller inspection and maintenance. Access doors are specified where examination and cleaning of the fan interior is required.

Other Accessories Include:

- Piezometer Ring
- Bearing RTD (Temperature Sensors)
- Inlet Boxes
- Vibration Sensors
- Inertia Base
- Outlet Screen

Standard Configurations

CLOCKWISE (CW) - ROTATION & DISCHARGE (ROTATION VIEW FROM DRIVE SIDE)



COUNTER CLOCKWISE (CCW) - ROTATION & DISCHARGE (ROTATION VIEW FROM DRIVE SIDE)

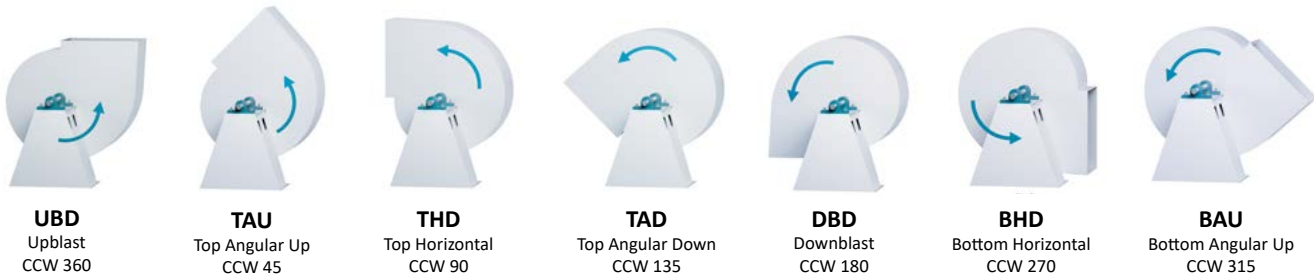

MOTOR POSITIONS

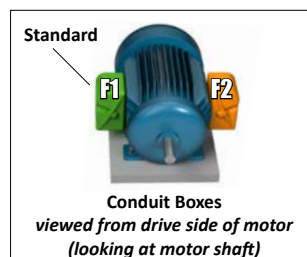
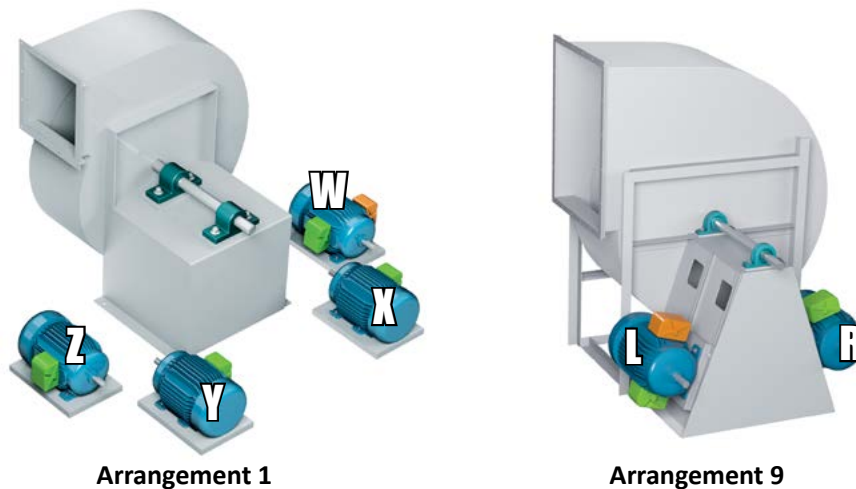

Unitary Bases

The structural steel base provides common support to fan, motor and drive including guards. This style of base is designed for use without isolators and requires adequate foundation integrity for proper operation.



Isolation Bases

Isolation bases provide a common support to fan, motor and drive, including guards. Constructed with heavy-duty structural channels and includes spring isolations. Not available on Arrangement 8. Flexible connectors at inlet and outlet are required.



Inertia Bases

Inertia bases provide a common support to fan, motor and drive including guards and utilize heavy-duty structural channel with spring isolators. Inertia bases incorporate reinforcing rods and require customer supplied concrete. Inertia bases are typically used on longer, direct drive fans to mitigate assembly deflection, maintaining proper alignment between the motor, coupling, shaft and bearings. Flexible connectors at inlet and outlet are required.



BC Impeller - Maximum RPM, Impeller Weights & WR²

FAN SIZE	CLASS I			CLASS II			CLASS III		
	MAX. RPM	WEIGHT (LB)	WR ² (LB-FT ²)	MAX. RPM	WEIGHT (LB)	WR ² (LB-FT ²)	MAX. RPM	WEIGHT (LB)	WR ² (LB-FT ²)
165	2820	33	7	3670	33	7	4000	41	9
182	2507	43	12	3262	43	12	4000	53	16
200	2256	54	18	2936	54	18	3712	67	24
222	2014	70	30	2621	70	30	3314	86	39
245	1790	90	49	2330	90	49	2946	111	64
270	1540	118	82	2030	118	82	2560	143	105
300	1367	151	138	1802	151	138	2272	187	178
330	1286	172	179	1696	172	179	2138	214	232
365	1215	194	229	1601	194	229	2020	242	298
402	1070	241	362	1405	241	362	1770	306	475
445	955	341	617	1254	341	617	1500	418	785
490	856	478	1036	1124	478	1036	1335	566	1277
542	764	676	1769	1004	676	1769	1264	773	2110
600	713	835	2450	937	835	2450	1180	935	2865
660	669	1018	3322	878	1018	3322	1106	1117	3813

Airfoil Impeller - Maximum RPM, Impeller Weights & WR²

FAN SIZE	CLASS I			CLASS II			CLASS III		
	MAX. RPM	WEIGHT (LB)	WR ² (LB-FT ²)	MAX. RPM	WEIGHT (LB)	WR ² (LB-FT ²)	MAX. RPM	WEIGHT (LB)	WR ² (LB-FT ²)
122	3420	7	1	4000	7	1	NA	NA	NA
135	3035	9	1	3913	9	1	NA	NA	NA
150	NA	NA	NA	NA	NA	NA	NA	NA	NA
165	2650	15	3	3450	15	3	4000	15	3
182	2356	19	5	3067	19	5	3695	19	5
200	2120	25	7	2760	25	7	3350	25	7
222	1893	39	14	2464	39	14	2970	39	14
245	1683	46	23	2190	46	23	2640	46	23
270	1470	60	45	1920	60	45	2340	60	45
300	1305	95	78	1704	95	78	2080	95	78
330	NA	NA	NA	NA	NA	NA	NA	NA	NA
365	1160	126	140	1515	126	140	1850	126	140
402	1085	164	194	1400	164	194	1665	164	194

BC Impeller - Bare Fan Weights (lb)

FAN SIZE	CLASS I					CLASS II					CLASS III				
	ARR. 1	ARR. 4	ARR. 8	ARR. 9	ARR. 10	ARR. 1	ARR. 4	ARR. 8	ARR. 9	ARR. 10	ARR. 1	ARR. 4	ARR. 8	ARR. 9	ARR. 10
165	362	360	560	414	671	362	360	560	414	671	362	360	560	414	671
182	443	448	654	821	832	443	448	654	821	832	443	448	654	821	832
200	539	515	758	881	887	539	515	758	881	887	539	515	758	881	887
222	721	662	1062	981	1023	721	662	1062	981	1023	721	662	1062	981	1023
245	873	778	1233	1122	1202	873	778	1233	1122	1202	873	778	1233	1122	1202
270	1020	929	1408	1424	1474	1020	929	1408	1424	1474	1020	929	1408	1424	1474
300	1326	1225	1799	1708	1719	1326	1225	1799	1708	1719	1326	1225	1799	1708	1719
330	1603	1398	2119	1864	1852	1603	1398	2119	1864	1852	1603	1398	2119	1864	1852
365	1715	1511	2239	2046	1955	1715	1511	2239	2046	1955	1715	1511	2239	2046	1955
402	1962	1746	2532	2379	—	1962	1746	2532	2379	—	1962	1746	2532	2379	—
445	2742	2513	3418	3181	—	2742	2513	3418	3181	—	2742	2513	3418	3181	—
490	3144	—	4016	—	—	3144	—	4016	—	—	3144	—	4016	—	—
542	4068	—	5034	—	—	4068	—	5034	—	—	4068	—	5034	—	—
600	4458	—	5504	—	—	4458	—	5504	—	—	4458	—	5504	—	—
660	4983	—	6131	—	—	4983	—	6131	—	—	4983	—	6131	—	—

Airfoil Impeller - Bare Fan Weights (lb)

FAN SIZE	CLASS I					CLASS II					CLASS III				
	ARR. 1	ARR. 4	ARR. 8	ARR. 9	ARR. 10	ARR. 1	ARR. 4	ARR. 8	ARR. 9	ARR. 10	ARR. 1	ARR. 4	ARR. 8	ARR. 9	ARR. 10
122	271	260	437	250	451	271	260	437	250	451	271	260	437	250	451
135	323	314	540	307	502	323	314	540	307	502	323	314	540	307	502
150	NA	NA	NA	NA	NA	NA	NA	NA	NA	NA	NA	NA	NA	NA	NA
165	362	360	560	414	671	362	360	560	414	671	362	360	560	414	671
182	443	448	654	821	832	443	448	654	821	832	443	448	654	821	832
200	539	515	758	881	887	539	515	758	881	887	539	515	758	881	887
222	721	662	1062	981	1023	721	662	1062	981	1023	721	662	1062	981	1023
245	873	778	1233	1122	1202	873	778	1233	1122	1202	873	778	1233	1122	1202
270	1020	929	1408	1424	1474	1020	929	1408	1424	1474	1020	929	1408	1424	1474
300	1326	1225	1799	1708	1719	1326	1225	1799	1708	1719	1326	1225	1799	1708	1719
330	NA	NA	NA	NA	NA	NA	NA	NA	NA	NA	NA	NA	NA	NA	NA
365	1715	1511	2239	2046	1955	1715	1511	2239	2046	1955	1715	1511	2239	2046	1955
402	1962	1746	2532	2379	NA	1962	1746	2532	2379	NA	1962	1746	2532	2379	NA





Model CHF

Fans shall be Model CHF Housed Centrifugal High Pressure/High Volume Fan utilizing either a backward curved or airfoil bladed impeller, as manufactured by Aerovent, Minneapolis, Minnesota.

PERFORMANCE — Performance ratings shall conform to AMCA Standard 208 (fan energy index), 211 (air performance) and 311 (sound performance). Fans shall be tested in accordance with ANSI/AMCA Standard 210 (air performance) and 300 (sound performance) in an AMCA-accredited laboratory. Fans shall be licensed to bear the AMCA certified ratings seal for sound, air and Fan Energy Index (FEI).

Fans shall have a sharply rising pressure characteristic extending through the operating range and continuing to rise beyond the peak efficiency to ensure quiet and stable operation. Fans shall have a non-overloading design with self-limiting horsepower characteristics and shall reach a peak in the normal selection area. All fans shall be capable of operating over the minimum pressure class limits as specified in AMCA Standard 99.

CONSTRUCTION — Fan housings and bearing pedestals shall be heavy-gauge, formed steel and welded construction. Housings shall be suitably braced to prevent vibration or pulsation. Discharge flanges shall be provided for rigidity and duct connection. Discharge flanges are punched as standard. All units are furnished with lifting lugs.

IMPELLER — Backward curved (BC) impellers shall be single thickness, designed for maximum efficiency and quiet operation. The CHF will also offer an airfoil (AF) type impeller of extruded aluminum designed for maximum efficiency and quiet operation. All impellers shall be statically and dynamically balanced.

SHAFT — Shafts shall be AISI 1045 hot rolled steel, accurately turned, ground, polished and ring-gauged for accuracy. Shafts shall be sized for the first critical speed of at least 1.43 times the maximum speed.

BEARINGS — Bearings shall be heavy-duty, grease lubricated, anti-friction ball or roller, self-aligning, pillow block type and selected for a minimum average bearing life (ABMA L-50) in excess of 200,000 hours at the maximum fan RPM.

DRIVE — Motor sheaves shall be cast iron, variable pitch on applications 20 HP and smaller, and fixed pitch on 25 HP and larger. Drives and belts shall be located external to the fan casing and rated for 150% of the required motor HP.

FINISH AND COATING — The entire fan assembly, excluding the shaft, shall be thoroughly degreased and deburred before application of a rust-preventative primer. After the fan is completely assembled, a finish coat of paint shall be applied to the entire assembly. The fan shaft shall be coated with a petroleum-based rust protectant. Aluminum components shall be unpainted.

ACCESSORIES — When specified, accessories such as access doors, drains, inlet and outlet flanges, belt guards, shaft and bearing guards, outlet screens, outlet dampers, spark resistant construction, split housings, high temperature construction, shaft seals, inlet boxes and shaft coolers shall be provided by Aerovent to maintain one-source responsibility.

FACTORY RUN TEST — All fans prior to shipment shall be completely assembled and test run as a unit at the specified operating speed or maximum RPM allowed for the particular construction type. Each impeller shall be statically and dynamically balanced in accordance with ANSI/AMCA 204-96 "Balance Quality and Vibration Levels for Fans" to Fan Application Category BV-3, Balance Quality Grade G6.3. Balance readings shall be taken by electronic type equipment in the axial, vertical and horizontal directions on each of the bearings. Records shall be maintained and a written copy shall be available upon request.





WALL MOUNTED FANS | TUBEAXIAL & VANEAXIAL FANS | CENTRIFUGAL FANS & BLOWERS
ROOF VENTILATORS | AIR HEATERS & COOLERS | AIR MAKE-UP | FIBERGLASS FANS | CUSTOM FANS

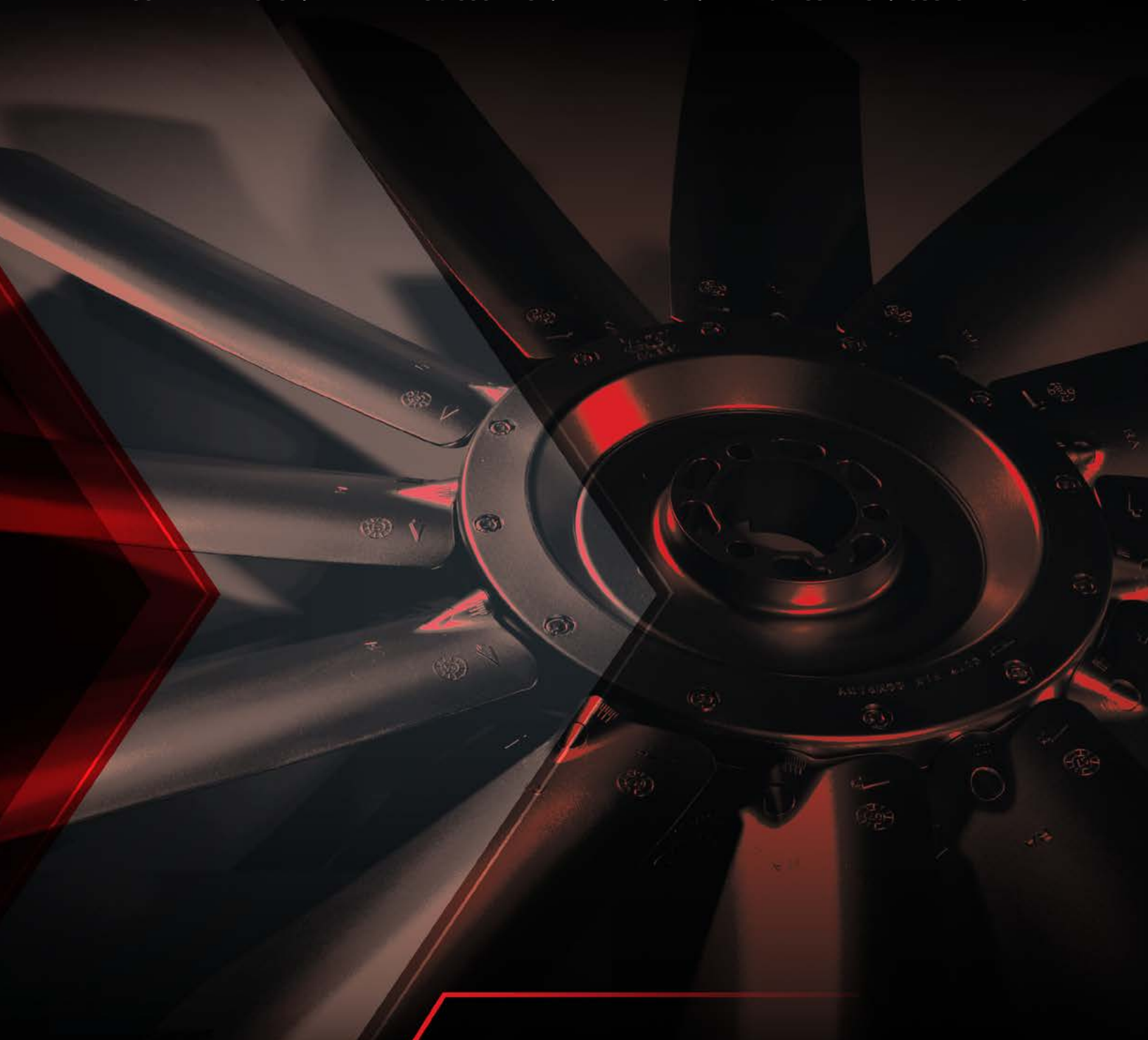

AEROVENT 
INDUSTRIAL VENTILATION SYSTEMS

AEROVENT.COM

5959 Trenton Lane N. | Minneapolis, MN 55442 | Phone: 763-551-7500 | Fax: 763-551-7501

©2026 Aerovent, Minneapolis, MN. All rights reserved. Catalog illustrations cover the general appearance of Aerovent products at the time of publication and we reserve the right to make changes in design and construction at any time without notice.